

THE SCHWERTFEGER LIBRARY
1225 W. Dayton Street
Madison, WI 53706

THE UNIVERSITY OF CHICAGO

THE HEAT BUDGET OVER A CORNFIELD

A DISSERTATION SUBMITTED TO
THE FACULTY OF THE DIVISION OF THE PHYSICAL SCIENCES
IN CANDIDACY FOR THE DEGREE OF
DOCTOR OF PHILOSOPHY
DEPARTMENT OF METEOROLOGY

BY
V. E. SUOMI

CHICAGO, ILLINOIS

JUNE, 1953

THE UNIVERSITY OF CHICAGO

DATE May 29, 19 53

Suomi, Verner Edward Author December 6, 1915 Birth Date

The Heat Budget Over a Cornfield Title of Dissertation

Meteorology Department or School Ph. D. Degree June, 1953 Convocation

Permission is herewith granted to the University of Chicago to make copies of the above title, at its discretion, upon the request of individuals or institutions and at their expense.

7 1990
6/30/53
Date filmed

51
Number of pages

Verner E. Suomi
Signature of author

Extensive Quotation or Further Reproduction of This Material by Persons or Agencies Other than the University of Chicago May Not Be Made without the Express Permission of the Author.

SHORT TITLE: _____

IRREGULAR NUMBERING

OVERSIZED SHEETS

PAID { By cash
By thesis deposit

DATE BILLED _____

ACKNOWLEDGEMENTS

The author is pleased to acknowledge the aid of his associates, Dr. Matti Franssila of Helsinki, Dr. Reid A. Bryson, and Mr. Norman Islitzer for their many contributions to this experiment. Acknowledgement is due also to Dr. C-G. Rossby and Dr. H.R. Byers for their continued interest and support in the years since the author first heard them as a student. Finally, thanks are expressed to the Cambridge Research Center for their financial aid.

CHAPTER I

INTRODUCTION

The kinetic energy of the atmosphere is derived from solar energy and is ultimately dissipated via turbulence and viscosity as friction. A major fraction of these energy transformation occur at the earth's surface with the atmosphere and the surface acting together as a heat engine whose working substance is air containing water vapor. Ever since W. Schmidt¹ introduced the "Austausch Theory" as a means of dealing with the problem of turbulent transfer of heat, moisture, momentum, and other air properties in the surface layer, a considerable amount of work has been done by others to develop the theory further and to apply it to practical problems in micrometeorology. Perhaps the most important problem to be answered by any turbulence theory, meteorologically speaking, is that of the heat budget of the lower atmosphere, that is, "What happens to the sunlight?" However, the heat flux turns out to be the most elusive part of the theory because the field of flow is strongly affected by the heat transfer process. Research in this field has proceeded along three main directions: (1) energy budget studies where each term comprising energy balance is measured independently

¹W. Schmidt, "Massenaustausch in freier Luft und Verwandte Erscheinungen," Prob. d. Kosm. Physik, Vol. VII (Hamburg: H. Grand, 1925).

or as nearly independently as possible; (2) mass, energy, and momentum transfer studies based on the mean profiles of wind, temperature, moisture, or other air properties in a manner analogous to, but not identical with, molecular transfer of these same air properties; and (3) intimate structure studies where fine scale fluctuations of air properties measured with rapid response sensing elements are multiplied by the instantaneous component of the wind, the flux being given by the time integral of the product. The measurements reported in this paper can be classified under item (1), the energy balance of the surface layer.

Most of the difficulty that arises when one attempts to apply normal aerodynamical methods for the solution of heat flux problems at the earth's surface is traceable to the effect of the variable density gradient.¹ We have, in a manner of speaking, a combination of mechanical and convective turbulence. In order to aid the study of turbulence in the boundary layer in the presence of a variable density gradient it is very helpful to have an independent measure of the sensible and latent heat flux. The purpose of this paper is to determine whether or not sufficiently precise values of these fluxes can be obtained from energy balance measurements.

In the energy balance method, the sensible and latent heat fluxes are obtained as a residue of a number of other measurements. Since this residue is the difference of several

¹O.G. Sutton, Compendium of Meteorology (Boston: American Meteorological Society, 1951), p. 507.

large numbers, each must be measured with good precision; therefore, in the sections which follow, considerable emphasis is given to estimates of error for each parameter measured.

CHAPTER II

DETERMINATION OF THE HEAT FLUX BY THE ENERGY BALANCE AT THE EARTH'S SURFACE

I. Notation

The following convention of symbols will be used in the main body of the text. All terms in the heat balance are expressed in equivalent energy flux through a unit surface. One (1) langley (Ly) = 1 gram calorie per square centimeter.

R_z = Net radiation at height z , positive away from the surface.

B_0 = True heat conduction into the soil, positive away from the surface.

L_z = Sensible heat flux at height z , positive away from the surface.

E_z = Latent heat flux at height z , positive away from the surface.

T_z = Temperature in degrees Centigrade at height z .

e_z = Vapor pressure in millibars at height z .

ρ = Air density.

ρ_w = Water vapor density.

J = Joule's constant.

A_h = Austausch coefficient for heat.

A_v = Austausch coefficient for water vapor.

β = Bowen Ratio.

t = Time.

z = Height in centimeters, positive upward.

τ = Period.

P = Pressure in millibars.

\mathcal{L} = Heat of vaporization.

C_p = Specific heat of air at constant pressure.

C = Specific heat of the soil per unit volume.

ϵ = Eddy dissipation per unit volume.

w = Vertical component of the wind.

u_z = Wind speed at height z .

II. Energy Balance at the Earth's Surface

Albrecht¹ has given the energy balance for a thin surface layer as

$$R_o + B_o + I_o + E_o = 0 . \quad (1)$$

Direct caloric measurements of R_o and B_o were taken by methods to be described presently. The remainder is separated into L_o and E_o by making use of the Bowen ratio.² The expression for the Bowen ratio given by Sverdrup is³

$$\beta = 0.64 P/1000 \frac{\partial T/\partial z}{\partial e/\partial z} \quad (2)$$

Equation (1) applies only to the vanishingly thin surface layer but in order to obtain the Bowen ratio it is necessary to measure

¹F. Albrecht, "Der gegenwartig Stand und der Warmhaushaltsforschung," Meteor. Zeitschrift, 60 (1943), p. 44.

²I.S. Bowen, "The Ratio of Heat Losses by Conduction and by Evaporation from any Water Surface," Physical Review, Ser. 2, 27 (1926), pp. 779-787.

³H.U. Sverdrup, Oceanography for Meteorologists (New York: Prentice Hall, 1942), p. 63.

temperature and vapor pressure gradients above the surface. Rider and Robinson¹ show that three correction terms are necessary for this procedure. The difference between E_0 and E_z is given by

$$E_z - E_0 = -L \int_0^z \frac{\partial e}{\partial t} dz \quad (3)$$

which is the rate latent heat is added to the layer. Similarly,

$$L_z - L_0 = -(R_z - R_0) - \int_0^z \rho C_p \frac{\partial T}{\partial t} dz + J \int_0^z \epsilon dz \quad (4)$$

is the rate sensible heat is added to the layer. The fourth term representing the eddy dissipation in the column has been added for the sake of completeness. The terms containing the time changes of e and T will usually be less than 1 per cent of L_0 . The radiation term cannot be measured readily because when the radiometer is close to the surface its own shadow will interfere with the measurement. Rider and Robinson² use a radiation chart to show that the sensible heat added by radiation is usually small but may be up to 10 per cent of L_0 .

The exact position of the surface for which equation (1) is written becomes somewhat obscure when the surface is covered with vegetation. Then B_0 also contains the heat stored in the vegetation. The correction, however, is small. It is only 1.0 per cent for 7-foot corn whose yield as green silage was seventeen tons per acre.

Implicit in the use of the Bowen ratio concept as the other

¹N.E. Rider and G.D. Robinson, "A Study of the Transfer of Heat and Water Vapor," *Quart. Jour. Roy. Met. C.*, 77 (1951).

²Ibid., p. 391.

equation relating L_0 and E_0 is the assumption that $A_h = A_v$. Also, we assume that there are no steady circulations, that is, $\bar{w} = 0$. Lettau¹ suggests that the Austausch coefficient has a dynamic and a thermal component. If the moisture and temperature fluctuations in the eddying air volumes are not highly correlated, the buoyant acceleration can act as a "Maxwell's Demon" to separate the air volumes' transport of sensible and latent heat, thus A_h will not equal A_v . An analysis of temperature and moisture fluctuation data given by Swinbank² and temperature refractive index data given by Gerhardt and Crain³ shows a high positive correlation between fluctuations of temperature and vapor pressure when the measurements are made 0.75 to 1.5 meters from the surface. The correlation is lower when the measurements are made 5.0 meters from the surface. Evidently, in the region near the surface, strong buoyant accelerations will not have had time to accumulate any significant velocity difference between air parcels carrying sensible heat and those transporting latent heat. Lettau⁴ has stated that buoyant accelerations near the surface have very

¹Heinz Lettau, "Isotropic and Non-isotropic Turbulence in the Atmospheric Surface Layer," Geophysical Res. Paper No. 1 (Cambridge: Air Force Cambridge Research Labs., Dec., 1949).

²W.C. Swinbank, "The Measurement of Vertical Transfer of Heat and Water Vapor by Eddies in the Atmosphere," Jour. Meteor., 8 (1951), p. 141, fig. 7.

³J.R. Gerhardt and C.M. Crain, "The Direct Measurement of the Variations in the Index of Refraction of Atmospheric Air at Microwave Frequencies," Elec. Eng. Res. Lab. Rpt. No. 38, (Austin: University of Texas, 1950), figs. 10-14.

⁴Heinz Lettau, "Theory of Surface Temperature and Heat Transfer Oscillations near a Level Ground Surface," Trans. Amer. Geophys. Union, 32 (1949), p. 190.

little effect on the intensity of mixing. This fact has been verified by Pasquill.¹ In the light of this evidence it is difficult to understand why A_h should not be very nearly equal to A_v in the surface layer. Yet, Pasquill's² direct measurements of the components of the heat budget show $A_v \neq A_h$. Could Pasquill's evaluation of L_0 have had a systematic error? Apparently Rider and Robinson³ think so, for they do not accept his measurements which show A_v and A_h to be unequal. If, then, we confine the measurements to heights near the surface A_h/A_v will be very nearly unity.

III. Observations

A. Site.--The measurements were taken on the University of Wisconsin Marsh Farm at Madison. This 120 acre field is exceptionally level, having height variations of only 20 to 40 cm. over most of its area. A particular feature of this location is its uniform soil characteristics both with respect to composition and moisture content. The water table is held at a constant level 40 to 50 cm. below the surface by means of a tile system and electric pump. The peat soil provides an ample supply of moisture from below through capillary action.⁴ The obstructions to the wind were a 100 foot high building one mile to the southwest, 40 foot trees three-fourths of a mile to the south, and 50 foot

¹F. Pasquill, "Eddy Diffusion of Water Vapor and Heat near the Ground," Proc. Roy. Soc., Ser. A, 198 (1949), p. 136.

²Ibid.

³Rider and Robinson, op. cit., p. 388.

⁴S.T. Lokken, "Capillary Drainage Effects" (Unpublished Master's Thesis, Civil Engineering, University of Wisconsin, June, 1950).

trees one-half mile to the west and northwest, one-fourth mile to the north, and 1000 feet to the east. A schematic diagram of the installation is shown in figure 1.

B. Net radiation, R_z .--The net short wave and long wave radiation was measured with a newly developed net radiation instrument. A complete description of this instrument, method of zero set, calibration, and accuracy has been given in a paper by Suomi, Franssila, and Isletzer.¹ The net radiation term measured with this instrument was accurate to about 2 per cent. This is indeed fortunate, since radiation is usually the largest term of the heat budget.

C. Soil storage, B_o .--The flow of heat into or out of the earth's surface is given by the product of the thermal conductivity and the temperature gradient in the boundary soil layers. This simple relationship is not usable because the thermal conductivity of the soil is not a constant. It depends on the soil composition, compaction, and moisture content. This is not the only difficulty. One is forced to obtain the temperature of a two-dimensional surface with a three-dimensional thermometer. Martinelli, et al.² and Deacon³ have described heat meters based

¹V.E. Suomi, M. Franssila, and N. Isletzer, "An Improved Net Radiation Instrument," Scientific Report No. 1, Contract AF 19(122)-461, Department of Meteorology, University of Wisconsin, April, 1953.

²R.C. Martinelli, E.H. Morrin, and L.M.K. Boelter, "An Investigation of Aircraft Heaters, V. Theory and Use of Heat Meters for the Measurement of Ratio of Heat Transfers which are Independent of Time," National Advisory Committee for Aeronautics Advance Research Report 4H09, August, 1944.

³E.L. Deacon, "The Measurement and Recording of the Heat Flux into the Soil," Quar. Jour. Roy. Met. S., 76 (1949), p. 479.

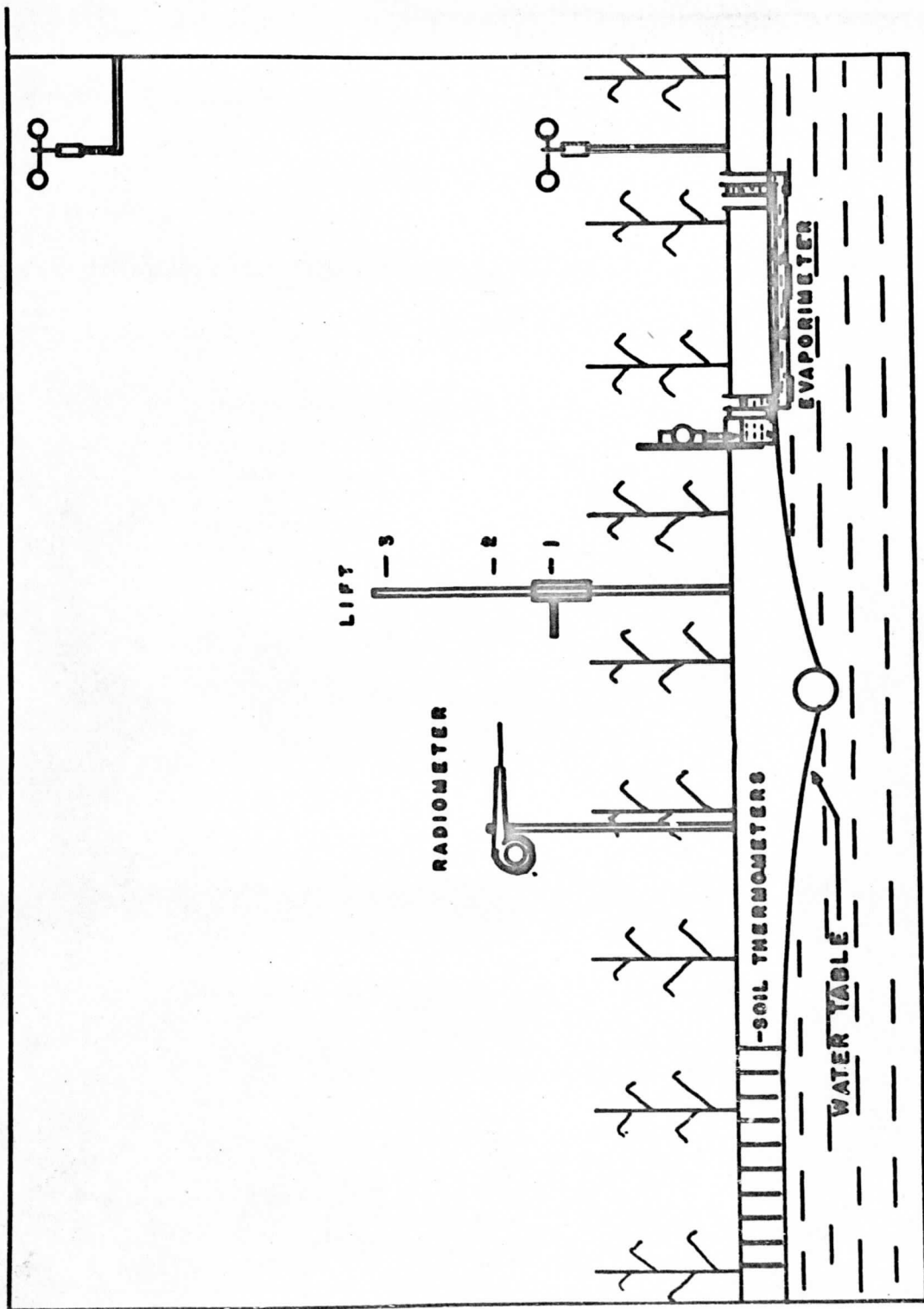

Figure 1

on this conduction relationship where the temperature gradient existing across a thin sheet of bakelite or glass of constant conduction characteristics is measured with alternate junctions of a thin thermopile. A number of heat conduction plates following the construction described by Deacon¹ were made and embedded at various depths and locations in the soil. Results, however, were not satisfactory. When the plates were mounted near the soil surface as was necessary to account for most of the soil heat flow, they interfered with the flow of moisture through the surface and, therefore, with the heat capacity, conductivity, and equilibrium temperature of the soil. On the other hand, if they were set deep enough not to affect the moisture flow, most of the heat transfer occurred above them, thus making it necessary to do calorimetry for that soil layer. Verhrencamp² has used the heat meter method to measure the heat budget of a dry lake bed. Here evaporation and soil moisture changes were negligible. He mounted his heat meters only 2 mm. below the smooth surface and used a soil and water paste to cement them in position.

The calorimetric method of obtaining B_0 requires a measurement of the soil temperature profile and the soil heat capacity. The heat conduction through the surface can then be obtained from the expression

¹Ibid.

²J.E. Verhrencamp, "Experimental Investigation of Heat Transfer at an Air-Earth Interface," Trans. Amer. Geophys. Union, 34 (1953), p. 22.

$$B_0 = 1/\kappa \sum_{i=0}^z \rho_s C_s \Delta T \quad (5)$$

where C_s is the specific heat per unit mass and ρ_s is the soil density. ΔT is the temperature change of each layer for the period in question. Eight thermocouples at various depths were set out from a main support similar to the arms of a series of stacked letter E's so as not to disturb the structure of the soil. The soil conduction terms for May 28-29 and June 26-27 were obtained with this apparatus. It was found necessary to adjust the specific heat of the soil from .74 to .80 to keep from getting inconsistent results in the remainder of the heat budget. Apparently hand cultivation in the immediate vicinity of the temperature probe did not quite duplicate what was done by the farm machinery elsewhere.

Referring to equation (5) one sees that there is not much point in getting a profile of the temperature without at the same time having a profile of the soil heat capacity. It is difficult to sample thin layers of soil so the mean heat capacity for 0-7 cm, 7-20 cm, and 20-30 cm layers were taken. The heat capacity per unit volume for each sample was obtained with an electric calorimeter.

Since the final use of the soil temperature profile is to obtain the average temperature change for the entire layer, it is much simpler to do the actual averaging with a long resistance thermometer element. Better sampling was also obtained by using ten nickel resistance thermometers 30 cm long connected in series

with appropriate compensation leads.¹ These elements were set across ten rows, each element representing a different part of the row. The temperature change was obtained from resistance changes which were measured on a Wheatstone bridge. This method of obtaining B_0 was the best of the three methods tried. Moreover, the equipment was easy to build, calibrate, and use. The advantage gained in having a better statistical sample outweighs the error introduced by using the product of the mean temperature and mean soil heat capacity instead of the mean of their product.

After a series of tests in which all three methods of measuring the soil heat conduction term were compared, the soil temperature profile and heat meter methods were abandoned. The data for August 27-28 and September 2-5 were obtained with the ten resistance thermometers. Hourly measurements of heat capacity were also taken. This method gave an error of 5 per cent of the soil conduction term, thus only 1 to 2 per cent of the total.

D. Temperature and moisture gradient.--Ordinarily, temperature and vapor pressure profiles near the earth's surface are obtained by measuring the difference in temperature of thermocouples set into two or more psychrometers. The use of instruments of similar construction and exposure together with the difference measurement tends to eliminate most of the errors in absolute magnitude. However, Pasquill² states that, in spite of care

¹Heinz Lettau (private communication) has called the writer's attention to a paper by P. Lehman. The paper is entitled "Ein Integrator für Wärme Umsatz Messungen in Boden," *Berichte d. Deutschen Wetterdienstes i.d. U.S. Zone*, 35 (1952), p. 304. Lehman uses only one resistance wire thermometer.

²F. Pasquill, "A Portable Indicating Apparatus for the

in construction and exposure, enough errors remain to warrant frequent zero checks. Presumably these residual errors are due to differences in wet bulb feeding, imperfect wet bulb performance, dirt accumulation, and spurious thermal e.m.f.'s.

The temperature and vapor pressure gradients for this experiment were obtained with a single psychrometer similar to the one described by Pasquill¹ mounted on an automatic electric lift. The psychrometer's position was changed from 10 cm to 33 cm to 100 cm, back to 10 cm, and so on every 80 seconds. The 80-second interval gave 14 observations per hour of dry bulb temperature and wet bulb depression for each height. The remaining 60 seconds of the sequencing interval were used to record zero's and the other parameters. It was found helpful to include a reference mark to indicate when the lift was at the bottom position. With this scheme each measurement had the same wet and dry bulbs, same thermojunctions, same soldered connections, same wires, same relay contacts, same potentiometer recorder, same pen, same chart, same zero check, and approached the reading from the same direction, thus giving the same dead zone error. While this last statement seems to be overemphasizing details, every one of these points could be a source of systematic error which would cause concern when dealing with small gradients.

In addition to the precautions mentioned above, the thermal mass of the dry bulb was adjusted until it had the same

Study of Temperature and Humidity Profiles near the Ground,"
Proc. Roy. Meteor. S., 75 (1949), p. 241.

¹Ibid., p. 240.

time constant as the wet bulb. Spilhaus¹ has shown that unequal time constants will introduce an error during unsteady conditions.

Apart from the strictly instrumental sources of error, there remains the effect of the fluctuations of temperature and vapor pressure on the accuracy of the hourly means. The large thermal mass of the psychrometer bulbs removed fluctuations whose periods were shorter than 10 seconds. However, large fluctuations of a much longer period remained. Shannon,² in his development of communication theory, has shown that in order to reproduce completely a signal whose highest frequency has a period τ , it is necessary to take samples at twice the highest frequency or every $\tau/2$ seconds. This requirement was certainly not met in our equipment, nor can it ever be as long as measurements are made in three places with the same instrument. In order to gather more samples, the time constant must be shortened to allow more rapid adjustment to the new environment. This in turn would increase the band width and would raise the highest frequency of the signal. The two properties are antagonistic. Of course, one can sample rapidly first and integrate later, but the two cannot be combined in one instrument.

An error analysis of $\partial T/\partial z$ and $\partial e/\partial z$ for eight hours of data for May 28, 1952 under unstable conditions and four hours of data under stable conditions was carried out by Mr. Norman Islitzer

¹A.F. Spilhaus, Trans. Roy. Soc. South Africa, Cape Town, 24 (1936), p. 185.

²Claude E. Shannon, "Communication in the Presence of Noise," Proceedings of the Institute of Radio Engineers, 37 (1949), pp. 10-21.

and Mr. Chi-Ling Lee. If the observations at each level are considered independent of each other, the standard error of the mean is about 15 to 20 per cent of the gradient being measured. This represents the maximum error. If the fluctuations at the two levels are related, the error is much less. When the correlation coefficient between psychrometer readings at one level and another equivalent psychrometer of identical characteristics at another level is .9, the standard error of the mean is only 4 to 6 per cent of the gradient being measured. This represents the lower limit of the error. If the correlation is .8, the standard error of the mean is 8 to 10 per cent. It was not possible to establish the correlation coefficient between T_{10} , T_{33} and T_{100} because of having only a single psychrometer. Data presented by Geiger,¹ Gerhardt and Gordon,² and Rider and Robinson³ indicate that $r = .8$ is a reasonable value.

E. Evaporimeter.--The evaporimeter was used to obtain direct measurements of the latent heat flux. It consisted of a tank 20 inches deep and 60 inches in diameter floating in another tank 66 inches in diameter. The inner tank was filled with earth which held full sized corn plants arranged in rows to simulate the surrounding area. These plants were transplanted about three weeks before the measurements were taken. Whole blocks of earth were moved to prevent disturbing the root system. Rain which packed

¹Rudolf Geiger, Climate near the Ground (Cambridge: Harvard University Press, 1950), p. 55.

²J.R. Gerhardt and W.E. Gordon, "Microtemperature Fluctuations," Jour. Meteor., 5 (1948), p. 199, fig. 4.

³Rider and Robinson, op. cit., p. 391, fig. 5.

the earth occurred several times in the three week interval. There was no wilting or other apparent damage to the plants. On the whole the evaporimeter was an excellent sample of the surroundings. It was not possible to distinguish it from the surroundings when viewed from above on a 100-foot tower 100 feet away.

The surface of the water in the "moat" was covered with oil to prevent water loss from evaporation. A Hooke gauge and stilling well enabled the change in mass to be measured from the use of Archimedes' principle. Changes in the water level could be read to .001 ft. (.3 mm) and were estimated to .0001 ft. (.03 mm). The resolution of the evaporimeter was not good enough to obtain hourly values of evaporation. However, since the water loss was cumulative, the percentage error was only about 3-4 per cent for periods of several hours.

The accuracy of the direct evaporation measurement was not limited by the accuracy of the water level measurement but by the area the evaporimeter was set to represent. This area was not the surface area of the inner tank. Instead, the area was chosen to equal that represented by an equivalent length of plant row held by the evaporimeter as shown in figure 2.

These details have been given because the data given by this instrument are an important part of the discussion.

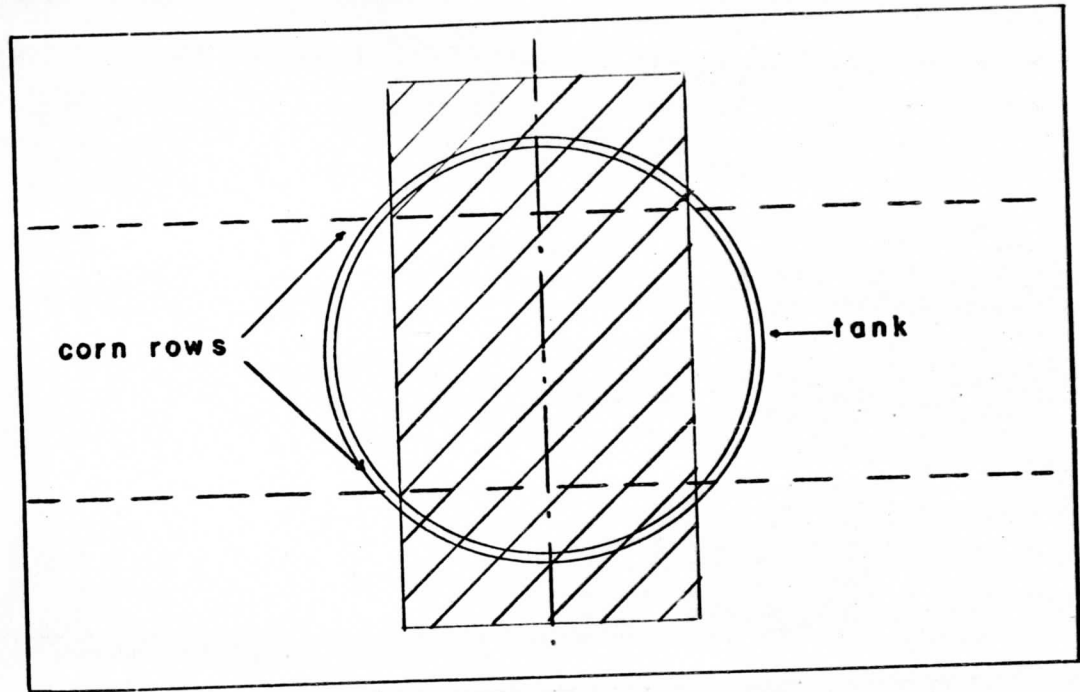

Fig. 2.--Method of obtaining effective area for evaporimeter.

CHAPTER III

DISCUSSION

I. Accuracy of Measurements

A. Radiation and soil conduction terms.--The values of energy tabulated for net radiation and soil conduction in the tables and diagrams that follow can be considered quite reliable. This is especially true of the August and September data where a superior model of the net radiation instrument was used. These data have been corrected for a small error due to the variability of the absorption coefficient with wavelength of the radiation receiver. The soil term for this period was also under finer control because of the method of sampling and the frequent heat capacity determinations.

B. Bowen ratio.--The least precise parts of the measurements were the temperature and vapor pressure gradients, especially at night when they were small. The gradients were measured at two heights to test whether or not the Bowen ratio was constant with height. There is fair evidence that this was true for the May data, but in June the corn plants had grown high enough to effect the lowest gradient. By late August the corn was full-grown, and a new lift with stops at 237 cm, 342 cm, and 484 cm above the soil was necessary to get the measurements above the corn crop. During the day the lowest level gradients could not be used since it was found that a measurement made slightly above, but between vegeta-

tion rows, was still not out of the fetch of the roughness elements.¹ Apparently it is necessary to take both time and space averages when working near an inhomogeneous surface. During the time that the net radiation was positive, that is, at night, the lowest gradients were used for the Bowen ratio. During this time, the upper level gradients were too small to allow the Bowen ratio to be obtained with any accuracy. The switch from upper to lower gradient is marked in the tables by the horizontal bar.

It would seem reasonable, on purely physical grounds, to expect smooth curves for the hourly values of sensible and latent heat transfer on days with clear sky and uniform wind. If this assumption is valid, the difference between the smooth curve and the actual observation can be expressed as a percentage error of the gradient being measured. A band representing the ± 5 per cent error limit of latent heat flux has been added to the chart for September 5, figure 7. Only the 0900 value lies outside the band. This large departure must have been caused by faulty operation of the lift, wet bulb, or recorder rather than representing a typical error of measurement. The noon observation for each clear day in August and September, figures 5, 6, 7 and 9, also have significant departures from a smooth curve. During twenty minutes of this hour the rows of corn were in line with the sun. Each plant was then shading its neighbor to the north. This "row effect" was also evident in the individual sample gradients of temperature

¹Heinz Lettau (private communication) has treated this problem theoretically in the Proceedings of a Symposium on Atmospheric Turbulence, Air Force Cambridge Research Center, Cambridge, Mass., E. Wendell Hewson Editor (in press), 1953.

and moisture during the twenty minute period. The effect is also apparent in the wind data. Some of the indicated changes in the heat budget at noon are undoubtedly real, but there is no way to assess it quantitatively from the present set of observations

II. Comparison of Direct and Bowen Ratio Measurements of Sensible and Latent Heat

A. Latent heat.--A test of the accuracy of the Bowen ratio method is given by comparing its values of the latent heat flux with those obtained by direct measurement. This is shown in Table 1. The difference in the two results contains the net error of all of the measurements as well as any error introduced by the lack of realistic assumptions in the Bowen ratio concept. However, the errors in measurement will tend to be random whereas the error attributed to the use of the Bowen ratio will be systematic. There is rather good agreement between direct and indirect measurements except for September 4. This day's data will be treated separately in a later paragraph.

It is of interest to recall that the theoretical objections to the assumption that $A_v = A_b$ as used in the derivation of the Bowen ratio, are such as to lead one to overestimate the evaporation. Table 1 shows this same tendency. One is tempted to state that these results confirm Pasquill's measurements.¹ Unfortunately in both his and our experiments the absolute magnitude of the evaporation term depends on the surface area assigned to the evaporimeter. While this is straightforward enough for the evaporimeter container, the area represented by the vegetation is quite another matter. It could be in error by 5-10 per cent.

¹F. Pasquill, "Eddy Diffusion of Water Vapor and Heat near the Ground," Proc. Roy. Soc., Ser. A, 198 (1949), pp. 136 f.

TABLE 1
COMPARISON OF DIRECT AND BOWEN RATIO
MEASUREMENTS OF LATENT HEAT

Date	Time	E_{direct}	E_{Bowen}	Error	E_{smooth}^*	Error
Sept. 2	1000-1700	62	68	+ 9%	---	+ 9%
Sept. 3	0700-1700	144	145	+ 1%	151	+ 5%
Sept. 4	0700-1700	193	152	-21%	157	-13%
Sept. 5	0700-1200	109	105	- 4%	111	+ 2%

*The smoothing in Table 1 consists of linear interpolation for one large, easily detected departure on Sept. 4 and 5 and two departures of opposite sign on Sept. 3. No smoothing of the Sept. 2 data was attempted because of the variable radiation. The units of Table 1 are Langleys.

B. Sensible heat.--The values of sensible heat obtained from the Bowen ratio and as the residue of the direct measurements are given in Table 2.

TABLE 2
COMPARISON OF RESIDUE AND BOWEN RATIO
MEASUREMENTS OF SENSIBLE HEAT

Date	Time	L_{residue}	L_{Bowen}	Error	L_{Smooth}	Error
Sept. 2	1000-1700	44	38	-13%	---	-13%
Sept. 3	0700-1700	120	119	- 1%	113	- 8%
Sept. 4	0700-1700	58	99	---	94	---
Sept. 5	0700-1200	32	36	+11%	30	- 6%

The values of the sensible heat listed in Table 2 are easily accurate enough to meet the needs of a test of the effects of a variable density gradient on turbulence near the ground, outlined in the introduction to this paper.

III. The Effect of Advection

In this section we will attempt to account for the large discrepancy between the direct and indirect latent heat loss measurements of September 4.

Equation (1) was written as the heat budget of a horizontal surface, each term representing heat transport in the vertical direction only. If we write the heat budget for a volume whose bottom surface is in contact with the ground, we must account for energy added through its vertical faces. Equation (1) then becomes

$$R_{484} + B_0 + E_{484} + L_{484} = A \quad (6)$$

if we neglect certain terms we have already shown to be small. The subscript used refers to the height of the instruments. The first three terms are the direct measurements. It is clear that the residue is more than just the sensible heat. If we assume that $E_0 = E_{484}$ as was done in (6), and also assume that we can use the average measured Bowen ratio, weighted for the total heat added to the atmosphere during each hour, we can obtain L_{484} from $\bar{\beta} E_{484}$. The total sensible heat flux for the period 0700-1700 on September 4 is 114 langley. When this figure and the other measured values are substituted into (6), we obtain $A = 56 \text{ Ly}$. If this estimate of the advection is reasonable,

it is clear that during conditions with advection, the Bowen ratio method of balancing the heat budget will have large errors.

A question now arises. Is there some measurable parameter other than direct water loss that would allow an estimate of the advected energy? An approximate solution to this question is found in the soil conduction term. If we ignore the seasonal transmission of heat into the ground, and also assume an equal ratio of heat added to the soil to that added to the atmosphere for successive clear days, the total heat flux into the soil averaged over a 24 hour period will be zero. An inspection of the soil temperature curve of September 4 in figure 3 shows an accumulation of 9.8 Ly. from morning to midnight. We assume this to be due to advection.

In order to obtain an estimate of A, it is now necessary to make use of a plausible but unverified assumption, namely, that the ratio of soil conduction due to advection to the total change in soil conduction is equal to the ratio of the advected energy to the total radiant energy change, thus

$$\frac{(B_o)_{adv}}{|B_o|} = \frac{A}{|R_{484}|} \quad (7)$$

The total change for soil and radiation was taken as the area under each curve from the equilibrium value existing before sunrise to the one obtained after sunset. See figure 6. This was done to overcome the difficulty due to the phase difference existing between the net radiation wave and the soil conduction

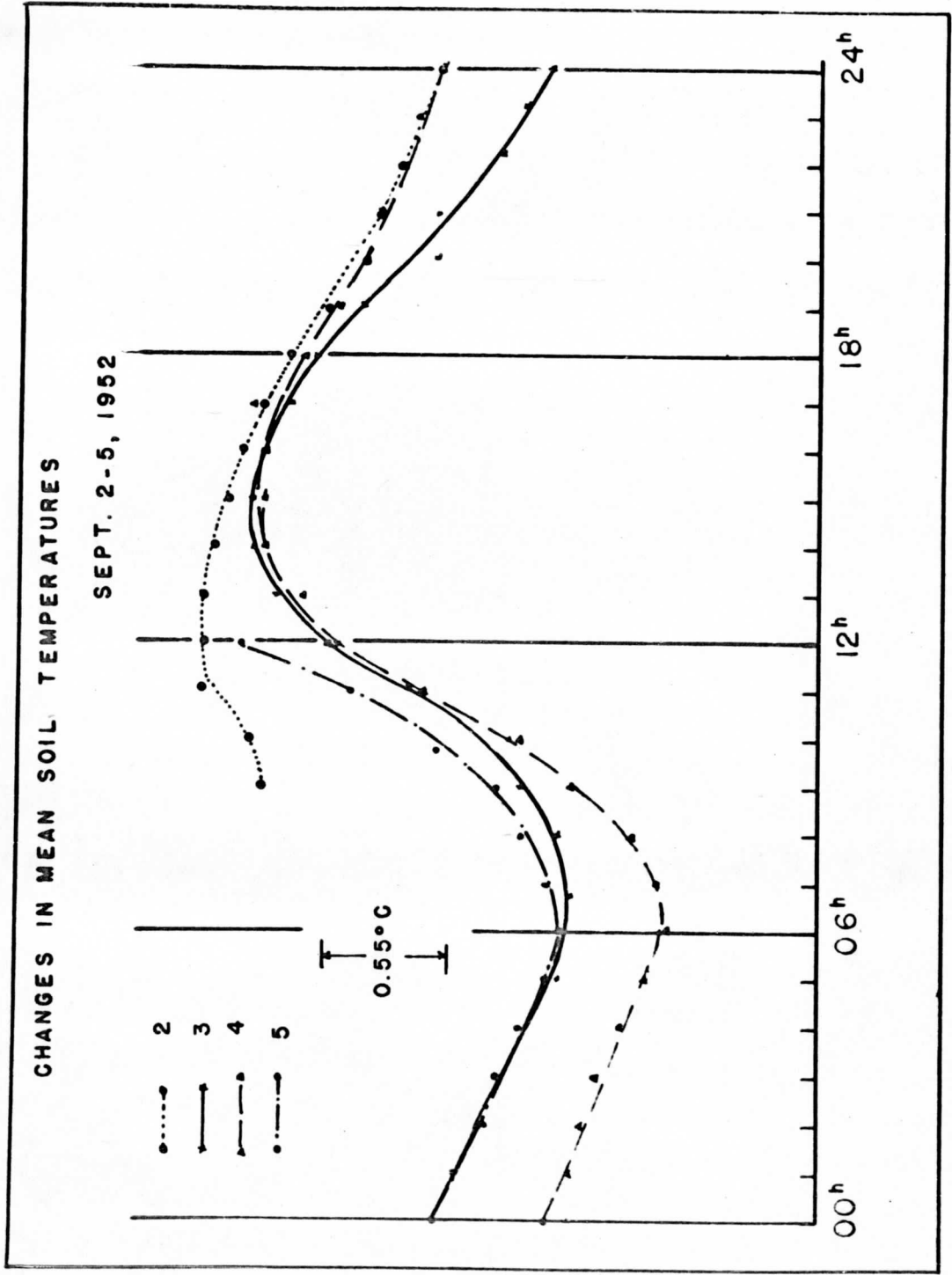

Figure 3

wave. When these values are substituted into (7) we have $A = 54$ Langleys.

This value of A and the weighted mean measured Bowen ratio allow equation (6) to be solved for E_{484} . We obtain 191 Ly. as the estimated value of the latent heat term which compares favorably with 193 Ly., the value of E_0 obtained by direct measurement. The excellent agreement is to some extent good luck; however, it does appear that a fair estimate of the advected energy can be obtained from the soil conduction term. A summary of the latent heat data is given in figure 8.

IV. Conclusion

We set out to answer the question, "What happens to the sunlight?," and obtained some measurements by applying the principle of the conservation of energy to a surface in the form of a cornfield. Some of the data, that for May, June, and August, however accurate, merely show that the various terms fluctuate in a manner to be expected. Aside from some descriptive value and certain agricultural applications, they cannot be used in any test. In September we were fortunate in having semi-laboratory conditions and were able to show, within the limitations of our experiment, that values of sensible and latent heat flux accurate to better than 10 per cent can be obtained from heat budget measurements. It would be presumptuous to state that the above results illustrate conclusively that total evaporation can be obtained from heat budget measurements alone. The results do indicate that the energy balance does give useful values during periods of little or no advection. If the soil term is measured with

sufficient accuracy, a reasonable estimate of the advected energy is possible. This method of estimating the advection term should be tested further because of its application to certain agricultural problems.

The theory of the boundary layer has been developed to the point where its demands for observational material far exceeds what is available. The real value of an experiment such as we have done will be in repeating it under similar conditions together with careful measurements of wind profile, roughness, and the other measureable parameters the theories purport to relate. Such a test will indicate whether or not the present "Austauch" approach to the problems of the boundary layer, which assumes no net vertical motions, will be fruitful toward a better understanding of part of the complex phenomena we call weather.

V. Data

The hourly mean values of the four terms in the heat budget as well as other pertinent data are listed in the following charts and tables. Net radiation is plotted positive downward in order to conserve space on the charts.

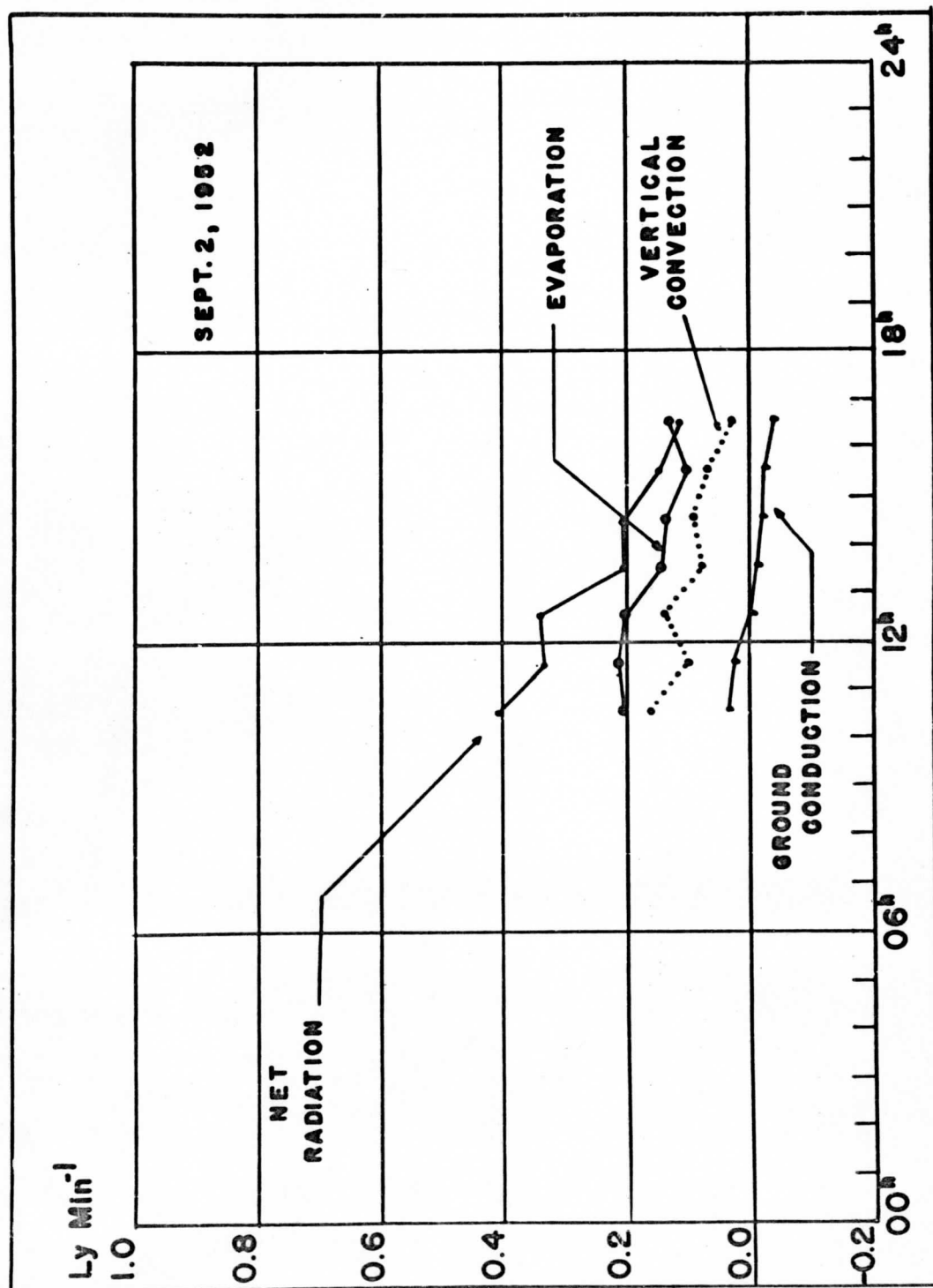

Figure 4

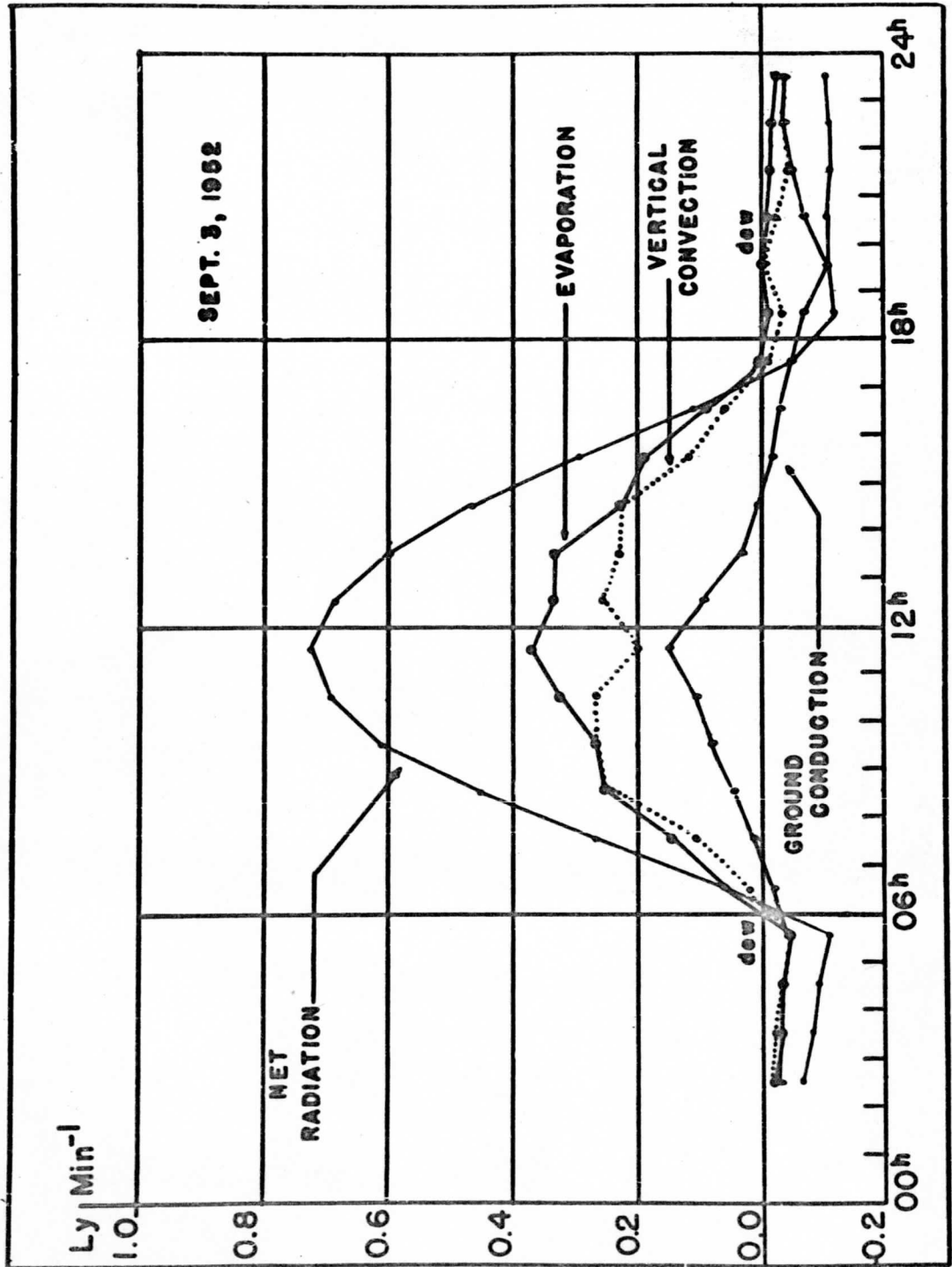

Figure 5

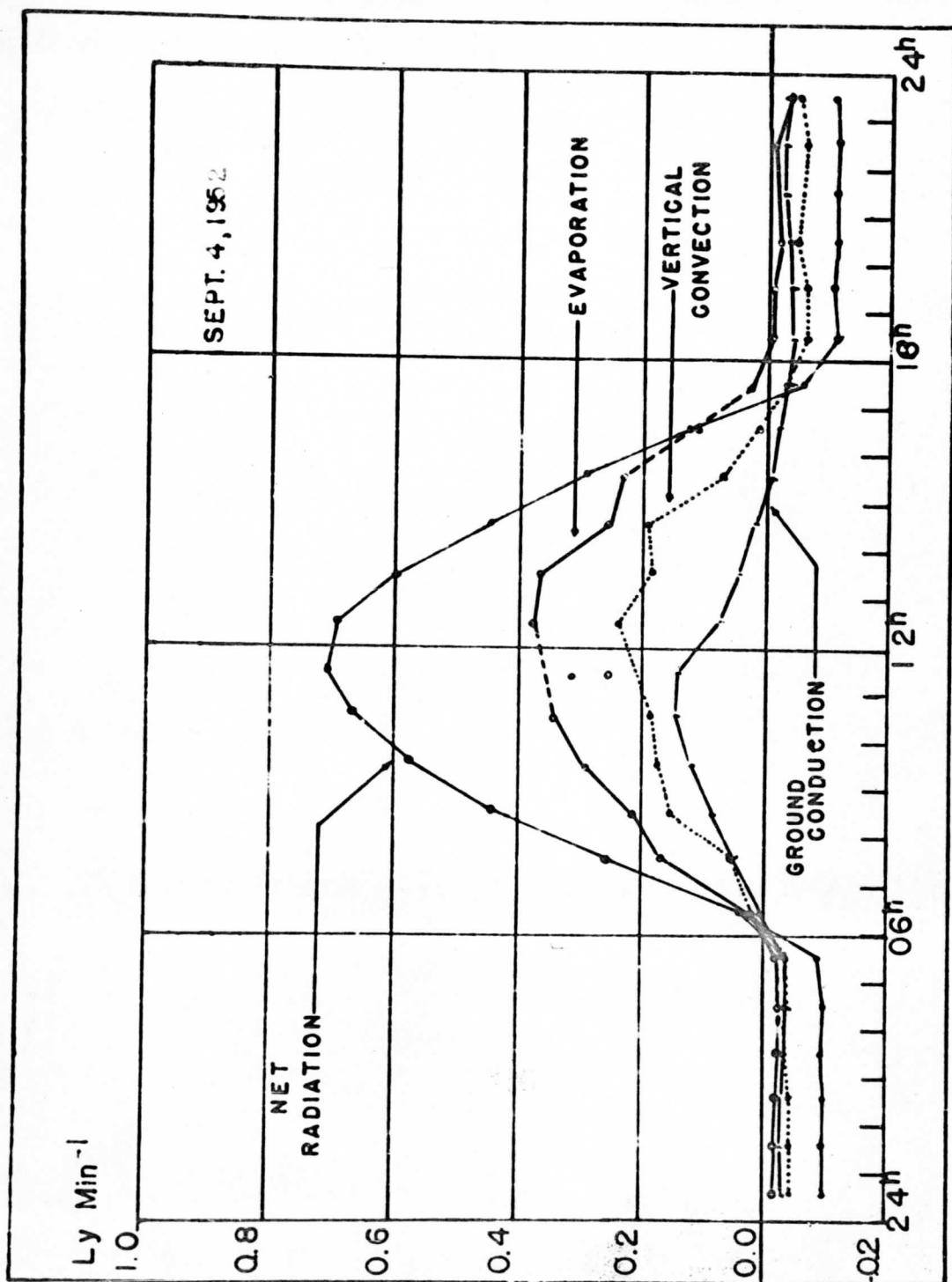

Figure 6

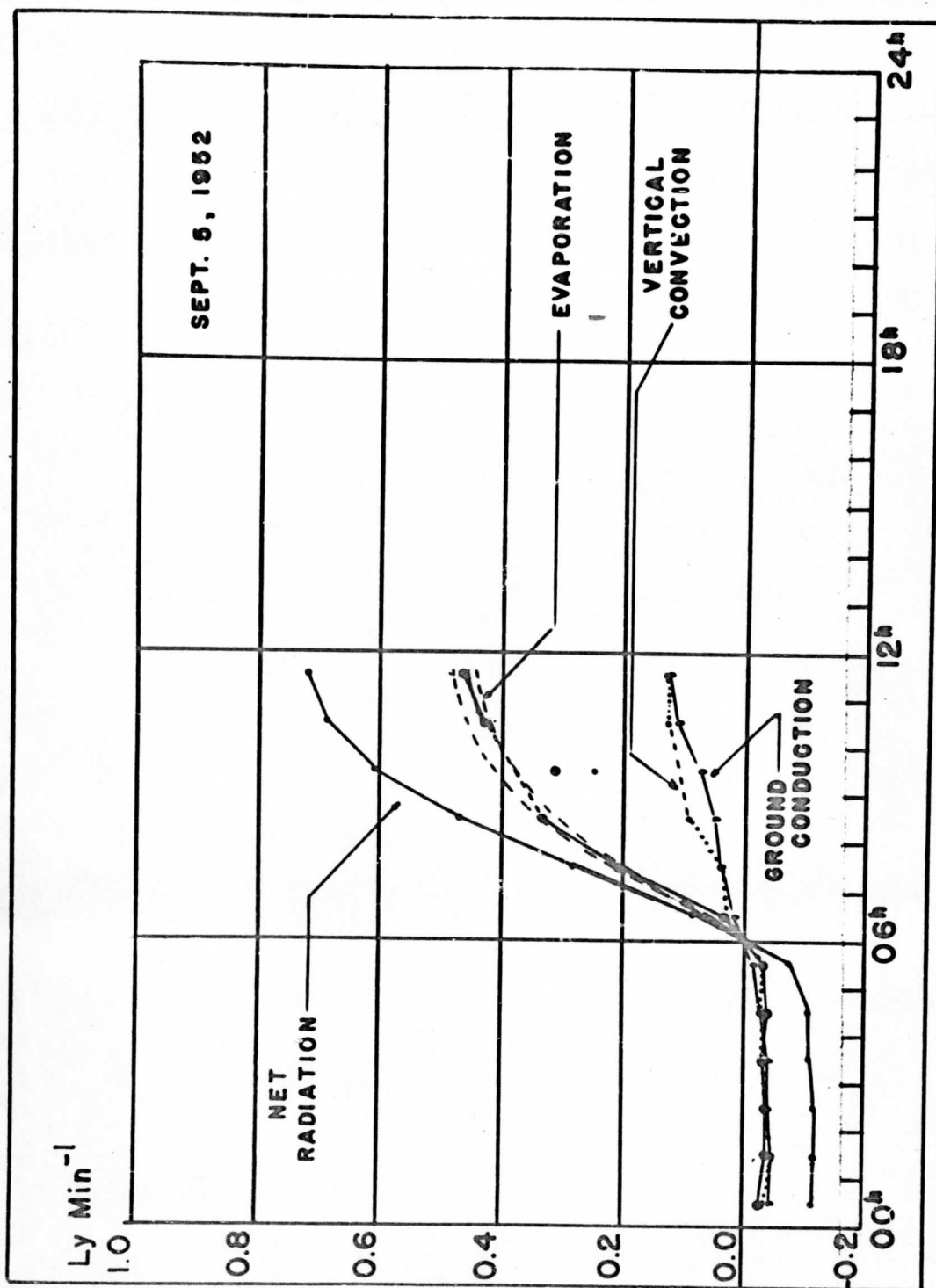

Figure 7

Comparison of latent heat loss

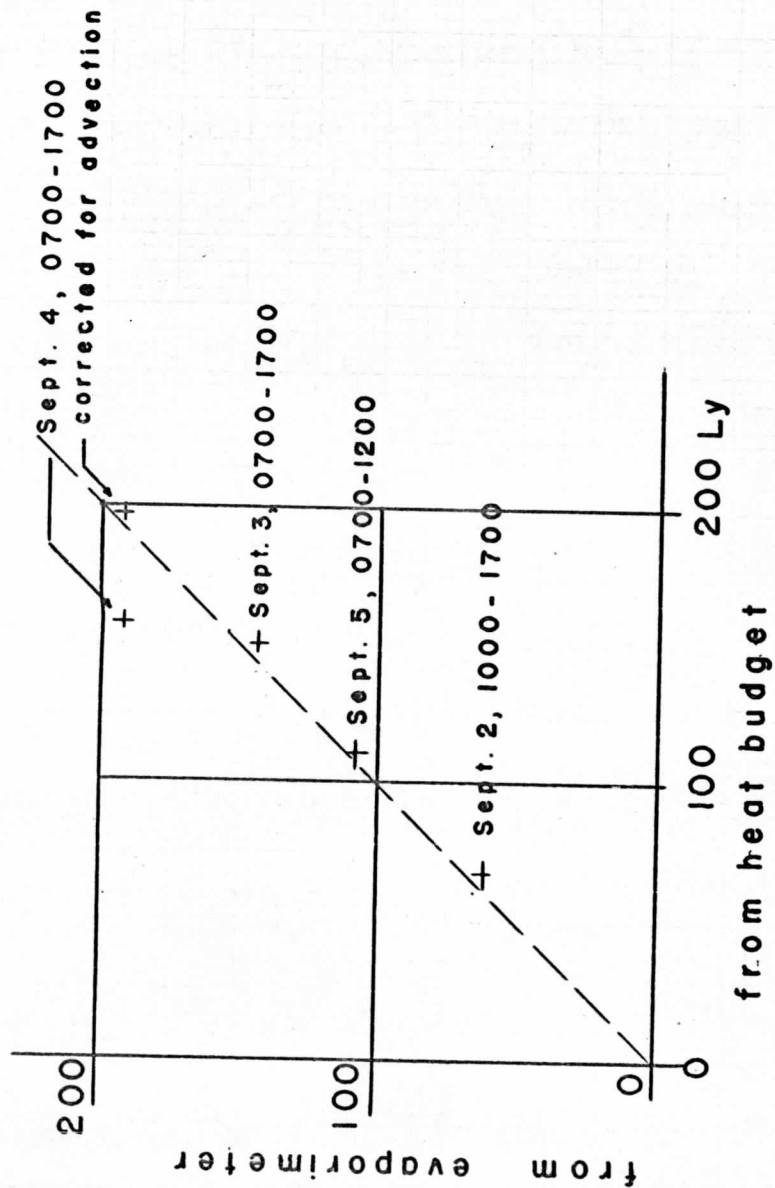

Figure 8

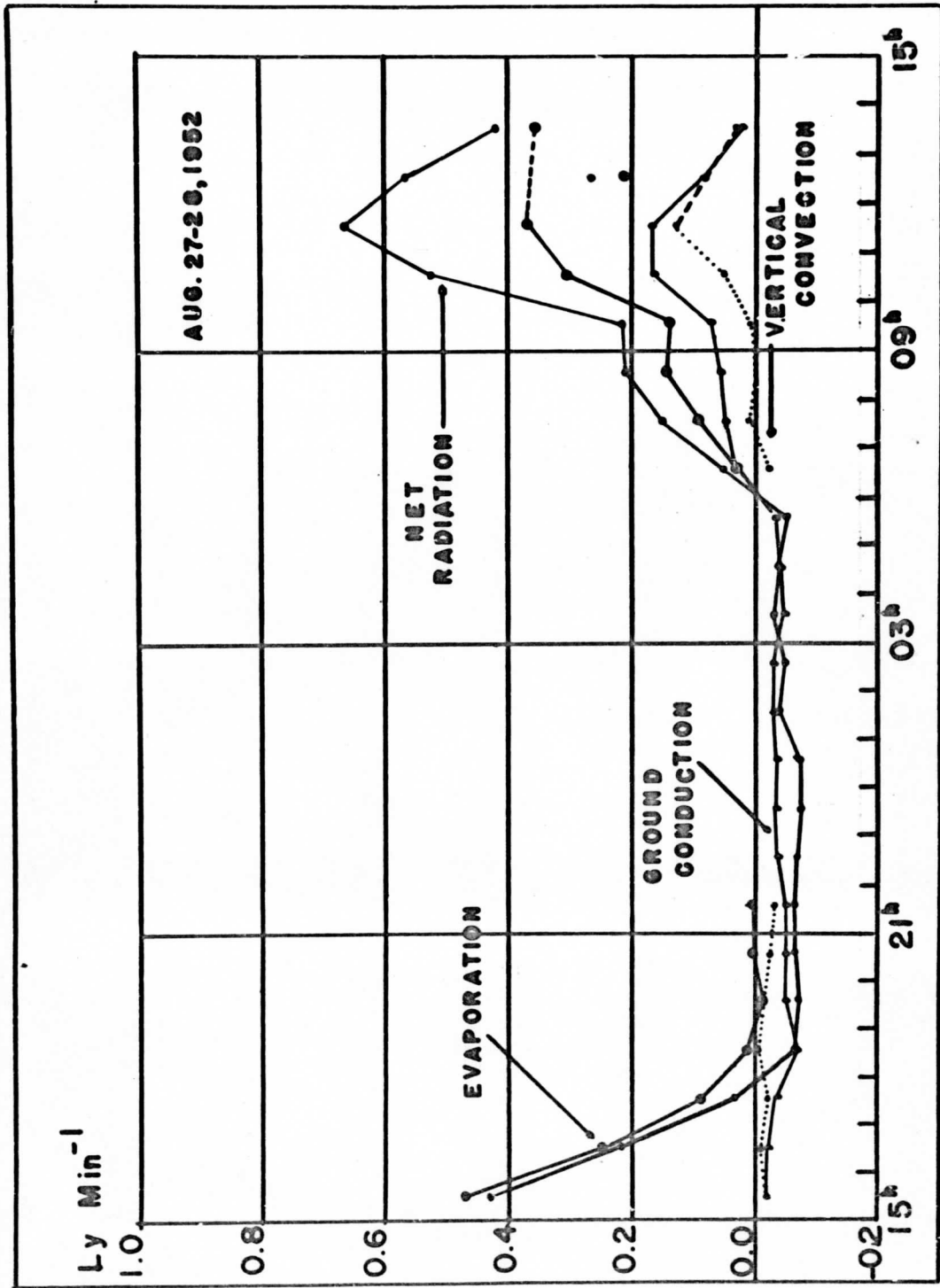

Figure 9

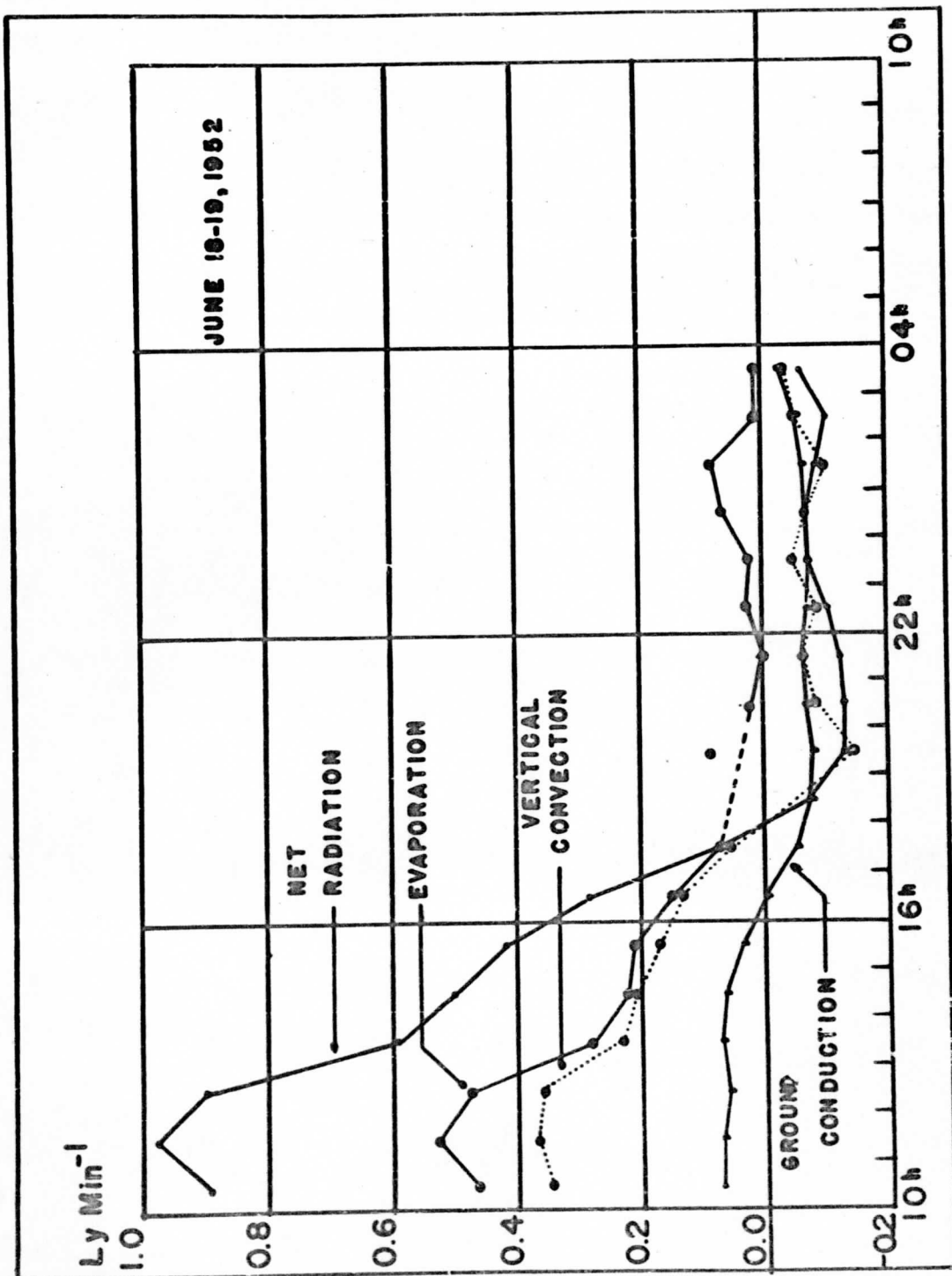

Figure 10

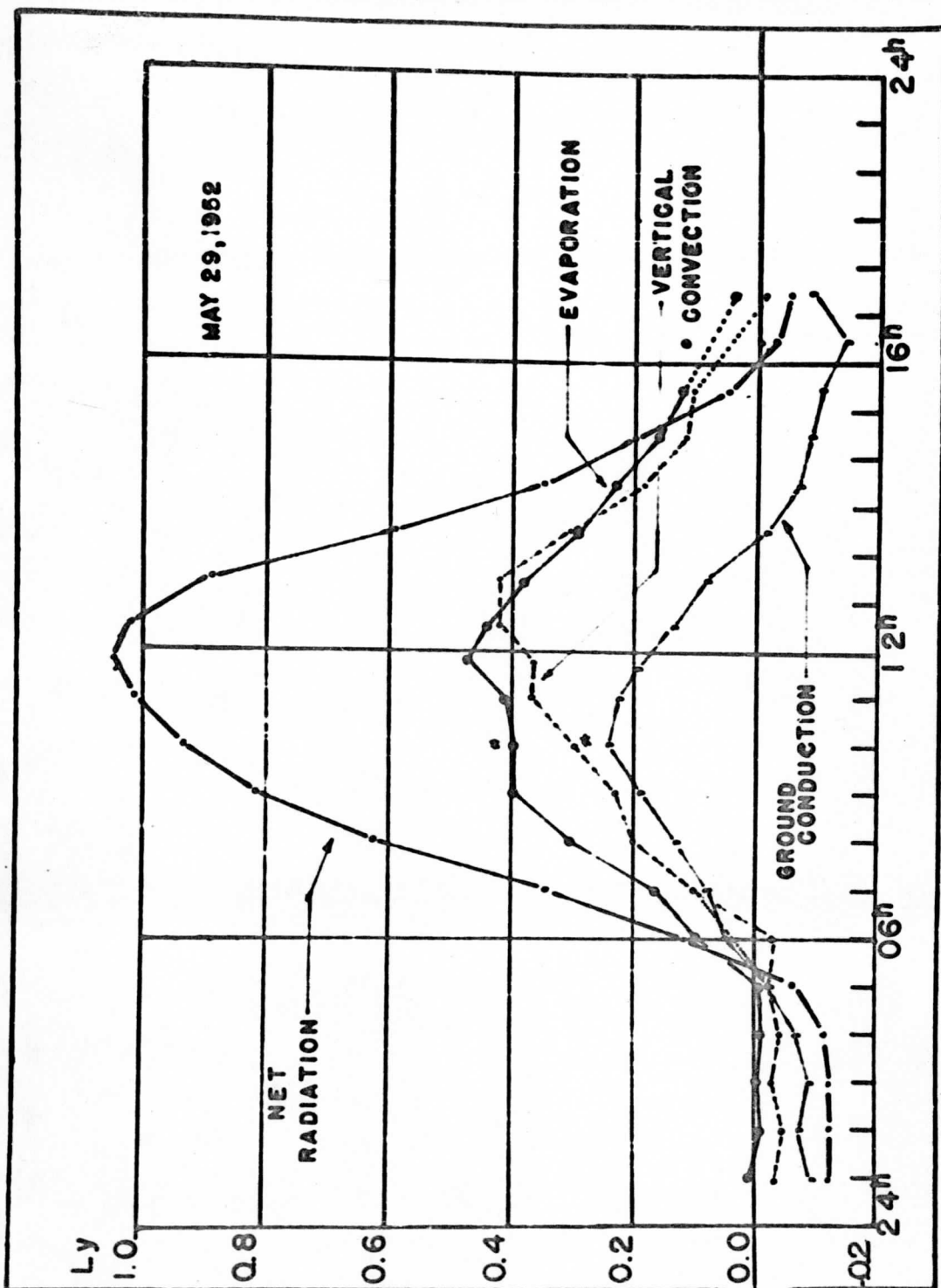

Figure 11

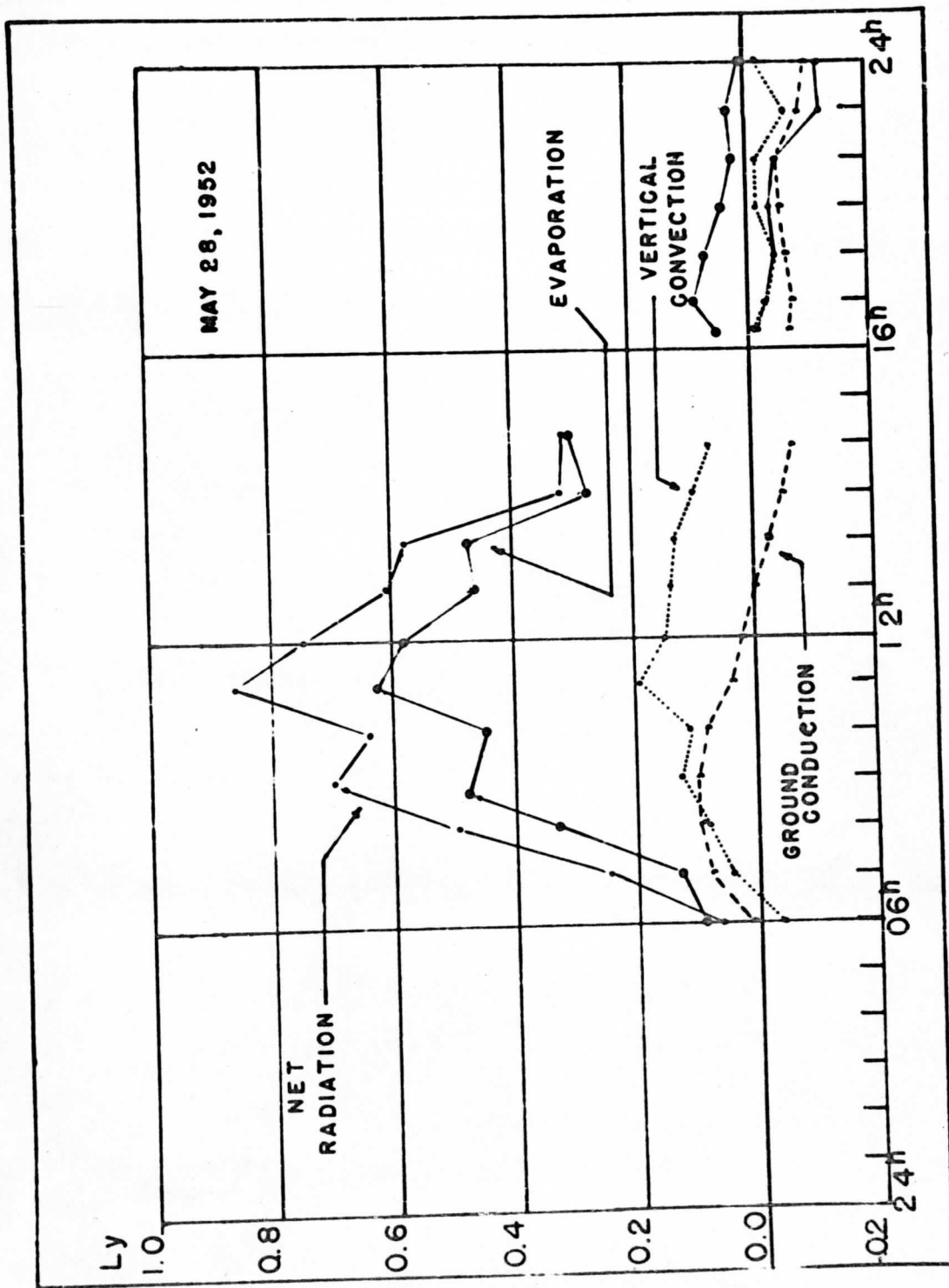

Figure 12

TABLE 3
HEAT BUDGET OVER UNIVERSITY OF WISCONSIN
MARSH FARM CORNFIELD

Time	$-R_{484}$	B_o	β	E_{484}	L_{484}	T_o °C.	T_{150} °C.
Sept. 2							
1000-1105	405	38	.78	206	161	16.4	14.3
1105-1200	334	26	.45	212	96	16.8	14.2
1200-1300	340	- 4	.68	205	139	16.8	14.6
1300-1400	203	- 14	.53	142	75	16.6	14.6
1400-1500	205	- 20	.64	137	88	16.2	14.2
1500-1600	144	- 26	.65	103	67	16.0	13.7
1600-1700	112	- 38	.16	129	21	15.8	13.0
Sept. 3							
0200-0300	- 64	- 26	1.04	- 18	- 20	14.1	11.9
0300-0400	- 80	- 26	.52	- 35	- 19	14.7	12.0
0400-0500	- 91	- 32	.77	- 33	- 26	14.7	12.0
0500-0600	-110	- 40	.51	- 46	- 24	14.6	12.6
0600-0700	60	- 20	.28	62	18	14.9	13.5
0700-0800	263	14	.74	143	106	15.5	14.3
0800-0900	452	44	.61	252	256	15.9	14.5
0900-1000	610	80	.99	266	264	16.0	14.8
1000-1100	695	106	.81	324	265	16.7	14.4
1100-1200	721	148	.53	374	199	19.8	15.6
1200-1300	684	94	.76	334	256	20.6	16.9
1300-1400	598	30	.69	336	232	19.0	17.6
1400-1500	462	6	1.05	222	234	20.4	18.0
1500-1600	287	- 20	.57	191	116	18.9	18.5
1600-1700	102	- 32	.57	85	59	17.4	18.5
1700-1800	- 54	- 48	.8	4	- 10	16.2	17.7
1800-1900	-121	- 72	2.6	- 13	- 36	15.1	13.6
1900-2000	-107	-110	1.9	1	2	14.4	12.5
2000-2100	-106	- 72	2.2	- 10	- 24	14.1	12.7
2100-2200	-106	- 48	2.8	- 15	- 43	14.3	12.9
2200-2300	-100	- 40	1.8	- 21	- 39	14.3	12.6
2300-2400	-104	- 38	1.5	- 26	- 40	14.3	12.4

TABLE 3--Continued

emb 150	$T_{484} - T_{342}$	$e_{484} - e_{342}$	u_3 M/sec.	u_{30} M/sec.	$\frac{u_{30} M.}{u_B M.}$	dd	Cloud
10.5	-0.28	-0.23	3.05	6.02	1.97	NW	8 Sc
10.6	-0.31	-0.44	2.77	5.25	1.90	NW	9 Sc
10.6	-0.20	-0.19	3.02	6.00	1.99	WNW	9 Sc
10.7	-0.10	-0.12	2.78	5.63	2.02	WNW	10 Sc
10.5	-0.12	-0.12	3.22	6.69	2.07	WNW	10 Sc
10.5	-0.06	-0.06	3.25	6.50	2.01	WNW	10 Sc
10.7	-0.01	-0.04	3.07	6.08	1.98	WNW	10 Sc
11.6	.13	.08	1.73	3.32	2.26	NW	9 Sc
12.1	.30	.37	1.37	3.02	2.64	NW	9 Sc
12.6	.41	.34	1.46	4.15	2.85	NW	3 Sc
13.3	.22	.28	1.18	3.32	2.82	NW	1 C1
13.8	.13	.30	1.36	3.20	2.34	NW	1 Cu
13.7	-.15	-.13	1.65	3.55	2.16	NW	1 Cu
12.8	-.17	-.18	1.62	3.25	2.01	NW	0 --
11.2	-.37	-.24	1.83	3.83	1.82	NW	0 --
9.8	-.57	-.45	1.52	2.81	1.84	NW	0 --
9.9	-.29	-.35	1.55	3.04	1.95	NW	0 --
10.1	-.40	-.34	2.04	4.18	2.05	NW	0 --
10.4	-.40	-.37	1.29	2.87	2.24	NW	0 --
10.5	-.33	-.20	1.71	2.78	1.62	NW	0 --
10.9	-.32	-.36	1.16	2.53	2.20	NW	0 --
11.0	-.08	-.09	1.48	2.71	1.80	NW	0 --
11.5	.05	.04	---	2.10	---	W	0 --
13.1	.73	.18	---	1.54	---	W	0 --
12.4	1.83	.62	---	1.44	---	W	0 --
12.0	1.68	.50	---	2.09	---	W	0 --
11.9	.78	.18	---	2.85	---	W	0 --
11.5	.57	.20	.85	3.75	---	W	3 C1
11.4	.57	.24	.81	3.22	---	SW	3 C1

TABLE 3--Continued

Time	-R ₄₈₄	B _o	β	E ₄₈₄	L ₄₈₄	T _o °C.	T _o °C. 150
Sept. 4							
2400-0100	-104	- 36	2.5	- 21	- 47	14.2	12.2
0100-0200	-104	- 30	1.8	- 23	- 41	14.2	12.3
0200-0300	-102	- 30	1.5	- 29	- 43	14.2	12.2
0300-0400	-100	- 32	1.3	- 29	- 38	14.2	12.0
0400-0500	-102	- 41	1.6	- 23	- 38	14.2	11.8
0500-0600	- 95	- 32	1.4	- 26	- 37	14.1	12.4
0600-0700	36	16	.56	13	7	14.2	13.8
0700-0800	254	44	.27	165	45	15.0	16.0
0800-0900	443	80	.70	218	152	15.8	17.1
0900-1000	578	118	.61	286	174	16.1	18.5
1000-1100	666	142	.54	340	184	16.7	19.6
1100-1200	709	140	1.23	255	314	20.4	20.5
1200-1300	691	74	.63	379	238	22.1	21.5
1300-1400	596	40	.49	373	183	19.8	22.2
1400-1500	456	14	.75	252	190	21.4	22.8
1500-1600	289	- 4	.27	230	63	19.9	23.0
1600-1700	110	- 24	.04	12	112	17.9	22.7
1700-1800	- 60	- 41	-1.86	21	- 39	16.8	21.5
1800-1900	-120	- 46	7.27	- 9	- 65	15.8	18.9
1900-2000	-116	- 40	5.3	- 12	- 64	15.3	17.2
2000-2100	-119	- 38	2.1	- 26	- 55	15.3	17.2
2100-2200	-118	- 32	0.0	---	---	---	17.2
2200-2300	-121	- 30	3.7	- 18	- 72	---	15.9
2300-2400	-119	- 28	1.2	- 40	- 51	---	15.8
Sept. 5							
2400-0100	-116	- 44	1.55	- 28	- 34	---	15.7
0100-0200	-118	- 30	1.28	- 38	- 50	---	15.9
0200-0300	-115	- 34	1.05	- 39	- 42	---	15.2
0300-0400	-107	- 40	.91	- 35	- 32	---	14.5
0400-0500	-105	- 32	.71	- 42	- 31	---	14.4
0500-0600	- 75	- 12	.95	- 33	- 30	---	13.8
0600-0700	83	20	.93	33	30	---	15.5
0700-0800	281	40	.16	204	37	---	17.3
0800-0900	470	50	.26	334	86	---	19.6
0900-1000	609	76	.71	312	219	---	21.9
1000-1100	687	116	.33	428	143	---	23.4
1100-1200	717	130	.27	463	124	---	24.7

TABLE 3--Continued

emb 150	$T_{484} - T_{342}$	$e_{484} - e_{342}$	u_3 M/sec.	u_{30} M/sec.	$\frac{u_{30M.}}{u_B M.}$	dd	Cloud
11.2	.58	.15	.87	3.45	3.94	SW	1 Ci
11.1	.60	.22	.73	3.12	4.22	SW	1 Ci
11.1	.52	.22	.74	3.21	4.35	SW	0 --
11.1	.65	.32	.65	3.10	4.75	SW	1 Ac
11.2	.54	.21	.59	2.97	5.00	SW	0 --
11.6	.39	.17	.86	3.16	3.65	SW	0 --
12.3	.05	-.07	.99	2.76	2.79	SW	0 --
13.0	-.03	-.07	.93	2.55	2.73	SW	0 --
12.8	-.24	-.22	1.63	3.86	2.38	SW	0 --
13.1	-.20	-.21	1.81	3.26	1.81	SW	0 --
13.4	-.31	-.37	2.35	3.90	1.66	SSW	0 --
13.4	-.19	-.10	2.50	4.06	1.62	SSW	0 --
14.1	-.39	-.40	1.92	3.28	1.71	SW	0 --
12.6	-.20	-.26	2.45	3.78	1.72	SW	0 --
12.7	-.13	-.11	2.28	3.81	1.68	SW	0 --
12.8	-.11	-.26	2.14	3.61	1.69	S	0 --
13.3	-.01	-.17	---	---	1.81	S	0 --
14.4	.26	-.05	---	---	2.70	S	0 --
14.4	.80	.07	.76	3.86	5.03	S	0 --
14.2	.91	.11	.71	2.60	3.57	S	0 --
13.8	.05	.12	2.10	4.04	1.92	S	0 --
13.4	.32	.26	2.2	4.06	1.84	S	0 --
13.1	.29	.05	1.73	3.47	2.00	S	0 --
13.0	.38	.21	1.86	3.62	1.94	S	0 --
12.7	.12	.05	2.05	3.82	1.84	S	0 --
12.6	.34	.17	---	---	---	S	0 --
12.8	.36	.22	2.19	3.95	1.80	S	0 --
12.5	.44	.31	1.28	3.08	2.40	S	0 --
12.4	.39	.34	1.60	3.32	2.07	S	0 --
12.4	.47	.32	1.32	2.86	2.17	S	0 --
12.5	.48	.33	2.37	3.92	1.66	S	0 --
12.9	-.02	-.08	2.91	4.80	1.65	S	0 --
14.0	-.04	-.10	---	---	---	S	0 --
15.0	-.11	-.10	3.30	5.08	1.54	S	0 --
16.3	-.13	-.25	2.58	5.65	1.58	S	0 --
17.0	-.17	-.41	3.64	6.05	1.67	SW	0 --

TABLE 4
HEAT BUDGET OVER UNIVERSITY OF WISCONSIN
MARSH FARM CORNFIELD

Time	-R ₄₈₄	B _o	β	E ₄₈₄	L ₄₈₄	T _o °C.	T ₁₅₀ °C.
August 27							
1500-1600	431	- 17	-0.05	472	- 24	29.8	29.2
1600-1700	214	- 19	-0.08	248	- 8	28.6	28.6
1700-1800	30	- 36	-0.23	88	- 22	26.9	27.3
1800-1900	- 63	- 71	-0.39	13	- 5	25.9	25.4
1900-2000	- 73	- 48	-1.10	- 12	- 13	25.0	24.1
2000-2100	- 67	- 48	-5.60	4	- 23	24.5	23.3
2100-2200	- 65	- 48	-1.93	18	- 35	24.2	22.5
2200-2300	- 68	- 36	---	---	---	23.9	21.5
2300-2400	- 74	- 31	---	---	---	23.8	22.3
August 28							
2400-0100	- 74	- 33	---	---	---	23.7	22.1
0100-0200	- 40	- 28	---	---	---	23.6	---
0200-0300	- 47	- 28	---	---	---	23.6	20.2
0300-0400	- 33	- 42	---	---	---	23.3	20.2
0400-0500	- 38	- 42	---	---	---	23.3	20.8
0500-0600	- 48	- 28	---	---	---	23.3	20.0
0600-0700	54	42	-0.64	35	- 23	23.1	21.1
0700-0800	154	50	0.11	94	10	23.7	21.8
0800-0900	204	59	0.00	145	0	24.2	23.4
0900-1000	218	73	0.04	140	5	24.7	24.0
1000-1100	527	167	0.17	309	51	25.5	25.5
1100-1200	669	167	0.35	373	129	26.4	26.5
1200-1300	567	84	1.28	212	271	28.9	27.8
1300-1400	421	28	0.09	361	32	29.6	27.3

TABLE 4--Continued

emb 150	$T_{484} - T_{342}$	$e_{484} - e_{342}$	u_3 M/sec.	u_{30} M/sec.	$\frac{u_{30M.}}{u_B M.}$	dd	Cloud
20.5	0.02	-0.24	3.39	5.15	1.52	S 1	Ci
21.0	0.01	-0.20	2.81	4.53	1.62	S 0	Ci
22.1	0.07	-0.19	1.43	2.94	2.05	S 3	Ci
22.7	0.08	-0.13	1.03	3.17	2.21	S 1	Ci
22.8	0.24	-0.14	1.01	3.33	3.19	SSE 1	Ci
21.6	0.35	-0.04	1.48	5.50	3.72	SSE 0	---
21.4	0.30	-0.10	.24	2.27	9.42	SSE 0	---
21.2	---	---	.41	2.41	5.91	SSE 0	---
19.0	---	---	1.97	3.81	1.93	SSE 0	---
17.3	---	---	1.00	3.68	1.51	SSE 0	---
---	---	---	.88	2.73	3.08	SSE 0	---
17.5	---	---	.58	2.24	4.80	SSE 0	---
17.6	---	---	.50	2.29	4.61	SSE 5	Ac, Sc
17.6	---	---	.41	2.23	5.40	SSE 9	Ac, Sc
17.5	---	---	.85	2.87	3.32	SSW 6	Ac, Sc, Ci
17.6	0.12	-0.12	.39	2.02	5.10	SSW 9	Ac, Sc, Ci
18.4	-0.03	-0.18	.63	2.08	3.28	SW 9	Ac, Sc, Ci
19.3	-0.00	-0.09	.79	3.06	3.90	SSW 9	Ci
20.4	-0.02	-0.29	---	---	---	SSW 9	Ci, Ac, Ad
21.1	-0.12	-0.44	---	---	1.87	SW 6	Ci, Ac, Sc
21.8	-0.33	-0.60	1.21	2.03	1.62	SW 6	Ci
24.8	-0.08	-0.04	---	---	---	SW 7	Ci, Ac, Cu
25.3	-0.10	-0.72	---	---	---	SW 7	Ci, Ac, Cu

TABLE 5
HEAT BUDGET OVER UNIVERSITY OF WISCONSIN
MARSH FARM CORNFIELD

Time	$-R_{100}$	B_o	β	E_{100}	L_{100}	T_o °C.	T_{oc} 100
June 18							
1000-1100	0.886	0.076	0.753	0.462	0.348	41	20.24
1100-1200	0.976	0.074	0.698	0.531	0.370	46.5	21.48
1200-1300	0.897	0.062	0.761	0.476	0.359	50.0	22.32
1300-1400	0.587	0.075	0.819	0.282	0.230	49.8	22.11
1400-1500	0.499	0.065	0.954	0.221	0.212	41.1	22.32
1500-1600	0.418	0.039	0.783	0.212	0.166	40.7	22.12
1600-1700	0.281	-0.0004	0.930	0.146	0.135	39.6	21.87
1700-1800	0.076	-0.053	0.716	0.075	0.054	31.3	21.38
1800-1900	-0.060	-0.058	0.522	---	---	24.0	20.44
1900-2000	-0.134	-0.076	1.678	0.086	-0.144	18.4	16.04
2000-2100	-0.129	-0.066	3.886	0.022	-0.085	14.7	14.44
2100-2200	-0.125	-0.065	14.838	0.004	-0.064	13.1	13.99
2200-2300	-0.112	-0.053	2.887	0.031	-0.090	12.0	12.43
2300-2400	-0.076	-0.051	2.0	0.025	-0.050	12.1	---
June 19							
0000-0100	-0.074	-0.074	1.067	0.065	-0.65	13.5	14.03
0100-0200	-0.084	-0.063	1.251	0.084	-0.105	13.6	13.69
0200-0300	-0.102	-0.057	6.378	0.008	-0.053	11.8	11.79
0300-0400	-0.059	-0.028	4.909	0.008	-0.039	11.4	12.01

TABLE 5--Continued

emb 100	T ₁₀₀ - T ₃₃	e ₁₀₀ - e ₃₃	u ₁ M/sec.	u ₃₀ M/sec.	$\frac{u_{30M.}}{u_3 M.}$	dd	Cloud
11.93	-1.49	-1.27	---	---	---	--	---
11.67	-1.61	-1.43	---	---	---	SW	1 St
11.42	-2.11	-1.78	---	---	---	W	4 Ci, Cu
11.24	-1.66	-1.30	3.4	---	---	NW	5 Ci
11.07	-1.10	-0.74	5.7	---	---	NW	8 Ci
10.63	-1.05	-0.86	6.1	---	---	NW	6 Ci
11.08	-1.13	-0.78	8.2	---	---	NW	7 Ci
10.99	-0.17	-0.78	10.1	---	---	--	2 Ci
11.77	-0.26	-0.32	11.4	---	---	--	0 ---
13.26	+0.47	-0.13	1.3	---	---	--	0 ---
12.39	1.03	-0.17	1.6	---	---	--	0 ---
11.76	1.15	-0.05	1.5	---	---	--	0 ---
11.46	1.35	0.30	1.8	---	---	--	0 ---
---	---	---	1.1	---	---	--	7 Ci
12.31	0.55	-0.33	0.7	---	---	--	0 ---
12.68	0.41	-0.21	---	---	---	--	5 St
11.63	0.59	0.06	1.1	---	---	--	1 St
11.92	0.59	-0.07	0.6	---	---	NW	9 Ac

TABLE 6

HEAT BUDGET OVER UNIVERSITY OF WISCONSIN
MARSH FARM CORNFIELD

Time	$-R_{100}$	B_o	β_{33-100}	β_{11-33}	E_{100}	L_{100}	$T^{\circ}C_{100}$
May 28							
0430-0530	-0.057	---	-1.93	4.00	---	---	8.60
0530-0630	0.058	0.012	0.09	-0.46	0.085	-0.039	9.85
0630-0730	0.243	0.079	0.46	0.33	0.123	0.041	10.53
0730-0830	0.498	0.093	0.20	0.24	0.327	0.078	11.56
0830-0930	0.701	0.097	0.27	0.25	0.483	0.121	12.22
0930-1030	0.641	0.080	0.23	0.23	0.456	0.105	12.60
1030-1130	0.863	0.039	0.22	0.31	0.629	0.195	13.76
1130-1230	0.751	0.020	0.29	0.25	0.584	0.146	13.64
1230-1330	0.601	-0.001	0.23	0.30	0.463	0.139	13.37
1330-1430	0.583	-0.029	0.22	0.28	0.478	0.134	13.23
1430-1530	0.321	-0.050	0.19	0.35	0.274	0.096	12.26
1530-1630	0.318	-0.068	0.24	0.22	0.316	0.070	10.92
1815-1830	-0.011	-0.065	-0.18	0.21	0.045	0.009	9.79
1830-1930	-0.032	-0.075	-0.27	-0.50	0.086	-0.043	9.65
1930-2030	-0.047	-0.062	-0.35	-0.78	0.068	-0.053	9.11
2030-2130	-0.039	-0.058	-0.52	-0.49	0.037	-0.018	8.86
2130-2230	-0.048	-0.056	-0.45	-0.65	0.022	-0.015	8.51
2240-2335	-0.127	-0.088	-0.82	-2.50	0.026	-0.065	7.42
2341-0030	-0.121	-0.102	-1.82	-5.00	0.005	-0.024	6.19
May 29							
0030-0130	-0.126	-0.096	-3.30	-5.36	0.007	-0.037	5.18
0130-0230	-0.127	-0.073	-2.05	5.36	-0.009	-0.045	5.40
0230-0330	-0.123	-0.087	-3.20	11.32	-0.003	-0.033	4.47
0330-0430	-0.118	-0.068	5.04	4.24	-0.009	-0.041	3.05
0430-0530	-0.064	-0.025	---	2.30	-0.012	-0.027	4.88
0530-0630	0.119	0.046	0.26	-0.27	0.100	-0.027	7.68
0630-0730	0.344	0.077	0.40	0.61	0.166	0.101	9.53
0730-0830	0.633	0.130	0.37	0.66	0.304	0.199	12.75
0830-0930	0.819	0.186	0.40	0.58	0.400	0.233	14.12
0930-1030	0.941	0.244	---	0.74	0.400	0.297	15.19
1030-1130	0.017	0.227	0.61	0.90	0.415	0.374	17.08
1130-1200	1.053	0.197	0.65	0.77	0.483	0.372	17.67
1200-1300	1.025	0.142	0.80	0.93	0.457	0.425	18.22
1300-1400	0.993	0.086	0.73	0.88	0.482	0.424	19.09
1400-1500	0.594	-0.014	0.60	1.04	0.298	0.309	19.14
1500-1600	0.354	-0.066	0.60	0.78	0.235	0.184	18.63
1600-1700	0.200	-0.082	0.56	0.76	0.160	0.121	18.45
1700-1800	0.148	-0.101	0.58	3.87	0.051	-0.197	18.45
1800-1900	-0.032	-0.144	-0.01	-0.09	0.123	-0.011	16.46
1900-2000	-0.054	-0.085	-0.73	-0.23	0.040	-0.009	15.15

TABLE 6--Continued

emb 100	$T_{100} - T_{33}$	$e_{100} - e_{33}$	u_{30} M/sec.	u_1 M/sec.	$\frac{u_{30M.}}{u_3 M.}$	dd	Cloud
7.66	0.06	0.01	---	---	---	---	0
8.28	0.22	-0.30	---	---	---	---	---
8.00	-0.18	-0.36	---	---	---	---	---
7.92	-0.26	-0.71	6.2	2.8	---	WNW	Fc
8.22	-0.36	-0.92	6.9	3.8	---	WNW	1 Cu
8.46	-0.33	-0.92	6.9	3.8	---	WNW	2 Cu
9.43	-0.53	-1.11	7.0	4.6	---	WNW	7 Cu
9.00	-0.46	-1.18	7.6	4.9	---	WNW	7 Cu
8.81	-0.49	-1.04	8.1	5.4	---	WNW	9 Cu
8.75	-0.36	-0.81	6.7	4.8	---	WNW	3 Cu
8.16	-0.38	-0.71	6.6	5.5	---	NW	3 Cu
7.82	-0.23	-0.65	6.5	5.4	---	NW	9 Cu
7.86	-0.15	0.45	---	---	---	NW	4 Cu
7.24	0.20	-0.26	3.6	2.8	---	NNW	0
6.85	0.33	-0.28	3.4	3.2	---	NNW	9 Cu
6.71	0.22	-0.29	3.2	2.4	---	NW	10 Cu
6.94	0.21	-0.21	2.9	---	---	NW	10 Cu
6.24	0.25	-0.07	2.8	---	---	NW	10 Cu
6.26	0.45	-0.07	2.6	---	---	NNW	0
6.31	0.67	-0.08	---	2.4	---	W	0
6.43	0.67	0.08	---	2.8	---	W	0
6.40	0.85	0.05	---	2.7	---	WNW	0
6.27	0.85	0.12	---	2.2	---	W	0
6.90	0.36	0.13	---	2.7	---	W	0
7.90	0.05	-0.12	2.2	3.2	---	W	0
8.53	-0.43	-0.45	1.9	2.8	---	W	0
8.57	-0.61	-0.60	1.5	2.2	---	NW	0
8.03	-0.93	-1.03	---	3.7	---	---	0
---	-0.83	---	---	3.8	---	---	0
9.01	-1.08	-0.79	1.9	1.7	---	---	1 Ci
9.24	-1.17	-0.97	2.3	1.9	---	---	1 Ci, Cu
8.79	-1.28	-0.88	1.7	2.3	---	---	3 Ci, Cu
8.51	-1.59	-1.15	2.1	2.4	---	---	7 Ci, Cu
8.25	-1.45	-0.89	2.5	2.8	---	---	8 Ci, Cu
8.04	-1.12	-0.91	2.9	5.9	---	---	9 Ci
8.31	-0.61	-0.52	2.6	3.1	---	---	7 Ci
8.62	-0.29	-0.05	2.7	3.3	---	---	3 Ci
8.84	0.07	-0.49	1.7	2.3	---	---	3 Ci
9.44	0.13	-0.37	---	2.4	---	---	0

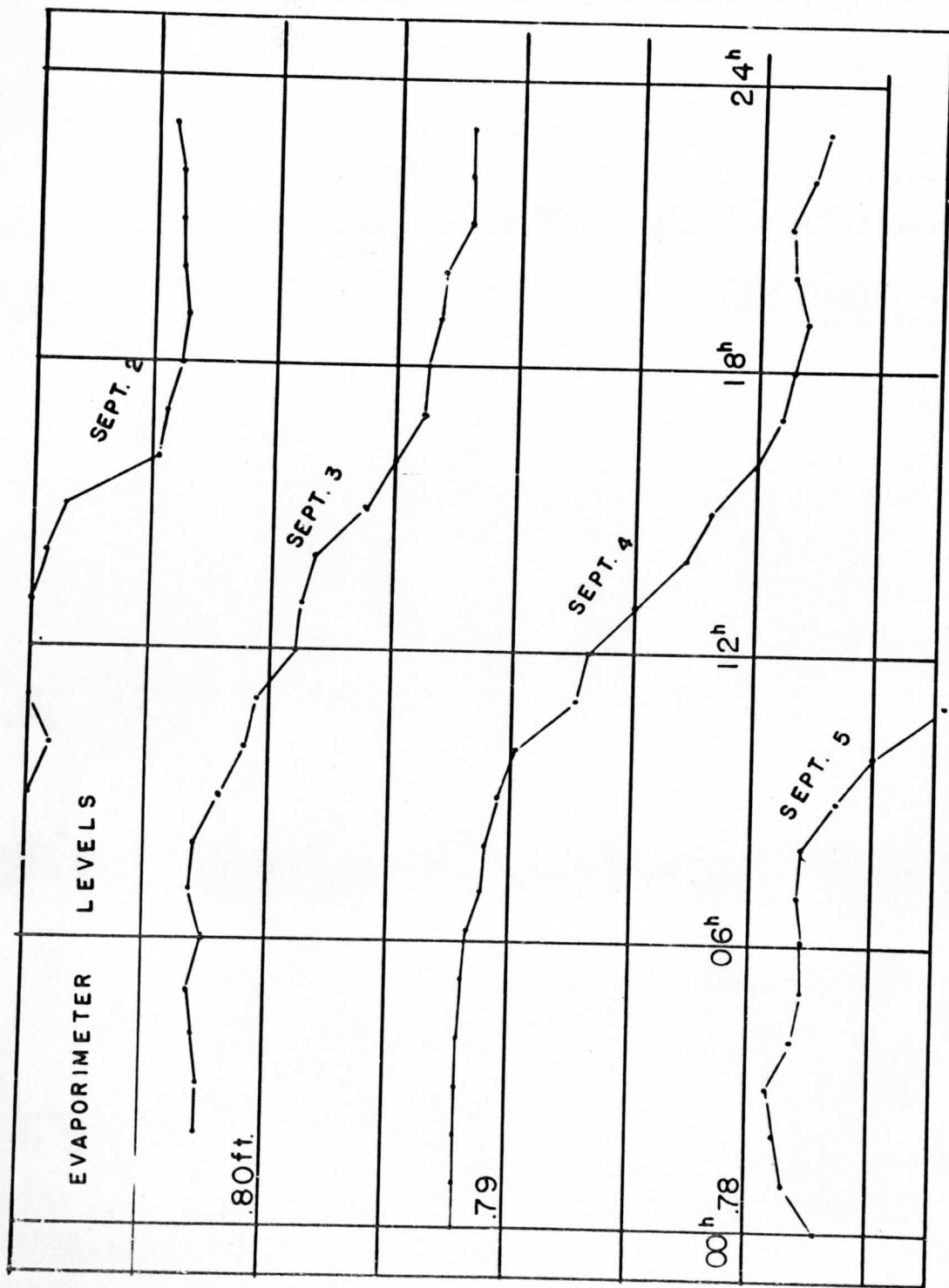

Figure 13

BIBLIOGRAPHY

- Albrecht, F. Meteor. Zeitschrift, 60 (1943).
- Bowen, I.S. Phys. Rev., 27 (1926).
- Deacon, E.L. Quart. J. r. meteor. Soc., 76 (1949).
- Geiger, R. Climate Near the Ground. Cambridge: Harvard University Press, 1950.
- Gerhardt and Crain. Electrical Engineering Res. Lab. Rept. 38, University of Texas, Austin.
- Gerhardt and Gordon. Jour. Meteor., 5 (1948).
- Lehman, P. Breiche d. Duet. Wetter. i. d. US a., 35 (1952).
- Lettau, H. Isotropic and Non-isotropic Turbulence in the Atmospheric Surface Layer. Air Force Cambridge Research Lab., 1949.
- _____. Trans. Amer. Geophys. Union, 32 (1949).
- Martinelli, et al. NACA Advance Res. Rept., 4H09 (Aug., 1944).
- Pasquill, F. Proc. Roy. Soc., 198, ser. A (1949).
- _____. Quart. J. r. meteor. Soc., 76 (1949).
- Rider and Robinson. Quart. J. r. meteor. Soc., 77 (1951).
- Schmidt, W. Prob. d. Kosm. Physik. Hamburg: H. Grand, 1925.
- Shannon, C.E. Proc. Inst. Radio Eng., 37 (1949).
- Spilhaus, A.F. Trans. Roy. Soc. So. Africa, 24 (1936).
- Suomi, et al. Sci. Rept. No. 1. Contract AF 19(122)-461. Dept. of Meteorology, University of Wisconsin, April, 1953.
- Sutton, C.G. Compendium of Meteorology. Boston: American Meteorology Society, 1951.
- Sverdrup, H.U. Oceanography for Meteorologists. New York: Prentice Hall, 1942.

Swinbank, W.C. Jour. Meteor., 8 (1951).

Vehrencamp, J.E. Trans. Amer. Geophys. Union, 34 (1953).

END

MICROFILMED BY
LIBRARY DEPARTMENT
OF
PHOTOGRAPHIC REPRODUCTION

UNIVERSITY OF CHICAGO

THESIS

NUMBER

1990

