

McIDAS

TRAINING MANUAL



**THE UNIVERSITY OF WISCONSIN - MADISON
SPACE SCIENCE AND ENGINEERING CENTER
1225 WEST DAYTON STREET
MADISON, WISCONSIN 53706**

M c I D A S

T R A I N I N G

M A N U A L

TABLE OF CONTENTS

Introduction. 1

Geostationary Satellite Imagery 4

Graphics. 6

Entering Commands 7

Single Letter Commands. 9

Loop Control System 11

 Image Looping. 11

 Graphics Looping 12

Image and Graphics Practice Session 13

Conventional Weather Data 19

Weather Analysis Practice Session 20

Pseudo Coloring 26

Pseudo Coloring Practice Session. 29

String Tables 34

String Table Practice Session 35

Data Tablet/Graphics Overlay. 37

Graphics Overlay Practice Session 38

McIDAS Operations Procedures and Policies 43

Glossary. 45

INTRODUCTION

The Man-computer Interactive Data Access System (McIDAS) was developed at the Space Science and Engineering Center at the University of Wisconsin-Madison. During the 1970's, McIDAS evolved from a single minicomputer with two video terminals, mainly used as a research tool, to a network of eight minicomputers used for research and also for the First GARP Global Experiment (FGGE) operational support. The current McIDAS system consists of a mainframe IBM computer with more than fifteen local and remote terminals, extensively used both for research and operations (See Fig. 1).

McIDAS is unique because of its capability to ingest real-time geostationary weather satellite data and conventional weather data, and also for its ability to easily access and interactively analyze this large quantity of data. For example, with McIDAS you can:

- view a time sequence of satellite images
- color enhance the digital data or pass it through a filter
- overlay surface and upper air temperature or vorticity contours on the imagery
- calculate stability parameters
- display a hodograph or thermodynamic diagram.

Weather parameters may be displayed in either cartesian or isentropic coordinates. Extensive software is available for processing satellite sounding data, tracking cloud motions, or generating statistics of specified geographic areas of a digital image.

McIDAS does not have a menu to follow, so the choice of commands, input via the keyboard, is completely up to the user, making the system extremely flexible. As an alternative, a data tablet is available which allows the user to enter commands by pressing a pen onto preprogrammed areas of the tablet. The data tablet is especially useful operationally where a limited number of commands are used repeatedly.

The training material that follows is designed for a user who has no previous knowledge of digital imagery manipulation or display using an interactive computer like McIDAS. Each section commences with a general description of the type of data (i.e., satellite imagery) or type of function (i.e., pseudo coloring) being presented, along with commonly used terminology. Since "hands on" experience is the best way to learn, most sections include a practice session where the user can follow along step-by-step, entering given commands and observing the response of the alphanumeric and video display monitors.

Preceding the first practice session are basic discussions on how to enter commands from the terminal keyboard and definitions of commands used for terminal manipulation. Explanations on general McIDAS policies and a glossary of terms can be found at the end of the manual. Work through the manual in order from the beginning. Later practice sessions use some tools that you learn in earlier sections (i.e., loading a current satellite image).

Of course it is not possible nor practical to cover all available commands or all options of a single command within this training manual. Further details can be found in the McIDAS Users' Manual.

08/D1/16

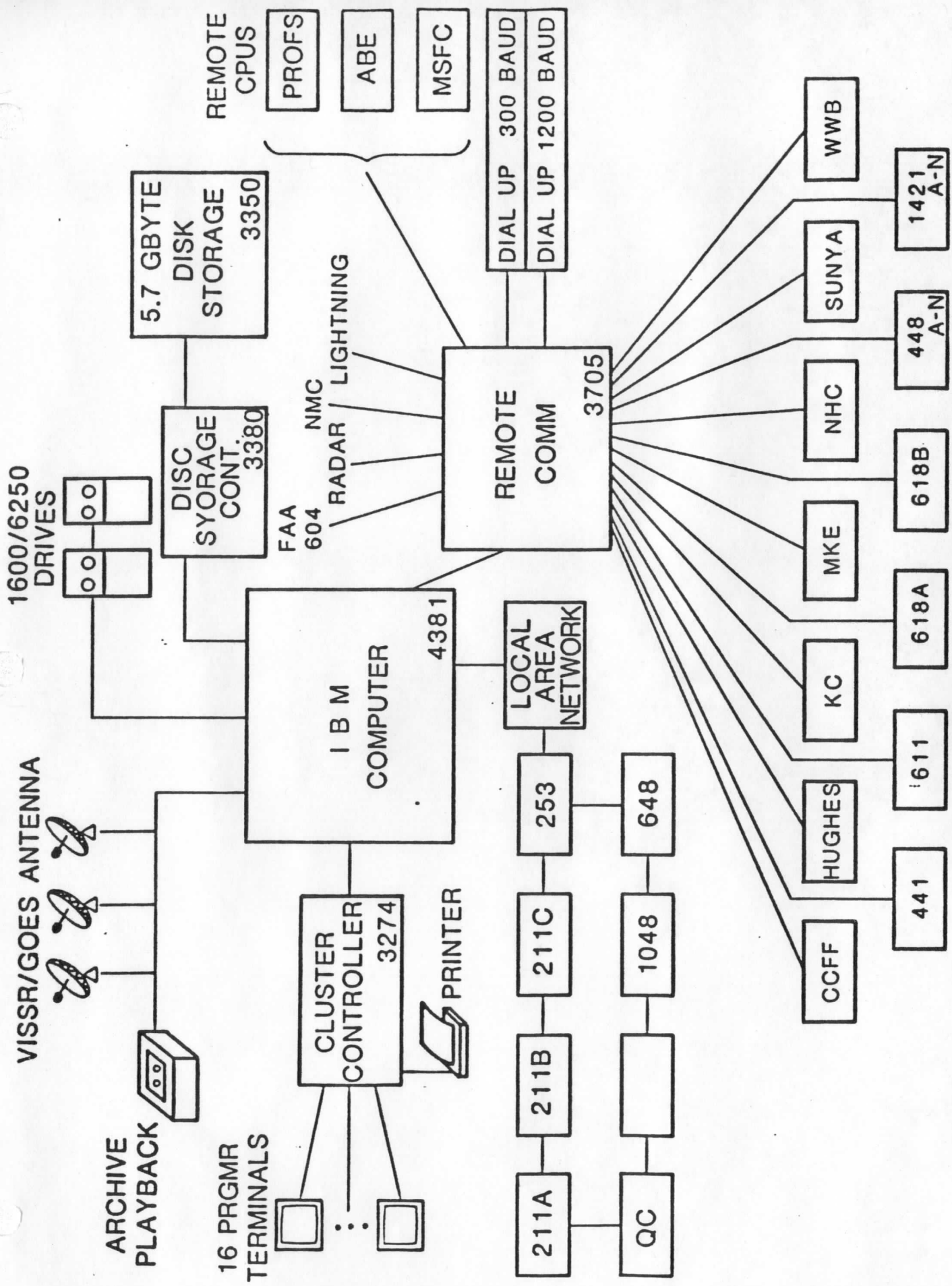

Fig. 1. Schematic diagram of the current McIDAS configuration, including hardware devices, local and remote terminals.

GEOSTATIONARY SATELLITE IMAGERY

Geostationary satellites are positioned over the equator, rotating with the earth, thus always viewing the same location. Visible images are obtained by sensing reflected sunlight, while infrared (IR) images are obtained by sensing emitted longwave radiation in the infrared spectral region. The digitized image brightnesses are stored in the McIDAS computer on digital disc files called areas. Every digital image consists of horizontal lines, numbered from top to bottom, each containing a sequence of elements or pixels, numbered from left to right. Consequently, each pixel is assigned a unique pair of integers, line, element (LINE, ELEM), referred to as the image coordinates of the pixel.

Satellite imagery is not very useful unless the earth locations of interesting features are known. This requires knowledge of the satellite's orbit, which is not perfect, but varies with time. Navigation is the process of determining a set of variables describing the position of the satellite and using them as input to an algorithm which provides transformations between the earth coordinate system and the satellite coordinate system. As a result, the line and element of each image pixel can be transformed into a latitude and longitude.

To make images visible on the video monitor, they are transferred from disc to a storage device called a TV refresh memory which is divided into image frames. Conceptually, frames can be thought of as a sequence of pictures on a film strip. One image frame may contain only one satellite image, and only one image frame can appear on the video monitor at one time. When consecutive image frames are loaded with a chronological series of satellite images, they can be viewed sequentially (looped) to follow cloud motions.

The imagery is displayed in shades of gray, with the brightness proportional to the digital data. The digital information cannot be accessed from the refresh memory, so the data must also remain in the area. Since a video monitor frame can only hold 480 lines by 640 elements, a subset of the original image, which may be several thousand lines long and several thousand elements wide, is usually chosen for display. When loaded onto an image frame, each pixel is referenced by a TV line, TV element pair (TVLINE, TVELEM), with (1,1) in the upper left hand corner and (480,640) in the lower right hand corner. The number of frames available is terminal dependent. The first half of the total number of frames is considered as current frames, while the second half is considered opposites. This allows easy comparison of two images, such as visible and infrared.

The resolution of a visible image pixel is 1 km at the subsatellite point, while the resolution of an IR pixel is 4 km at the subsatellite

point. Disc space considerations do not permit saving 1 km images of the entire globe on disc; thus, current GOES images saved on disc are:

- USA visible at a resolution of 1 km
- global visible at a resolution of 4 km
- global IR at a resolution of 4 km.

The visible image "blowdown" to 4 km resolution is accomplished by sampling every fourth element and every fourth line of the original image. An image may also be magnified to see a closeup of a particular feature. For example, a "blowup" of 4 will cause each pixel to be repeated 16 times (2^4), with a resulting resolution written as 0.25. While this gives the impression of increased resolution, it does not increase the amount of information.

Current GOES East and GOES West visible and infrared images are contained in digital areas 101 to 120. A 24-hour digital archive of VISSR (Visible Infrared Spin Scan Radiometer) imagery from both east and west GOES satellites has been maintained since 1978 on high density digital video cassettes. History data may be ingested directly into the system from the archive or via two 9-track tape drives.

A practice session for displaying satellite imagery begins on page 13.

08/D1/09

GRAPHICS

Graphics refers to line drawings such as maps, isolines, or text displayed using a number of graphics overlay memories called the Write Random Read Rastor Memory (WRRRM), which is separate from the image memory. Each terminal is provided with half as many graphics frames as there are image frames. Similar to an image frame, only one graphics frame can be displayed on the video monitor at one time. Each graphics frame is 480 x 640 pixels, with 3 bits per pixel, usually capable of displaying 8 levels or colors. The total number of graphics frames is terminal dependent.

Graphics are displayed in the TV coordinate system of TV lines and elements. Map outlines and contouring can be drawn in any of four projections:

- satellite
- mercator
- polar stereographic
- Lambert conformal.

If a satellite projection is used, the TVLINE,TVELEM coordinate system can be translated into LINE,ELEM and LATITUDE,LONGITUDE coordinates. When image and graphics frames are displayed together, the graphics frame appears to overlay the image frame (i.e., GOES East satellite image with state boundaries).

Examples of types of graphics include:

- a Midwest map of state outlines
- a plot of surface temperatures over the eastern USA
- a label to identify an underlying satellite image
- a graph of brightnesses along an image line
- a skewt or stuve diagram.

Graphics frames can be turned on and off and looped in the same manner as image frames. However, they are only for temporary storage, and may be erased by another user after logging off of the terminal. A very limited number of graphics can be saved by routing the output to a line printer. The alternative save would be to photograph the graphics using 35 mm slides. A hard copy device can be attached to the TV monitor to yield black and white reproductions of images or graphics.

A practice session for basic graphic manipulations begins on page 13.

08/D1/09-2

ENTERING COMMANDS

To begin a McIDAS terminal session, type the line feed key, enter your 3 initials and your 4 digit project number, followed by a carriage return (i.e., *<line feed> NNN 9999 <carriage return>*). Your terminal will remain in its current state. If you follow your initials with the letter I, your terminal will be initialized to a basic state by setting loop bounds, setting default files, clearing the string table, etc., as defined in the file DALOGON. If you follow your initials with the name of a string table, the terminal will be initialized to the basic state and then the specified string table will be loaded and executed. For more details look at the file DALOGON by typing *SHOWME DALOGON*. To terminate a McIDAS session, type in *LOGOFF*.

Two basic command formats are used within the McIDAS system:

- Single letter commands -- these have no parameters.
- Multiple letter commands -- these may have 0-64 parameters which may be positional parameters and/or keyword-value pairs. (Keyword=value counts as 2 parameters.)

To enter a single letter command, simply type the letter on the keyboard without a line feed or carriage return. The system does not echo the one letter commands on the CRT, and if the computer is busy, the desired action may occur after a delay. To enter a multiple letter command, type a line feed key, enter the command followed by the necessary parameters (if any), and then type a carriage return. This input string is echoed by the system on your CRT.

Most commands do not require you to enter every possible parameter, but instead have default values for many of them. The parameters and the values for their defaults can be found by typing *HELP <program name>* (i.e., *HELP LA*) or by looking up the program name in the McIDAS User's Manual. Some commands in the manual are known as macros. Macros combine a sequence of executable steps into one command, saving the user from having to type in each step separately.

When entering commands, certain conventions must be followed when specifying satellite/year/day, time, or latitude/longitude. These conventions can be found on page 4 of the McIDAS Manual Introduction. Another point to note: west longitudes are positive.

If a mistake is made when typing a line, you may delete the line with the DEL or SHIFT RUB keys (depending on your CRT model), and start over with a line feed. The individual character pointer on the CRT can be back-spaced for single character changes, using the CONTROL H key, then retyping the character.

A general feature of the McIDAS command structure is that all commands are executed asynchronously. That is, the system does not execute commands in the order in which they are typed, but rather in the order in which system resources (i.e., core space) become available. The system typically has 15 initiators or 15 separate tasks that can execute simultaneously. It is not necessary to wait until one command has completed execution before

another is typed in. You may enter several commands to the system; however, only 3 initiators can be used by a single terminal at any one time. If one command requires the output from a previous command, you should be sure the first command has completed execution before the second is entered. If the computer is very busy, the execution of commands may take several minutes.

To check the current status of the system, type either an *SS* or simply a *SHIFT ?*. This lists the initiators currently in use and the programs executing in each initiator. If you want to terminate a program that is in the process of executing:

- Check the system status (*SHIFT?*)
- Find the initiator number in which your program is executing.
- Type a linefeed, / (initiator #), carriage return to terminate the program.

You will get the following response on your CRT:

```
$INIT # RESTARTED U002.
```

If you have any problems with your terminal or if you see the message *COMMUNICATIONS TIMEOUT* on your terminal (indicating that it is down), contact the computer operators. To contact the operators, call (608) 262-0502 or send a terminal message using command, *WTOR*.

In general, to communicate with other terminals use command, *MAIL*.

08/D1/09-4

SINGLE LETTER COMMANDS

These commands, once struck, execute a program without being preceded by a LINE-FEED, and without being followed by a CARRIAGE RETURN.

- A - Advance one video frame.
- B - Back up one video frame.
- C - Lists, on the CRT, the documentation (i.e. date, time, magnification) of the currently displayed video frame.
- D - Lists, on the CRT, the brightness (VISIBLE) or the brightness and temperature (IR) at the cursor's center pixel of the currently displayed video image.
- E - Lists, on the CRT, the earth coordinates, in degrees latitude and longitude, the image line and element, and the TV line and element, at the cursor's center pixel, of the currently displayed video image.
- F - Lists, on the CRT, the current image and graphics frame numbers and status, the loop bounds, and the cursor status.
- I - Lists, on the CRT, the image coordinates, in lines and elements, and the TV coordinates, at the cursor's center pixel, of the currently displayed video image.
- J - Locks and unlocks the ability to advance graphics frames.
- K - Toggles (i.e., turns on and off) the displayed video image. If the TV screen is black, strike the key to restore it. This does not tamper with the digital area.
- L - Starts and stops looping (stepping through) the video image and/or graphics frames. See "J" and "Y" for control of images and graphics.
- N - Toggle for the pictel interlace of the currently displayed image and its opposite. Try this key if the image has coloring that you did not request.
- O - Displays the opposite frame of the currently displayed frame.
- P - Locks and unlocks the joystick/cursor control.
- R - Multi purpose command.*
- T - Lists, on the CRT, the TV coordinates, in raster and pictels, at the cursor's center point, of the currently displayed video image.
- U - Lists, on the CRT, the Julian day, the date, the time, the users initials, and the 4-digit project number.
- V - Locks and unlocks joystick control of the velocity cursor (left hand joystick). While in the velocity mode the cursor will "jump" with each advancement of a video frame.

W - Toggles the graphics WRRRM display. This will blank and restore the graphics. The graphics will not be erased so be careful with your next graphics command.

Y - Locks and unlocks the ability to advance video frames.

Z - Locks and unlocks joystick control of the cursor size (lefthand joystick).

0 thru 9 - User defined with the "TE" command. This is a shorthand for two-letter commands.

? - Lists, on the CRT, the current system status.

Space bar - Multipurpose command.*

. - Multipurpose command.*

; - Multipurpose command.*

> - Pages forward text. Used in conjunction with programs HELP and SHOWME.

< - Pages backward text. Used in conjunction with programs HELP and SHOWME.

(* usually program dependent. See McIDAS User's Manual for explanations.)

08/DR1/06

LOOP CONTROL SYSTEM

P.1 - The loop control system refers to a group of McIDAS commands developed to manipulate terminal hardware, allowing you to step through consecutive graphics frames or image frames. Upon logging onto a terminal, using the 'I' option, the loop control system is initialized, and the total number of available image and graphics frames is listed on the CRT. When the loop control system is initialized, the beginning frame number is set to 1 and the ending frame number is set to half of the total number of frames. In other words, a terminal with 20 image frames would have loop bounds beginning on frame 1 and ending on frame 10. A terminal with 8 graphics frames would set the loop bounds beginning on graphics frame 1 and ending on graphics frame 4. In these examples, image frames 11 through 20 and graphics frames 5 through 8 are referred to as "opposites".

Image and graphics frame numbers are located on the lower left-hand corner of the TV screen. Image frame numbers are gray; graphics frame numbers are usually yellow, located to the left of the image frame number. Image frame and graphics frame looping, or stepping through frames, can be done simultaneously or independently.

IMAGE LOOPING

The following commands apply to looping and toggling (i.e., turning on and off) image frames. A line feed is not needed prior to entering a single letter command.

Single letter commands: A, B, F, K, L, O, and Y.

- A = Advance one frame
- B = Backup one frame
- F = List status of the frames on the CRT
- K = Turn image on or off
- L = Automatic looping; turns looping on or off
- O = Display opposite frame
- Y = Lock or unlock image frames. When locked, frames will not move.

Multiple letter commands require a line feed before entering the command and a carriage return following the command.

Multiple letter commands: DR, LB, and SF.

Command Format:

- DR dwell rate
- DR framel...frame12
- LB IMA lower upper OR LB lower upper
- SF frame number

The dwell rate is the time spent on each frame in 1/15 of a second. This applies to automatic looping (L). When only one rate is input, the same amount of time is spent on each frame. To vary the dwell time for different frames, separate rates may be defined for up to 12 frames. All frames in the loop after the 12th frame are assigned the same dwell rate as the 12th frame.

LB sets the image frame loop bounds. In other words, the beginning and end of the loop is defined. As a result, the corresponding opposite frame loop bounds are also set. To access an image frame outside of the loop bounds, use *SF* <frame #>, which will display the image frame requested. To return to the loop bounds, type *L*. During automatic looping, when the end of the loop is reached, the system resets to the first frame in the loop.

GRAPHICS LOOPING

The following commands apply to looping and toggling graphics frames. Single letter commands: A, B, F, J, L, O, and W.

A, B, F, L, and O are defined under image looping.

J = Lock or unlock graphics frames. When locked, frames will not move.

W = Turn graphics on or off.

Two letter commands: DR, LB, SG, and EG.

Command format:

DR dwell rate (is dependent on image frames)

LB GRA lower upper

SG frame number

EG frame number OR EG

A, B, L, and O work the same with graphics frames as they do with image frames. To access a graphics frame outside of the loop bounds, use *SG*. To return to the loop bounds, use *L*. The dwell rates of graphics frames equal the dwell rates of the corresponding image frames. When changing the graphics frame dwell rates using *DR*, the image frame dwell rates also change. *EG* will erase the graphics frame, unlike *W* which just temporarily turns the graphics off.

08/D1/09-6

IMAGE AND GRAPHICS PRACTICE SESSION

The following practice session will familiarize you with the commands necessary to load and view geostationary satellite imagery. The last two pages of this session cover basic graphics commands. Type the commands on the keyboard and observe the response of the CRT. Both commands and responses are written in capital letters. The satellite images will appear on the TV monitor.

Before starting this session, please read the discussions on geostationary satellite imagery and graphics. Certain commands in this practice session (like LA or OD L) will not produce exactly the same CRT response as written here because you will be working with data from a different date with a different weather situation. Remember to type a line feed prior to entering any multiple letter commands, and then follow the command with a carriage return.

<u>COMMAND</u>	<u>CRT RESPONSE</u>
1. Log on: Type a line feed, your 3 initials, 4 digit project number, and the letter I, followed by carriage return. This starts your terminal session and initializes your terminal.	IMAGE BOUNDS: 1 2 3 4 DWELL RATES: 9 6 6 6 DR FINISHED T=44 1048 TYP=VID REM NLIN=488 640 NFRM=8 4 message of the day +LOGON COMPLETE+
2. LA 101 120 will list all current GOES East and West digital areas available on the IBM.	(See Fig. 2)
3. SF 1 Sets the image frame to frame 1.	NONE
4. SG 1 Sets the graphics frame to frame 1.	NONE
The image and graphics frame numbers are both on the bottom left of your video screen with the image frame number to the right of the graphics frame number.	
5. EG Erases the current graphic.	ERASED GRAPHICS FRAME 1

Under normal operation, GOES East and West images are available every half hour. For storm coverage on certain days, images are available every 15 minutes. For research purposes, on selected storm days the satellite is in rapid scan mode, obtaining limited area images over the United States every 3 or 5 minutes.

When you load the images below, please keep in mind that during regular half hour operation you must wait at least six minutes after the image time to be sure that the image over the United States has been ingested. If you load a new image earlier than this, part of it will probably be black.

08/D1/09-7

Fig. 2. Listing of digital areas 101 to 120 containing real time geostationary satellite imagery for May 31, 1984 from 1401 GMT to 1545 GMT.

AREA	SS	YYDDD	HHMMSS	LCOR	ECOR	LRES	ERES	ZRES	LSIZ	ESIZ	ZSIZ	BANDS
101	28	84152	143600	2132	2638	1	1	0	4958	5948	1	NA
102	28	84152	150100	2126	2638	1	1	0	4958	5948	1	NA
103	28	84152	153100	2126	2638	1	1	0	4958	5948	1	NA
104	28	84152	140100	2144	2637	1	1	0	4958	5948	1	NA
105	28	84152	150100	801	1	4	4	0	3400	3800	1	NA
106	28	84152	153100	801	1	4	4	0	3400	3800	1	NA
107	28	84152	140100	801	1	4	4	0	3400	3800	1	NA
108	28	84152	143600	801	1	4	4	0	3400	3800	1	NA
109	29	84152	153100	801	1	4	4	0	3400	3800	18.....
110	29	84152	140100	801	1	4	4	0	3400	3800	18.....
111	29	84152	143600	801	1	4	4	0	3400	3800	18.....
112	29	84152	150100	801	1	4	4	0	3400	3800	18.....
115	30	84152	154500	101	1	4	4	0	3400	3800	1	NA
116	30	84152	154500	101	1	4	4	0	3400	3800	1	NA
117	31	84152	154500	101	1	4	4	0	3400	3800	18.....
118	31	84152	154500	101	1	4	4	0	3400	3800	18.....
119	30	84152	154500	2010	7923	1	1	0	1800	2300	1	NA
120	30	84152	154500	2010	7923	1	1	0	1800	2300	1	NA

---LA DONE

Definition of headings:

- AREA area number on disc containing the digital image
- SS satellite sensor source code (i.e., 28 is GOES East visible)
- YYDDD year (YY) and Julian day (DDD)
- HHMMSS time in hours (HH), minutes (MM), and seconds (SS)
- LCOR,ECOR the line and element coordinates of the upper left hand corner of the image
- LRES,ERES,ZRES the line, element, and vertical resolution of the image, in kilometers
- LSIZ,ESIZ the number of lines and elements in the digital area
- BANDS spectral band through which the image is sensed (NA - not applicable -- for visible images)

08/D1/13

Find the 3 most recent visible images in areas 105-108 and load them chronologically using the following commands. (For this session, they are assumed to be in areas 107, 108, and 105, in that order. You should change these area numbers if necessary.)

<u>COMMAND</u>	<u>CRT RESPONSE</u>
6. DF 107 1 EC 38 90 Loads area 107 into image frame 1 using earth coordinates to center the image at latitude 38N and longitude 90W.	BEGIN TV LOAD 1 FRAME ADDED TO OUTPUT QUE 1 DF FRAME DONE 1
7. DF 108 2 EC 38 90 same as #6 to load area 108 into image frame 2.	BEGIN TV LOAD 2 FRAME ADDED TO OUTPUT QUE 2 DF FRAME DONE 2
8. DF 105 3 EC 38 90 same as #6 to load area 105 into image frame 3.	BEGIN TV LOAD 3 FRAME ADDED TO OUTPUT QUE 3 DF FRAME DONE 3

Now find the 3 most recent infrared images in areas 109 to 112, whose times correspond to the 3 visible images loaded above. (Areas 111, 112, and 109 are used here, and should be changed if necessary.) When on frame 1, strike the *F* key (without a line feed). This lists frame information on the CRT such as the current frame number and the opposite frame number. Begin loading the IR images on the opposite frames, assumed here to be 5, 6, and 7. Remember, the number of your opposite frames may not be the same as used here because different terminals do not necessarily have the same number of image and graphics frames due to their design. For example, if your terminal has 32 image frames, your opposite frames range from 17 to 32.

9. DF 111 5 EC 38 90 Loads area 111 into image frame 5 using earth coordinates to center the image at latitude 38N and longitude 90W.	BEGIN TV LOAD 5 FRAME ADDED TO OUTPUT QUE 5 DF FRAME DONE 5
10. DF 112 6 EC 38 90 Same as #9 to load area 112 into image frame 6.	BEGIN TV LOAD 6 FRAME ADDED TO OUTPUT QUE 6 DF FRAME DONE 6
11. DF 109 7 EC 38 90 Same as #9 to load area 109 into image frame 7.	BEGIN TV LOAD 7 FRAME ADDED TO OUTPUT QUE 7 DF FRAME DONE 7

Please wait for images to finish loading before proceeding.

12. PC LOC MSN Places cursor over Madison, Wisconsin.	LAT/LONG POSITION= 43:07:48 89:19:48 CURSOR POSITIONED
---	---

COMMANDCRT RESPONSE

- | | |
|--|---|
| 13. PC C
Places cursor at center of image frame. | CURSOR POSITIONED |
| 14. Strike the <i>E</i> key.
Lists location information of the cursor center. | LATITUDE LONGITUDE LINE ELEM
37:59:47 90:01:30 2989 5985
TVLINE TVELEM
244 320 |
| 15. Strike the <i>D</i> key.
Lists digital value of image pixel at cursor center. | DATA: 191 |
| 16. Hit <i>O</i> to get to the IR image, then hit <i>D</i> again. Lists digital value and black body temperature of the image pixel at the cursor center. Hit <i>O</i> again to return to VIS image. | DATA: 197 TEMP: 2210 |
| CUR 15 15 1
Changes cursor size to 15 pixels high and 15 pixels wide, and changes cursor type to a box. | CURSOR SELECTION COMPLETED |
| 17. OD L
Lists brightness counts within cursor. | YYDDD= 84143
HHMMSS= 150000
<digital counts> |
| 18. IC H
Plots a high resolution map of the state outlines on the graphics frame in a satellite projection. | IC SEARCH OF MAP FILE OUTLUSA
IC DONE |

Please read the discussion on loop control, then continue with the practice session:

While on frame 1, try a few of the single letter commands (no line feed) like *O* to display the opposite frame, *K* to turn off the image, *W* to turn off the graphics, and *F* to give you the current frame status. Strike *W* and *K* again to turn the graphics and image back on, and then hit *O* again to return to frame 1.

- | | |
|--|---|
| 19. LB 1 3
Sets the image loop bounds from frame 1 to frame 3. | IMAGE LOOP BOUNDS: 1 3
GRAPHIC LOOP BOUNDS: 1 4
LB FINISHED |
| 20. Strike an <i>F</i> key. In the right-most column, if the graphics frame is listed as locked, then go on to step 21. If the graphics frame is listed as connected, then strike a <i>J</i> key to freeze the graphics frame. If you now strike an <i>F</i> key again, the graphics frame should be listed as locked. | NONE |

COMMANDCRT RESPONSE

- | | |
|---|--|
| 21. Strike the <i>A</i> key to step through the image loop. Hitting the <i>A</i> key while on frame 3 will return you back to frame 1. (If the frames do not advance, strike the <i>Y</i> key to unlock the image frames.)
Strike the <i>B</i> key to step backwards through the loop. | NONE |
| 22. Strike the <i>L</i> key once to advance the frames automatically.
Strike <i>L</i> again to stop looping. | NONE |
| 23. Strike <i>L</i> again to start looping.
DR 2
Sets the dwell rate for 2/15 seconds per frame. | NONE
IMAGE BOUNDS: 1 2 3
DWELL RATES: 2 2 2
DR FINISHED |
| 24. DR 8
Sets the dwell rate for 8/15 seconds per frame. | IMAGE BOUNDS: 1 2 3
DWELL RATES: 8 8 8
DR FINISHED |
| 25. DR 2 6 10
Dwell rate is:
2/15 sec on first frame
6/15 sec on second frame
10/15 sec on third frame | IMAGE BOUNDS: 1 2 3
DWELL RATES: 2 6 10
DR FINISHED |
| 26. Striking <i>O</i> now will loop the opposite images at the same rate. | NONE |

To loop the graphics frames alone, lock the image frames with a *Y* key and unlock the graphics frame with a *J* key. Images and graphics can be looped together by unlocking both.

The commands that follow deal solely with the graphics frames.

- | | |
|---|---|
| 27. SG 2
Sets graphics frame to 2. | NONE |
| 28. EG
Erases the current graphic. | ERASED GRAPHICS FRAME 2 |
| 29. GD 2
Sets graphics line width to 2 pixels (usually = 1). | DEFAULT GRAPHICS LINE WIDTH=2 |
| 30. IC L
Plots a low resolution map of the state outlines in a satellite projection. | IC SEARCH OF MAP FILE OUTLWRLD
IC DONE |

COMMAND	CRT RESPONSE
31. CUR 40 50 Makes the cursor 40 pixels high and 50 pixels wide. Hit a P key to unlock the cursor so it can be moved around.	CURSOR SELECTION COMPLETED
Move the cursor over a line on the map and type CW. Any graphics within the cursor will be erased.	NONE
32. CW 3 Fills the cursor in with color level 3 (usually yellow).	NONE
33. CS 3 RED Changes color level 3 to red. The box filled in in #26 should turn red. (Note: Due to the hardware configuration of some terminals, the color may not change to red.)	COLOR SELECTION COMPLETED
34. Move the cursor to an empty area. ZA 3 10 "USA The letters USA will be written horizontally on the graphics frame in color level 3, 10 pixels high, starting at the cursor center.	NONE
35. ZL 2 Starts the cursor line drawing program. Move the cursor and hit the spacebar to draw line segments. Hit . to end. (Note: It is important that you remember to end this program with a period (.); otherwise, it will continue to execute.)	HIT SPACE TO DRAW, HIT . TO EXIT ZL DONE
36. LOGOFF To log off the system.	NONE

See Chapter 5 of the McIDAS User's Manual for more details on graphics. See Chapters 2 and 3 for image and frame manipulation commands.

08/D1/09/7-10

CONVENTIONAL WEATHER DATA

McIDAS not only receives real time satellite imagery, but also ingests meteorological data such as FAA Service A hourly weather data, Service C radiosonde observations, ship observations from oceans and lakes, radar data, NMC forecast guidance, and weather advisories (to name a few) through dedicated and dial-up communications lines. The most recent 4 days of:

- hourly surface data
- RAOB data
- ship data

are always available on the system stored on disk in what are called meteorological data files (MD files).

Conceptually, an MD file may be thought of as a large two-dimensional table of data records. One record may contain several pieces of information, such as temperature, dew point, wind, pressure, etc. Each data record makes up one observation and can be accessed by a row, column number pair. When appropriate, a single row contains all data for a particular time, while a single column contains data for one geographic location.

In order to display contours of surface or upper air data, it must first be interpolated from the MD file to a uniform grid. The grid is a geographic lattice in either a pseudo mercator or conformal projection with gridpoints spaced the same number of degrees in both latitude and longitude. One grid file on the IBM/McIDAS can contain up to 159 grids.

By accessing data directly from MD files you can:

- plot meteorological parameters
- generate isentropic surfaces or stability parameters
- display soundings or cross sections
- display cloud winds.

In addition, by utilizing grid files you can:

- contour meteorological parameters
- compute derived parameters such as vorticity or divergence
- contour isentropic or stability parameters
- display radar data.

The data can also be listed on the CRT or printer, or displayed on the video monitor with and without underlying satellite imagery.

A practice session for weather analysis begins on page 20.

08/D1/09-3

WEATHER ANALYSIS PRACTICE SESSION

The following practice session will give you a sample of the variety of weather analysis displays available. Please read the section on conventional weather data before starting this session.

COMMAND

CRT RESPONSE

Load a current visible GOES East satellite image, with a resolution of 4 km, onto Image Frame 1: i.e., list the images using LA, look in the LRES and ERES column for 4 km resolution, then load the image using DF <area> 1 EC 38 90.

- | | | |
|---|--|-----|
| 1. TD ALL
Deletes the current string table.
SG 1
Shows graphics frame 1
EG
Erases graphics frame 1.
IC H
Draws a map of state outlines
on the graphics frame. | TD STRING TABLE CLEARED

ERASED GRAPHICS FRAME 1
IC SEARCH OF MAP FILE OUTLUSA
IC DONE | 705 |
| 2. SP T SAT
Plots current surface temperatures
(°C) over the satellite image. | ---PLOTING DONE | |
| 3. EG
IC H

SP PLOT SAT
Plots surface parameters in the
form of a station model. | ERASED GRAPHICS FRAME 1
IC SEARCH OF MAP FILE OUTLUSA
IC DONE
---PLOTING DONE | |
| 4. EG ; IC H
You can string commands together
on one line like this as long
as they are separated by a semicolon.

SC T SAT
Grids surface temperatures and
files them into the terminal's
default grid file. Then tempera-
ture contours are drawn on the
graphics frame. | FILE 44 GRID 1
--BEGIN CONTOURS
--END CONTOURS | |
| <p><u>Note:</u> The default grid file on all terminals is equal to the terminal number (which is 44 in the examples shown here)</p> | | |
| 5. EG ; IC H
UC VOR 500 SAT
Grids and contours 500 mb
relative vorticity in the
satellite projection. The
resulting grid is placed into
Grid 4 of Grid File 44. | GRID FILE: 44**
RESULTS INTO GRID# 4
--BEGIN CONTOURS
--END CONTOURS | ** |

COMMANDCRT RESPONSE

6. IGG LIS

```

GRID FILE:      44**
# YYDDD HHMMSS NAME  LEVEL SRC  VT  NR  NC  LLNW  INC
-----
1 84186 140000 T    SFC   MDX  0  25  36  52/ 113 1.0000
2 84186 120000 U    500  MB MDX  0  25  36  52/ 113 1.0000
3 84186 120000 V    500  MB MDX  0  25  36  52/ 113 1.0000
4 84186 120000 VOR  500  MB MDX  0  25  36  52/ 113 1.0000
---END OF LISTING

```

Lists grids in the current Grid File 44. Notice that grids U and V were created before VOR could be calculated. Of course, your date and times will differ from those listed above, depending on when you enter the commands.

7. EG ; IC H
UP IDN 500 SAT
Plots 5-digit RAOB station identifiers. --PLOTTING DONE
8. SG 2
Shows graphics frame 2.
EG ERASED GRAPHICS FRAME 2
Erases graphics frame 2.
Also hit a K key to turn off the satellite image.
9. Using one of the RAOB identifiers on Graphics Frame 1 (We chose 72645 for Green Bay):
SKEWT 72645 12 COMPLETED
Plots a SKEW-T thermodynamic diagram for Green Bay at 12 GMT.
10. EG ERASED GRAPHICS FRAME 2
HODO 72645 12 HODOGRAM PLOTTER V1
Plots a hodograph for Green Bay at 12 GMT.
11. EG ERASED GRAPHICS FRAME 2
MG MKC SVC METEORGRAM V1
Plots a meteorogram for Kansas City.
12. EG ERASED GRAPHICS FRAME 2
Hit K key to turn image back on.

Current (i.e., today and the previous three days) surface, RAOB, and ship data are found in MD files 1 to 40. If today's Julian Day is 186, then you use the last digit, 6, as an index to the MD files. You can find the current Julian day by typing a U. For example, for day 186, surface data is in MD file 6, mandatory level RAOB data is in MD file 16, significant level RAOB data is in MD file 26, and ship data is in MD file 36. For Julian Day 190, the current surface data is in MD file 10, etc.

Aside from those MD files set aside for current data, each user is assigned 16 MD files for his/her own use. In the following commands, substitute one of your assigned MD file numbers for the number 9999. To begin, MD file number 9999 should not yet contain a file.

```
13. MDU LIST 9999      MD#  CREATED  SCHM  PROJ  NR   NC    ID   DESCRIPTION
-----
--END OF LISTING
```

Lists Directory Information for MD File 9999. No information is given under the column headers, showing that the file is nonexistent.

Determine today's RAOB MD file number, using the last digit of the Julian day as described above, and substitute it for the 16 in the following command:

```
14. STABIL MAKE 16 9999 12          CALCULATING STABILITY PARAMETERS
Generates MD File 9999, then calculates STABILITY PARAMETERS ARE IN MD FILE = 9999
stability indices for Day 84186 at 12 GMT, CURRENT MD FILE IS 9999
and stores them in MD File 9999.
```

```
15. STABIL PLOT SAT 9999          --PLOTING DONE
Plots the stability indices contained in MD File 9999 on the graphics frame.
```

The following commands can be used to list data on your CRT or printer. (Continue substituting your assigned MD file number for 9999 as you did above.)

```
16. MDO 9999 KEYS=LIST          (See Fig. 3)
Lists the keywords associated with the stability records.
```

```
17. MDO 9999          (See Fig. 4)
Lists the first record of the MD File which contains data.
```

The keys in a stability index record are quite different from those in a SVC-A record. Substitute today's SVCA MD file number for the 6 in the following command:

```
18. MDO 6 KEYS=LIST          (See Fig. 5)
Lists the key words associated with the SVC-A records.
```

NAME	UNIT	NAME	UNIT	NAME	UNIT
----	----	----	----	----	----
DAY	SYD	TIME	HMS	IDN	
LAT	DEG	LON	DEG	ZS	M
ST	CHAR	TDP	K	THAP	K
THEP	K	MIXP		WV	MM
TCON	K	FMAX	K	LI	K
TOT	K	PEQU	MB	KINX	K
SWET					

MDO -- DONE

Fig. 3. Listing of keywords from a stability index record.

--RECORD AT (ROW,COL) = (3, 2)

[DAY =	84186	SYD	[TIME =	120000	HMS	[IDN =	70086
[LAT =	70.1300	DEG	[LON =	143.6299	DEG	[ZS =	15 M
[ST =	AK		[TDP =	267.34	K	[THAP =	292.52 K
[THEP =	300.12	K	[MIXP =	2.71		[WV =	7.93 MM
[TCON =	305.12	K	[FMAX =	293.60	K	[LI =	7.85 K
[TOT =	26.82	K	[PEQU =	667.9	MB	[KINX =	-4.19 K

MDO -- DONE

Fig. 4. Example of one record from a stability index file.

NAME	UNIT	NAME	UNIT	NAME	UNIT
----	----	----	----	----	----
DAY	SYD	TIME	HMS	NREC	
IDN		LAT	DEG	LON	DEG
ZS	M	ST	CHAR	MOD	
HMS	HMS	LEV	CHAR	P	MB
T	K	TD	K	DIR	DEG
SPD	MPS	Z	M		

MDO -- DONE

Fig. 5. Listing of keywords from a SVC-A record.

D1/19/08

COMMANDCRT RESPONSE

- | | | |
|-----|--|---|
| 19. | MDO 9999 ALL KEYS=IDN LI
Lists all station identifiers
along with their lifted index
values from MD File 9999.
(If you do not use 'ALL', only
the first identifier and lifted
index are listed.) | IDN LI
70086 7.85
70261 -4.04
70273 2.80
. ETC. .
. .
MDO -- DONE |
| 20. | SL MKC 12 18
Lists hourly surface station
data for Kansas City from
12 GMT to 18 GMT | (See Fig. 6) |
| 21. | YA SA PIA
Lists the current SA
observation for Peoria. | (See Fig. 7) |
| 22. | YA SD DAB
Lists the current radar
report for Daytona Beach
if one is available. | (See Fig. 8) |
| 23. | YA 282 ALL REPORTED
Lists severe weather reports
by searching for the string,
'reported'. | (See Fig. 9) |
| 24. | LOGOFF | |

In the commands used above, we took advantage of many available default parameters. You have many more options to choose from. See the chapters on Weather Analysis (Ch. 11) and Files (Ch. 8) in the McIDAS User's Manual to see the variety of options available for these commands.

08/D1/19

M	DDHHMM	ST	ID	T	TD	WIND	GG	PSL	LMH	VIS	WX	ZCL	ZCM	ZCH	PCP	SNO
	41347	MO	MKC	21	18	0305		1013.4	300	4.8	RW-F	12				
S	41416	MO	MKC			0805		1011.7	230	9.7	F	15	37			
	41448	MO	MKC	22	19	0604		1011.1	230	11.3		15	37			
	41545	MO	MKC	23	19	0806		1009.4	102	11.3		2	0	61		
	41645	MO	MKC	25	18	1505		1009.7	202	11.3		15	0	61		
	41745	MO	MKC	26	18	0702		1011.1	300	16.1		15				

SL COMPLETED...

Fig. 6. Listing of surface hourly data from Kansas City. Available data from 12 GMT to 18 GMT on 4 July 1984 is shown.

PIA SA 1648 E35 BKN 90 OVC 21/2RW-F 111/76/72/2605/987/RB25 PCPN
 VRY LGT
 YA -----DONE

Fig. 7. The 17 GMT SA for Peoria on 4 July 1984.

DAB 1725 AREA 1TRW++/+ 66/150 127/175 194/160 271/45 C2010 MT 370
 AT 176/111
 AREA 3TRW++/+ 294/145 271/110 22W C2610 MT 440 AT 280/113
 ^MM2001 NG2000222 OG24 ON300101 PR1 Q041 R02 S01=
 YA -----DONE

Fig. 8. Radar report from Daytona Beach taken at 1725 GMT on 4 July 1984.

WWUS1 KGWC 032005
 SEVERE WEATHER REPORTED NR 023
 WIND DAMAGE...WARWICK,NY...31SW POU...APRXLY 1930Z.

WWUS1 KGWC 031832
 SEVERE WEATHER REPORTED NR 023
 UNCONFIRMED TORNADO...MILTON, FL...13 NE PNS...1806Z.

WWUS1 KGWC 030615
 SEVERE WEATHER REPORTED NR 022
 UNCONFIRMED TORNADO...MERRITT RESERVOIR,NE...20 SW VTN...0330Z

YA ---DONE

Fig. 9. Listing of severe weather reports found by searching the file for the string 'reported'.

D1/19/08

PSEUDO COLORING

Pseudo coloring, also referred to as enhancement, is used to improve picture contrast or to produce colored imagery. The relationship between the pixel's digital value and its brightness, while ordinarily proportional, is redefined, but only for the TV presentation. The original digital data in the areas is not altered. Though this digital data has a brightness range of 0 to 255 (8 bit data), most pseudo coloring commands refer to the brightness range of 0 to 63 because it is inherent in the TV display system (6 bit data). Most enhancements require a subset range of such brightness values as inputs over which the pseudo coloring is to be performed.

A particular enhancement can be conceptualized as three tables (blue, green, and red), with rows numbered from 0 to 63 and with 1 column. The values in the column are defined by the various pseudo coloring commands. So for each pixel contained in the TV refresh memory, its brightness corresponds to one of the rows in each table. The value read out of the column along that row is displayed as a gray scale or colored pixel on the TV monitor. (See Fig. 10.)

Several types of enhancements are available. The simplest enhancement improves the contrast of the gray scale picture, namely black and white contrast stretching. In this case, input and output brightness ranges may be specified as command inputs or, alternatively, the joysticks may be used as input values, moving them in the X or Y direction until a desirable

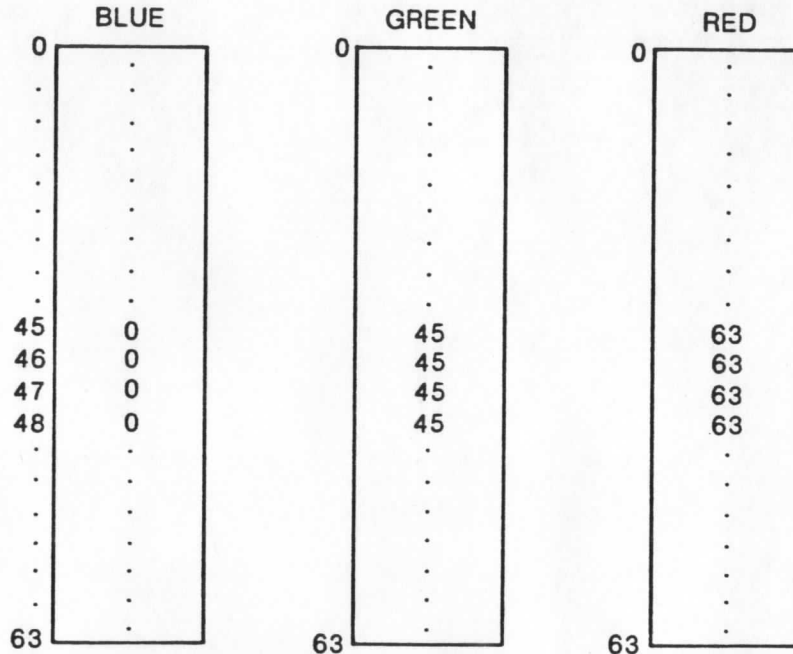

Figure 10: AN EXAMPLE OF AN ENHANCEMENT TABLE WHERE INPUT IMAGE BRIGHTNESSES FROM 45 TO 48 ARE OUTPUT AS THE COLOR, GOLD.

contrast is attained. A basic color enhancement table is obtained by specifying various brightness ranges which are to be colored with chosen shades of any of 20 available colors or blends of those colors. These colors are loaded into the columns of the enhancement tables as output values for the specified brightness inputs (Fig. 10.).

A gray scale stretching technique is available to use with the image loading command (DF) to bring out more detail in certain brightness ranges of the image. For example, a 15 degree temperature range from 210 to 225 K may only cover 4 brightness counts in the 0 to 63 range. After applying the stretching command, the same temperature range may cover 15 brightness counts. As a tradeoff, the temperatures above 225 K are now less well defined, being linearly interpolated between counts 40 and 0. This allows the user to augment certain areas of an image such as thunderstorm cloud tops, showing 1 or 2°C temperature changes, while decreasing the contrast of low clouds or ground temperatures (See Fig. 11.).

Other types of color enhancements are available for frame overlays using the *N* key (i.e., pictel interlace switch). The *N* key switches the pseudo coloring table in and out of the data path leading to the TV monitor. A 63 by 63 pseudo coloring table may be constructed by applying

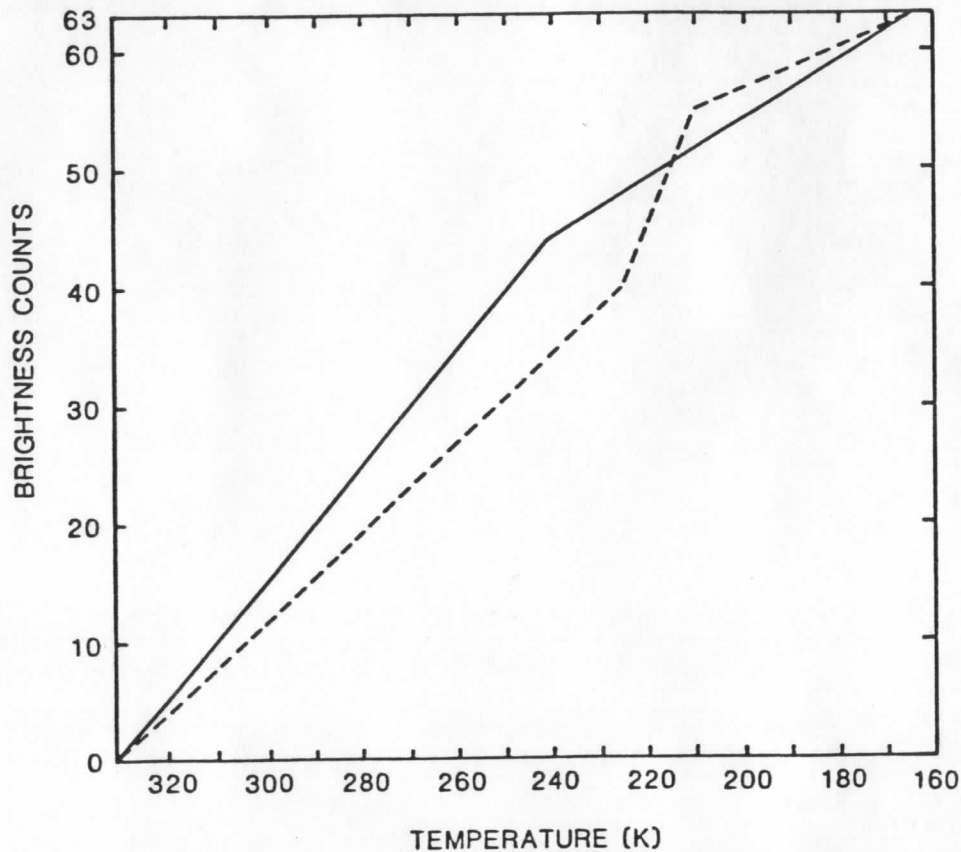

Figure 11. RELATIONSHIP OF TEMPERATURE (K) TO BRIGHTNESS FOR:
 ——— STANDARD ENHANCEMENT TABLES
 - - - - IR GRAY SCALE STRETCHING TABLE EXAMPLE.
 TEMPERATURES FROM 210 TO 225 ARE
 STRETCHED OVER BRIGHTNESS COUNTS 40 TO 55.

functions such as logical or, logical and, arithmetic difference, or geometric mean to two enhancement tables. The two frames are combined pixel by pixel, and the combination is displayed on the TV monitor. Similarly, false stereo images are created by combining a green enhancement table with a red enhancement table.

The *N* key is also used with a single enhancement table which is typically the color enhancement applied to the infrared image. For example, the current enhancement on the IR image can be used to color the visible image on the opposite frame, or the visible image may be colored with IR information, in only those areas which fall within both IR and visible input thresholds.

The current enhancement table on your terminal can be saved and then restored during a future terminal session. Each terminal has 260 tables available. However, another user could write over any saved table. You could enter the commands for creating particular enhancements into a string table as an alternate means of saving the enhancement.

A practice session dealing with enhancements begins on page 29.

PSEUDO COLORING PRACTICE SESSION

The following practice session will familiarize you with both black and white and color enhancements. These examples will not necessarily produce the best enhancements for any given image. Since image brightnesses vary with the current weather situation, the appearance of the enhancements will vary depending on the imagery used. Please read the section on pseudo coloring before starting this session.

<u>COMMAND</u>	<u>CRT RESPONSE</u>
Load a visible GOES image, with a resolution of 4 km, onto a current lower number frame and load the corresponding IR image onto the opposite higher number frame. (i.e. DF <area> <frame> EC 38 90)	
1. Start on the visible image with both joysticks down to the left.	
EB Starts up the black and white contrast stretching program in the joystick mode. Move one of the joysticks and strike the R key.	TYPE <R> TO START AND <.> TO END
Move either joystick to several different positions, striking the R key as you move to see the variations available. Strike a . key. Ends the joystick mode.	TYPE <R> TO START AND <.> TO END BLACK AND WHITE ENHANCEMENT COMPLETED
2. EL Restores the original gray scale.	EL FINISHED
3. EB 10 40 5 60 Input brightness values of 10 are output at 5 and values of 40 are output at 60. EL Restores the original gray scale.	BLACK AND WHITE ENHANCEMENT COMPLETED EL FINISHED
4. DC 15 Changes cursor size to 15 pixels in height and width.	None
5. Move the cursor over the brightest area of clouds. OD E Lists the brightness counts for each pixel within the cursor on the 0 to 63 scale (i.e., 0 to 255 divided by 4).	(See Fig. 12)
6. CS LIST PALLET Lists the colors available and their blue, green, and red counterparts.	(See Fig. 13)

Fig. 12. Listing of colors available in the system library.

LIBRARY COLOR PALLET

COLOR	BLUE	GREEN	RED
BLACK	0	0	0
RED	0	0	31
GREEN	0	31	0
BLUE	31	0	0
YELLOW	0	31	31
MAGENTA	31	0	31
CYAN	31	31	0
WHITE	31	31	31
BROWN	4	4	16
VIOLET	25	15	31
GOLD	0	23	31
PURPLE	15	0	15
ORANGE	0	15	31
NAVY	14	0	0
SKY	31	20	0
BEIGE	15	21	31
LEMON	8	31	28
AVOCADO	4	16	8
PINK	15	15	31
GRAY	15	15	15

COLOR LIBRARY LIST DONE

Fig. 13. Output of enhancement compatible brightness counts within the cursor.

DIGITAL DATA FOR SATELLITE=29 ON 84171 AT 133100

PART 1

46	46	47	47	47	47	47	47	47	47	47	47	46	46	46	46
47	47	47	47	47	47	47	47	47	47	47	47	47	47	47	47
47	47	47	47	47	47	47	47	47	47	47	47	47	47	47	47
48	48	48	48	48	48	48	48	48	48	48	48	48	48	48	48
48	48	48	48	48	48	48	48	48	48	48	48	48	48	48	48
48	48	48	48	48	48	49	49	49	49	49	49	49	49	49	49
48	48	48	48	48	48	49	49	49	49	49	49	49	49	49	49
48	48	48	48	49	49	49	49	49	49	49	49	49	49	49	49
48	48	48	48	49	49	49	49	49	49	49	49	49	49	49	49
48	48	48	48	48	49	49	49	49	49	49	48	48	48	48	48
48	48	48	48	48	49	49	49	49	49	49	48	48	48	48	48
48	48	48	48	48	48	48	48	48	48	48	48	47	48	47	47
48	48	48	48	48	48	48	48	48	48	48	48	47	48	47	47
47	47	47	47	47	47	47	47	47	47	47	47	47	47	47	47
47	47	47	47	47	47	47	47	47	47	47	47	47	47	47	47

08/D1/15-8

7. Since the brightest pixel count in this example is 49:
 EL 49 63 63 63 63 63 63 63 63 EL FINISHED
 Colors brightness counts 49
 to 63, white.

NOTE: The values for blue, green, and red color guns listed in the pallet must be doubled for use in the EL command

EL 46 47 0 0 63 63 0 0 EL FINISHED
 Colors brightness counts 46
 to 47, bright green.

EL 44 45 0 0 63 63 63 63 EL FINISHED
 Colors counts 44 to 45, yellow.

EL 40 43 0 0 0 0 63 63 EL FINISHED
 Colors counts 40 to 43, bright red.

EL 35 39 63 63 20 20 0 0 EL FINISHED
 Colors counts 35 to 39, bright blue.

The colors obtained above are all solid colors because no color ranges were designated. Each pair of numbers given for each color gun were the same. Try EL 35 39 0 63 0 0 0 0. This colors counts 35 to 39 in all shades of blue instead of one shade. Next try EL 35 39 20 63 0 0 0 0. Counts between 35 and 39 are shades of blue, linearly stretched over counts 20 to 63.

8. ES 18 "TEST ENHANCEMENT SAVE DONE TEST
 Saves the current enhancement
 table in table number 18 along with
 a comment.
9. EL EL FINISHED
 Restores original gray scale.
10. ER 18 ENHANCEMENT RESTORE DONE 18 TEST
 Restores the enhancement
 saved in Table 18.

The following commands are for frame overlays (N key).

11. ET CUR 5 , then strike the ET COMPLETED...
 N key.
 Colors the visible and IR overlay
 with the current enhancement on the IR.
12. ET TIN 2 25 30 35 40 45 ET COMPLETED...
 Lightly colors the visible
 image with brightness information
 from the infrared image.

COMMANDCRT RESPONSE

13. ET CON 30 50 35 45 2 35 37 39 42 45 ET COMPLETED...
 Lightly colors the visible
 image data that falls within both
 the given visible and infrared
 thresholds.

The following example shows the use of an IR gray-scale stretching table.

Load a new IR image
 DF <area> <frame> EC 38 90 BEGIN TV LOAD 12
 FRAME ADDED TO OUTPUT QUE 12

14. IS CLE 5 IS CLE IS FINISHED
 Clears table 5.

15. IS DEF 5 217 50 220 47 223 44 226 41 230 37 235 32 UNIT = K DEF FINISHED
 Defines Table 5. Input temperatures (K)
 are output at given brightnesses.

16. IS LIS 5 UNIT = K INPUT 330 OUTPUT 0
 Lists table 5 in terms of INPUT 235 OUTPUT 32
 input temperatures and INPUT 230 OUTPUT 37
 output brightnesses. INPUT 226 OUTPUT 41
 INPUT 223 OUTPUT 44
 INPUT 220 OUTPUT 47
 INPUT 217 OUTPUT 50
 INPUT 163 OUTPUT 63
 LIS FINISHED

17. Reload the same IR image on the next consecutive frame, appending the table
 number to the location reference (i.e., EC5).

DF <area> <frame> EC5 38 90 IR TAB MOD USED IN TV LOAD
 BEGIN TV LOAD 13
 FRAME ADDED TO OUTPUT QUE 13

Flip back and forth between the two IR images (using A and B keys). Notice the
 change in the gray scale shading.

Next, color each of the temperature ranges defined in the above table:

18. EL 50 63 63 63 63 63 63 63 EL FINISHED
 Counts 50 to 63 are colored white.
 Thus, any temperatures at or
 Below 217 K are shown in white.
 EL 47 49 0 0 63 63 0 0 EL FINISHED
 Counts 47 to 49 (temperatures 218
 to 220 K) are colored green.
 EL 44 46 0 0 63 63 63 63 EL FINISHED
 Counts 44 to 46 (temperatures 221
 to 223 K) are colored yellow.
 EL 41 43 0 0 0 0 63 63 EL FINISHED
 Counts 41 to 43 (temperatures 224
 to 226 K) are colored red.

COMMAND

CRT RESPONSE

EL 37 40 63 63 0 0 63 63
Counts 37 to 40 (temperatures 227
to 230 K) are colored magenta.
EL 32 36 63 63 20 20 0 0
Counts 32 to 36 (temperatures 231
to 235 K) are colored light blue.

EL FINISHED

EL FINISHED

Flip back and forth between the two IR images again (using *A* and *B* keys). Notice the greater amount of cloud top detail in the stretched gray scale image than in the original image.

19. SG 1
Shows graphics frame 1.

None

20. EG

ERASED GRAPHICS FRAME 1

21. IS GRA 5 UNIT = K
Draws a graph of brightnesses
verses temperature. (Striking
the *K* key makes it easier to view
the graph)

GRA FINISHED

22. EL
Restores original gray scale.

EL FINISHED

23. LOGOFF

The IR stretch table 5 will be present on the terminal until someone overwrites or clears table 5. As mentioned earlier, the commands for defining the IR stretch table and any accompanying color enhancements (EL) could be saved using string tables. See the chapter on Pseudo Coloring (Ch. 6) in the McIDAS User's Manual for additional information.

08/D1/15

STRING TABLES

Each terminal has a table of named character strings, called a string table or context table, residing on disc. The original use of strings was to provide a shorthand for typing in commands. For example, the string 35:30:15 98:25:40 can be assigned to the string name, LALO. Then, whenever #LALO appears in a command, it is replaced by 35:30:15 98:25:40. An entire list of such strings may be defined and then saved as a single named string table. During a future terminal session you can restore any string table previously saved. Some programs (i.e., SP, UC) access the current string table to obtain keyword values previously defined by you.

Once you become familiar with the basic string manipulations, string tables can become a powerful tool. Strings can be nested, allowing one string to access several others, or even access other string tables. Thus, string tables can be used for lengthy tasks such as loading several sets of images along with appropriate map outlines or defining an entire color enhancement table. Currently, the system allows a maximum of 136 saved tables, with a maximum of 256 strings per table.

When nesting strings, any #name is replaced by its value before the string is placed into the string table. i.e., *TE LOAD "DF 101 5 EC #LALO* would be filed as *LOAD :=DF 101 5 EC 35:30:15 98:25:40*. LALO must be defined before LOAD can be defined. If the LALO values are going to be changed and the LOAD string is always to use the current value of LALO, then use two pound signs, *TE LOAD "DF 101 5 EC ##LALO*, so that LOAD would be filed as *LOAD :=DF 101 5 EC #LALO*, and specific numbers would not be assigned to #LALO until the string LOAD is used.

Other important items to note:

- String names and string table names can be 1-12 letters long.
- Only the first position of a string name may contain a numeral.
- A string definition may be up to 160 characters long.
- Strings H and Y always contain the current time and date, and cannot be redefined.
- Whenever a new table is restored, the current table on the terminal is overwritten and any unsaved strings are deleted.
- String names with a ? as the first character are considered global, meaning they will not be deleted when another table is restored.

A practice session dealing with string tables begins on page 35.

STRING TABLE PRACTICE SESSION

The following practice session will show you how to create and save a string table. Please read the section on string tables before starting this session.

<u>COMMAND</u>	<u>CRT RESPONSE</u>
1. After logging onto the terminal, its current string table is automatically cleared. If you have not recently logged on, then do: TD ALL Clears the system table except for global strings.	TD STRING TABLE CLEARED.
2. TL Lists the first 20 lines of the current string table. H and Y always contain the current time and date.	H := 0:43:39 Y := 84146
3. TE EAST "EC 0 75 -6 Defines the string called East.	EAST :=EC 0 75 -6
4. TE WEST "EC 0 135 -6 Defines the string called West.	WEST :=EC 0 135 -6
5. TE LOADE "DF 105 4 #EAST Defines LOADE using the load coordinates defined in string East.	LOADE :=DF 105 4 EC 0 75 -6
6. TE LOADW "DF 115 5 #WEST Defines LOADW using the load coordinates defined in string West.	LOADW :=DF 115 5 EC 0 135 -6
7. TE WRITETIME "ZA 3 10 "#H	WRITETIME :=ZA 3 10 " 0:46:39
8. TE TIMENOW "ZA 3 10 "##H	TIMENOW :=ZA 3 10 "#H

Note: The time appearing in your command will be the current time as you key in the command, not 0:46:39.

Steps 6 and 7 demonstrate the difference in the #H vs. ##H. Move the cursor to the center of the screen and type a linefeed, #WRITETIME, Carriage Return. The same time, 0:46:39, will always be written with each execution of string WRITETIME. Next, move the cursor to another position, type #TIMENOW. TIMENOW always picks up the current time, so the result will be different with each execution of TIMENOW.

9. TL Lists strings defined above in alphabetical order.	EAST := EC 0 75 -6 H := 1:37:38 LOADE := DF 105 4 EC 0 75 -6 LOADW := DF 115 5 EC 0 135 -6 TIMENOW := ZA 3 10 "#H WEST := EC 0 135 -6 WRITETIME := ZA 3 10 " 0:46:39 Y := 84146
---	--

COMMANDCRT RESPONSE

- | | | |
|-----|---|--|
| 10. | TL L
Lists only those strings
beginning with the letter L. | LOADE :=DF 105 4 EC 0 75 -6
LOADW :=DF 115 5 EC 0 135 -6 |
| 11. | TD WEST
Deletes the string named West. | TD STRING DELETED |
| 12. | TD LOADW
Deletes the string named LOADW. | TD STRING DELETED |
| 13. | TL | Same as list in #9 without
WEST or LOADW. |
| 14. | TU SAVE PRACTICE
Saves the strings
defined above in a
table called PRACTICE.
Also lists out all string tables saved under the currently logged on
initials, the project they were saved under, the terminal they were
saved on, the date saved, and the date last restored. <i>TU LIST</i> gives
exactly the same listing. | <u>NUM</u> <u>SAVE</u> <u>NAME</u> <u>INIT</u> <u>PROJ</u> <u>TERM</u> <u>SAVED</u> <u>RESTORE</u>
119 PRACTICE DAR 6999 44 84146 84146 |
| 15. | TE SETUPE "SF 4 ; #LOADE ; SG 2 ; EG
SETUPE :=SF 4 ; DF 105 4 EC 0 75 -6; SG 1; EG
Defines string SETUPE to
do a sequence of commands. | |
| 16. | TU SAVE PRACTICE
Anytime new strings are added,
the table must be saved again. | Same listing as in #14. |
| 17. | #SETUPE
Shows image frame 4, loads
the East global picture, shows
graphics frame 1 and erases it. | BEGIN TV LOAD 4
FRAME ADDED TO OUTPUT QUE 4
ERASED GRAPHICS FRAME 1 |

The string table called PRACTICE has been saved and will remain in the system string table file even after you log off. If you want to access this table during your next terminal session, do *TU REST PRACTICE* to restore the PRACTICE table to the current table at this terminal. If you are logged on under initials other than those which were used to save the PRACTICE table, do *TU REST PRACTICE <original initials>*. If you wish to delete this table now, do *TU DEL PRACTICE*. As a result, PRACTICE will no longer appear when you do a *TU LIST* since it has been deleted from the system Save File. However, the strings still appear when you do a *TL* because PRACTICE is still the current string table on the terminal.

See Chapter 13 of the McIDAS User's Manual for additional information on string tables.

08/D1/12

DATA TABLET/GRAPHICS OVERLAY

The data tablet or graphics overlay simplifies the entering of McIDAS commands. Instead of typing in commands via a keyboard, the user may select certain commands, previously defined in a string table, using a pen on a data tablet or using a cursor on a graphics overlay. The data tablet is a physical device connected to the terminal with a predefined static set of commands assigned to certain areas or boxes on the tablet. When the pen touches a box, the corresponding command is executed. On the other hand, the graphics overlay is an easily changeable graphic on the video screen, and like the physical tablet, commands are assigned to certain boxes. The joysticks are used to position the cursor over the desired box. Striking the S key causes the corresponding command to be executed.

An overlay or tablet consists of boxes created by the user with the cursor or pen. When first creating the data tablet using the pen on the tablet, the resulting boxes will be drawn on the video screen, not the tablet, to enable you to observe your results. When creating the overlay using the cursor, the boxes are, by definition, drawn on the graphics of the video screen.

The tablet and overlay make use of strings and string tables to define the function of each box. You create the strings and choose which box to assign them to. Boxes may be declared as map regions or be defined as certain commands. The pen or cursor may initiate a string which simply contains one command or the string itself may initiate several other strings to execute an entire sequence of commands. Each string can have up to 160 characters.

Two points define a box. Each box has a name consisting of 1-2 letters starting at A and ending at ZZ, assigned in the order in which the boxes are defined. The box name is used when assigning command strings or when dividing boxes. In addition, each box may be labelled with a descriptor related to the function of the particular box.

A large box may be divided into a number of smaller boxes. These subset boxes are considered to be unique, and only the string associated with the smallest subset selected will be executed. If boxes overlap, then the intersection is considered to be common to all and strings associated to each are executed in the order that the boxes were defined. A maximum of 250 boxes are allowed per overlay and a maximum of 256 possible overlays may be saved on the system.

A practice session for creating a graphics overlay begins on page 38.

GRAPHICS OVERLAY PRACTICE SESSION

The following practice session will show you how to create and store a graphics overlay. Please read the section on Data Tablet/Graphics Overlay before starting this session.

COMMAND

CRT RESPONSE

Start out on an empty graphics frame. Do an EG if necessary to erase the graphics. Also hit a *K* key to turn off the image frame. The graphics overlay is the default mode. It is possible to scale the overlay to the data tablet.

- | | |
|---|---|
| 1. TD ALL
Clears the system string table. | TD STRING TABLE CLEARED |
| 2. DTB MAKE TEST
Initiates the program to build a graphics overlay with the name TEST under the signed on initials, NNN. | PREPARED TO DEFINE---TEST /NNN
ON THE WRRM |
| 3. Move the cursor to the upper lefthand corner of the screen and hit the <i>S</i> key to enter points into the box definition table. A small x is drawn on the screen. | TABWRM---COMPLETED |
| Move the cursor about 3 inches to the right and to the bottom of the screen. Hit the <i>S</i> key again. Another x and then box A is drawn. | BOX=A
TABWRM---COMPLETED |
| Without moving the cursor, hit <i>S</i> . | TABWRM---COMPLETED |
| Move the cursor to the upper right-hand corner of the screen, hit <i>S</i> . Box B is drawn. | BOX=B
TABWRM---COMPLETED |
| 4. DTB END "PRACTICE OVERLAY
Ends the make mode and adds an optional memo to describe the overlay. | DTB END---COMPLETED |
| 5. DTB DIV A 20 2
Divides Box A into 20 rows by 2 columns. | SUB-DIVIDING DTA INTO A 20 BY 2
DTB DIVIDE DTAO ---COMPLETED |
| 6. DTB LIST
Lists the box coordinates in TV lines and elements. | (See Fig. 14) |

If desired, any box coordinates could be changed using *DTB CHA* or more boxes may be added using *DTB MAKE* and *DTB END* as above.

NAME=TEST /NNN	SCALED	TO WRRM	MEMO:PRACTICE OVE			COLOR	SIZE
BOX	ULIN	UELE	LLIN	LELE	LABEL		
---	----	----	----	----	-----	-----	----
BORDER	15	1	482	609			
A	15	1	38	106			
B	25	211	482	609			
C	15	106	38	211			
D	38	1	61	106			
E	38	106	61	211			
F	61	1	84	106			
G	61	106	84	211			
H	84	1	107	106			
I	84	106	107	211			
J	107	1	130	106			
K	107	106	130	211			
L	130	1	153	106			
M	130	106	153	211			
N	153	1	176	106			
O	153	106	176	211			
P	176	1	199	106			
Q	176	106	199	211			
R	199	1	222	106			
S	199	106	222	211			
T	222	1	245	106			
U	222	106	245	211			
V	245	1	268	106			
W	245	106	268	211			
X	268	1	291	106			
Y	268	106	291	211			
Z	291	1	314	106			
AA	291	106	314	211			
AB	314	1	337	106			
AC	314	106	337	211			
AD	337	1	360	106			
AE	337	106	360	211			
AF	360	1	383	106			
AG	360	106	383	211			
AH	383	1	406	106			
AI	383	106	406	211			
AJ	406	1	429	106			
AK	406	106	429	211			
AL	429	1	452	106			
AM	429	106	452	211			
AN	452	1	482	106			
AO	452	106	482	211			

DTB LIST --- COMPLETED

Fig. 14. Listing of all box coordinates for the Practice Overlay

COMMAND

CRT RESPONSE

- 7. DTB DEL A0
Deletes Box A0 from the box definition table. DTE DELETE---COMPLETED

- 8. DTU SAVE # NUM SAVE NAME INIT PROJ TERM SAVED RESTORE
Saves the overlay and its corresponding string table in the system Save File. The Overlay File holds boxes, labels, and maps. The String Table File holds commands. The overlay is saved under the name given above in DTB MAKE and also under the initials with which you are currently signed on. -----

1	4	TEST	NNN	9999	67	84160	84160
---	---	------	-----	------	----	-------	-------

TU COMPLETED
DTU SAVE ---COMPLETED

- 9. DTU LIST NUM SAVE NAME INIT PROJ TERM SAVED RESTORE
Lists overlays saved under the current initials. DTU LIST ALL lists entire Save File contents. -----

13	TEST	NNN	9999	67	84160	84160
----	------	-----	------	----	-------	-------

DTU LIST---COMPLETE

- 10. DTE A "LA 101 104
Enters the command for Box A into the string table. DTA := LA 101 104

- 11. DTE LAB A 6 3 "VIS RES 1
Labels Box A with letters 6 pixels high in color level 3. DTE --- COMPLETED

The label is centered within the box. TV cordimates may be used to place the label anywhere within the box.

- 12. DTE C "LA 105 108; TABCOL 3 F G H I
Enters two commands for Box C into the string table. DTC := LA 105 108 ; TABCOL 3 F G H I
TABCOL is a data tablet command for changing the color of specified boxes. In this case, boxes F G H and I are changed to color level 3.

- 13. DTE LAB C 6 3 "VIS RES 4
Labels Box C. DTE COMPLETED

- 14. DTE D "SL WI
Enters the command for Box D into the string table. DTD := SL WI

- 15. DTE LAB D 6 3 "SL WI
Labels Box D. DTE --- COMPLETED

- 16. DTE MAP B WI
Draws map of Wisconsin in Box B. IC SEARCH OF MAP FILE OUTLUSA
IC DONE
DTE --- COMPLETED

<u>COMMAND</u>	<u>CRT RESPONSE</u>
17. DTE E "TABERA B Defines Box E to erase Box B.	DTE := TABERA B
18. DTE LAB E 6 3 "ERASE B Label Box E.	DTE --- COMPLETED
19. DTE ERA E Erases the contents of a box so you can change its label.	DTE ERA---COMPLETED
20. DTE LAB E 6 3 "ERASE MAP Relabels Box E.	DTE --- COMPLETED
21. DTE LIST E Lists strings associated with Box E.	DTE := TABERA B --END OF LIST
22. DTE F "DF 105 1 EC 38 90 ; TABCOL -3 F G H I Using -3 in the TABCOL command will change the box back to its original color.	DTF := DF 105 1 EC 38 90 ; TABCOL -3 F G H I
23. DTE LAB F 6 3 "105 38N 90W	DTE --- COMPLETED
24. DTE G "DF 106 1 EC 38 90 ; TABCOL -3 F G H I	DTG := DF 106 1 EC 38 90 ; TABCOL -3 F G H I
25. DTE LAB G 6 3 "106 38N 90W	DTE --- COMPLETED
26. DTE H "DF 107 1 EC 38 90 ; TABCOL -3 F G H I	DTH := DF 107 1 EC 38 90 ; TABCOL -3 F G H I
27. DTE LAB H 6 3 "107 38N 90W	DTE --- COMPLETED
28. DTE I "DF 108 1 EC 38 90 ; TABCOL -3 F G H I	DTI := DF 108 1 EC 38 90 ; TABCOL -3 F G H I
29. DTE LAB I 6 3 "108 38N 90W	DTE --- COMPLETED
30. TE GLL "GLINE=26 481 GELE=212 608 Sets up the line and element outline of the map.	GLL := GLINE=26 481 GELE=212 608
31. DTE J "TABUP;MDX CLE;MDX CLE;MDX T MAP=WI DEV=GRA #GLL MD=#MYSVCA UNIT=F Sets the SVCA and RAOB MD Files to the current day and time. Clears the MDX table. Then plots the temperature (°F) in Box B on the WI map.	DTJ := TABUP;MDX CLE;MDX T MAP=WI DEV=GRA GLINE=26 481 GELE=212 608 MD=(NNNN) UNIT=F

COMMANDCRT RESPONSE

32. DTE LAB J 6 3 "PLOT SFC T
Labels Box J. DTE --- COMPLETED
33. DTU SAVE
Saves the strings and labels
defined above. Same list as in #8
- To try out some of the functions on the overlay, move the cursor to
Box D and hit the *S* key. A surface listing for Wisconsin will be
produced on the CRT. TABWRM---COMPLETED
- Move the cursor to Box A and hit *S*. Areas 101 to 104 will be listed
on the CRT. TABWRM---COMPLETED
- Move the cursor to Box C and hit *S*. Areas 105 to 108 are listed, and
the color of boxes F G H and I is changed to color level 3.
TABWRM---COMPLETED
- Hit the *K* key to turn the image back on. Go to Frame 1 (SF 1).
Move the cursor to Box G and hit *S*. Area 106 will be loaded in Image
Frame 1, centered on 38N and 90W. TABWRM---COMPLETED
- Hit *K* to turn the image off again.
Move the cursor to Box E and hit *S*. The map in Box B is erased.
TABWRM---COMPLETED
- Move the cursor to Box J and hit *S*. Current surface temperatures (°F)
are plotted on the Wisconsin map. MDX CLEAR DONE.
COMPLETED
---COMPLETED
TABWRM---COMPLETED
34. EG ERASED GRAPHICS FRAME 1
Erases the overlay.
35. DTB SHOW IC SEARCH OF MAPFILE OUTLUSA
Redraws the overlay on the IC DONE
graphics. Puts large box DTB SHOW --- COMPLETED
around entire screen.
36. EG ERASED GRAPHICS FRAME 1
Erases overlay again.
37. DTB DRAW IC SEARCH OF MAPFILE OUTLUSA
Redraws overlay on the IC DONE
graphics without box names. DTB DRAW --- COMPLETED

If you want to display your saved overlay during a future terminal session, you must do *DTU REST <save name>* to restore your overlay and corresponding string table to your terminal. If you previously saved the overlay under initials other than those with which you are currently signed on the terminal, do *DTU REST <save name> <save initials>*.

McIDAS OPERATIONS PROCEDURES AND POLICIES

1. Operators are on duty Monday through Friday, 7:30 AM to 11:00 PM (central time) excluding holidays.

2. System maintenance is performed daily at the following times:

Between approx 10:15 to 11:00 PM, McIDAS is taken down to pack the system libraries. (Down time varies from 5 mins to 45 mins.)

* When McIDAS is restarted, you must sign back on before any scheduled TVLOADS will work. If this presents a problem, contact the operators. We can make the system sign your terminal on when McIDAS comes up.

3. Source software is backed up daily onto mag tape, but there is no backup of user data. Be sure to contact the operator to "save" your data onto tape.

* It is highly recommended that you have your data put onto tape, as any malfunction in hardware, software or user error can (and has) wiped out data.

4. Any important information that system users should be aware of is put into the logon message. It will appear whenever the terminal is logged onto. The type of message that may appear may be about software changes, scheduled down time, change in the operator's schedule due to illness, holidays, vacation, etc. If the terminal is already logged on, then type *SEE LOGON* to get the logon message. The file *DNNEW* contains new programs added to the system within the last month. Type *SHOWME DNNEW* to look at the file. To see more than one page, key-in *SHOWME* again.

5. Disk storage for data is assigned to users in blocks of 16. The same group of file numbers apply for areas/soundings, MD files and grid files, (i.e., 16 areas, 16 MD files, 16 grid files). To get a block of files assigned to you, contact the operators. If you wish, these files can be assigned to a specific project number to avoid accidental deletion by other users.

6. Conventional weather data (surface and upper air) is available from March 1976 to present for SVCA and from April 1977 to present for RAOB. Data before 1978 and from Jan. 1, 1984 to Feb. 1984 is spotty.

7. Current SVCA, RAOB, and ship data is on disk for the current day and the previous 3 days. The way to access this data is by getting the Julian day for the day--(i.e. Feb. 13, 1984 = day 44); the last digit of the Julian day is the key:

Current data for day 44 is:

SVCA is in	MD files 1-10	MD file 4
Mandatory RAOB	MD files 11-20	MD file 14
Significant RAOB	MD files 21-30	MD file 24
Ship reports	MD files 31-40	MD file 34
FOUS data	MD files 41-50	MD file 44

Other FAA 604 data, such as NMC forecast products, weather advisories, terminal forecasts, etc., are accessible through the YA command.

8. Satellite data is stored on disk from GOES East, West and VAS. This data can be found in the following areas:

EAST

½ mi USA visible - areas 101-104 (up to 2 hrs depending on schedule)
2 mi Globe visible - areas 105-108
2 mi Globe IR - areas 109-112

WEST

2 mi vis Globe - areas 115-116 (up to 1 hour of data available depending on schedule)
2 mi IR Globe - areas 117-118
½ mi vis - areas 119-120

VAS-EAST

MSI sounding data 1101-1110 generally 5 hours of data *
DS sounding data 1301-1310

VAS-WEST

MSI sounding data 1121-1130 generally 5 hours of data *
DS sounding data 1321-1330

- * VAS is either East or West, never both, and the schedule changes often so area file numbers may vary slightly. For up-to-date info contact the operator.

9. To have data restored from tape you must contact the operators. Please allow 2-3 hours for tape loading.
10. All data files (areas, MD files and grid files) are purged from the system the 1st of every month. A warning message appears in the logon message 1 week in advance.
11. If you have any problems, either hardware or software, please contact the operators. They will either handle the problem or put you in touch with the correct person.
12. To contact the operators, phone (608) 262-0502 or send a terminal message via *WTOR*.

08/D1/20

GLOSSARY OF MCIDAS TERMS

<u>TERMS</u>	<u>DEFINITION</u>
Abort	Cancel a command that has begun executing. To abort a command first determine its initiator number; use the SS command for a listing of executing programs and their corresponding initiators, listed as INI01, INI02, etc. Now abort it by typing a slash followed by the initiator number (/ initiator). When the command has aborted, a message is sent to your CRT; \$INIT00 : RESTARTED To abort initiator 1 (INI01) use: / 1
Area	A temporary digital disc file used to store image sectors in a form that is easily accessible to the computer for computations. The user has complete flexibility when creating a disk area to choose the destination, positioning, and spatial resolution. Areas are sequentially numbered from 1 to 6999. Ask the computer operator for your area numbers.
Area Coordinates	The coordinates of a pixel in a digital disk area. These coordinates are located by referring to sequentially numbered rows and columns. Row 1 and column 1 are located in the upper left hand corner of the area.
Area Size	A count of the number of lines and elements making up an area. A TV screen is filled by a 480 X 640 area.
Blowup - Blowdown	Refers to changing the image resolution by sampling or averaging data in a blow-down, or repeating data in a blow-up.
Column	The horizontal coordinates referred to in MD files.
Command	A McIDAS function started by a user or a terminal. This can be done by typing a "line feed", a 2 to 6 character command name, followed by input numbers or text, and a carriage return. Or input by a single key stroke without a "line feed" or "return".
Communications Timeout	When this message appears on the CRT it means that your terminal is not functioning correctly. Notify the computer operators of your terminals condition. After the message disappears you can log back on to the system and continue working.
Color Pallet	A predefined list of 20 colors and their red, green and blue color components.
Conformal	A map projection in which small regions are represented with true shapes and angles are preserved.

CRT	Stands for Cathode Ray Tube. All multi-letter commands and their responses will appear on your CRT.
Cursor	A visible mark which appears on the TV monitor over the displayed frame. This is a special purpose output device used to point to portions of a displayed image. Eight cursor color levels and five shapes are available on each terminal. The cursor can be moved with the joysticks or command PC.
Data Tablet	Programmable data tablets are used to simplify the entering of commands. Once programmed, a specific location selected by a pointer can perform a specific function.
Digital Data	Data stored in the computer's memory or disks. Often specifically refers to the gray scale (8-bit brightness values) in areas. Its brightness values range from 0 (black) to 255 (white).
Earth Coordinates	An image sector extracted from a satellite image has pixels locatable in earth coordinates (latitude, longitude). The image must be navigated in order to access earth coordinates. West and North are positive, East and South are negative.
Element	Each division of the image along a scan line consisting of a sequence of image elements (or pixels). They are numbered left to right, the leftmost element being numbered one.
Frames	Image and graphic frames are arranged in a sequence. Image frames display digital data and graphic frames display WRRRMs. Only one frame of each type can be displayed at any time and the graphic frame can be overlaid on the image frame.
Graphics	Refers to miscellaneous general purpose commands used to manipulate graphic images on the WRRRM graphics hardware. Eight graphic levels are available on each terminal. Each graphic level can correspond to a different color from the color pallet allowing for eight different color levels to be simultaneously displayed on each graphics frame. Each color can be assigned with command CS.
Gray Scale	The gray scale ranges from 0 (black) to 63 (full white or full color). This range is used only by the TV display system. With linear enhancement, the gray scale value (range 0 to 63) is one-fourth of the digital data value (range 0 to 255) in the area. The gray scale values can be assigned pseudo colors using command EL.

Grid Files Grid files contain gridded fields analyzed at regularly spaced latitude and longitude locations from observational data. There are 6999 grid files available on McIDAS. Each grid file can hold a maximum of 159 grids. Each user is assigned grid file numbers which correspond to their area numbers.

Image An image is a two dimensional array of digitized data from a satellite. TV screen images are typically made up of 500 rasters (rows) by 640 pictels (columns).

Image Coordinates Refers to a satellite based coordinate system. Each image consists of a sequence of image lines or scan lines arranged one below the other and numbered from top to bottom, the top line being numbered one. Each line consists of a sequence of elements or pixels arranged across the line and numbered left to right, the leftmost element being numbered one. This coordinate system is independent of McIDAS and forms the basis for most manipulation of the image data by McIDAS.

Image Frame A digital area transferred to the TV refresh memory is displayed on an image frame. The number of image frames varies from terminal to terminal, depending upon the hardware configuration.

Image Sector A portion of the total satellite image extracted from the original digital data transmitted by the satellite. This is accomplished by starting at some arbitrary point of the original image and sampling and/or averaging down and to the right. "Image sectors" or "digital areas" or "areas" are used interchangeably in McIDAS documents.

Initiator A component of the IBM operating system that starts McIDAS functions. Each McIDAS command is read by an initiator which executes a McIDAS program. Fifteen initiators are available. In order for a program to execute it is necessary for it to hold one initiator until execution has completed. Each terminal can use up to four at any given time. If none are available you will need to wait for your turn before your program will run. You can list the initiators in use with command SS.

IR Stands for Infrared. IR data represents the emitted longwave (infrared) radiation from the earth. On satellite images the colder temperatures on a TV image show up whitest while the warmest areas are dark gray.

Joystick A special purpose input device used to indicate to the system where the cursor should be placed on the TV screen. Two joysticks are supplied with each terminal.

The right hand one causes large scale movements of the cursor and the left moves the cursor proportionately smaller distances.

- Keywords** When used in a command format, as input, keywords are always followed by equals (=) or a comma (,). The left hand side of the equal sign is the name of the keyword which the McIDAS function looks for. The right side is the numeric value or word you want to assign to that keyword. Keywords are always optional in a command and can be omitted or given in any random order.
- Level** Eight cursor and graphic color levels are available on each terminal. Each level has the ability to maintain and display a color taken from the color pallet which can be displayed or changed by command CS.
- Line** A sequence of lines, arranged one below the other and numbered from top to bottom, the top line being number one.
- LOGOFF** Command used to end your terminal session. No additional commands may be entered nor charges incurred until the terminal is logged back on.
- Log On** You must Log on to start a terminal session. Entering your initials and project number causes the computer to "wakeup" and begin accepting McIDAS commands. User charges begin accumulating after logging on.
- Looping** The automatic stepping through of a sequence of image or graphic frames. The image and graphic frames are arranged in a circular fashion, like a side projector carousel. When the end of the loop is reached the system moves to the first frame in the loop in a circular fashion.
- LW Files** Stands for "Long Word array". LW is used as a prefix to the names of all the basic level disk file routines.
- Macro** An executable command program typically used to simplify the execution of frequently repeated tasks or processing steps. Macro language allows standard Fortran statements to be mixed with McIDAS commands in defining another command.
- McIDAS** Man-computer Interactive Data Access System.
- MD File** Stands for Meteorological Data file system. It is a generic file for single location observations (non-image) designed to accomodate many different types of data under one generalized structure. MD files look like a large 2-dimensional matrix of data records.

The records are addressed by 2-d coordinates, the upper-left-most record being (1,1), row 1 and column 1.

Mercator

A map projection in which meridians and parallels of latitude appear as lines crossing at right angles.

Navigation

The determination of a set of variables necessary for the transformations between an earth based coordinate system (latitude,longitude) and a satellite based coordinate system (line,element).

Opposite Frame

The image frames on a terminal are grouped in pairs. A frame is grouped with its opposite. The opposite of any frame is always half the total number of frames away and can be found by striking the F key. An opposite image frame can be overlayed on the presently viewed image frame using pseudo coloring techniques.

Pictel

Refers to TV coordinates in the left-right direction. The pixels on a TV monitor are numbered by pictel columns (horizontal) starting at the left of the screen(range 1 to 640).

Pixel

An image element assigned a unique pair of integers in the TV coordinate system.

Positional Parameters

Numbers or words given to McIDAS commands by the user following the command name. Their order of input has to be entered as specified in the Users Manual. They are used as command input in one of three ways: 1) Type in the parameter as is described in the Users Manual, in uppercase (e.g. SAT,INI,MSN); 2) type in the requested alpha-numeric string; 3) fill in the position with an 'X' and the default value is used for that parameter.

Project Number

Each user, or group of users, are assigned a project number by SSEC. This is a 4-digit number used when logging onto McIDAS for assigning digital areas, McIDAS user charges, and other system related services.

Pseudo Coloring

Refers to the ability to redefine the relationship between the brightness or color of a pixel of digital data and the pixels digital value. These gray scale or color enhancements do not alter the digital data stored on disk, only the video image is temporarily modified.

Purge

All areas, grid files, MD files, LW files, navigation files, and occasionally old string tables are deleted from McIDAS on the first of every month. If you need any of this data saved you are responsible for submitting a request by the evening prior to the system purge.

Raster	The top to bottom coordinate on the TV screen which is also called the "TV line". Its range is 1 to 480. Rasters and pictels refer to TV coordinates.
Refresh Memory	To make an image or graphic plot visible on the TV screen, the TV must be continuously fed with an image, (refreshed). This is the function of the refresh memory. It is the storage medium for both the graphic and image frames. This memory is divided up into frames.
Resolution	Refers to the image space represented by a TV pixel. An image frame of resolution four means that a box of four by four image pixels are represented by a TV pixel.
Row	The vertical coordinates referred to in MD files.
Schema	The format for the fields or variables in MD files. These names are recorded in a list called a file schema. This defines a blueprint for all MD files of a given type.
Stereo	The display of separate images for left and right eyes to create a 3-dimensional illusion. Usually the two images are displayed in red and green, and viewed through red and green glasses. True stereo display is obtained from simultaneous display of two separate images of the same geographical area obtained from two satellites at different observing positions such as the GOES East and West satellites. The resulting images, color enhanced, viewed with red-green glasses, appear to be three dimensional. False stereo is created from a visible image so that the apparent parallax of the visible clouds is proportional to the cloud top altitudes estimated from the infrared cloud temperature data. Simultaneously displayed in red and green, the real visible image and offset one create an illusion of stereo.
String Table	A table of named character strings which the user can define with the command TE, and which can be accessed by programs using parameter fetching subprograms. It has two uses; the first use is to provide a shorthand method of entering commands, the second is to allow programs to access keyword values which have been predefined by the user and which are not actually keyed in when the program is invoked.
System Status	Lists the current state of executing McIDAS commands. Command SS, ST, or SST will list the currently executing programs and their corresponding terminal numbers, user IDs, project numbers, initiator numbers, and CPU cycles.

Toggle Refers to the turning on and off of graphic or image frames. Similar to turning on and off a light switch.

TV Coordinates The pixels of a TV screen are numbered by raster line (vertical) starting from the top of the screen, and by pictel, (horizontal) starting at the left of the screen. The pixel in the upper left hand corner of the screen is numbered (1,1). The total number of raster and pictels vary between terminals. Generally the lower right hand corner of the screen is (480,640).

Visible Visible satellite imagery, when displayed on McIDAS, appears as a gray scale image. It is an image of reflected sunlight, (only available during the daylight hours) representing exactly what your eye would see from the satellite's position.

WRRRM Each video terminal is provided with a number of graphics overlay memories called "Write Random Read Raster Memory". The contents of a WRRRM, loaded with graphics data, can be displayed on the TV screen along with the image frame and cursor.