

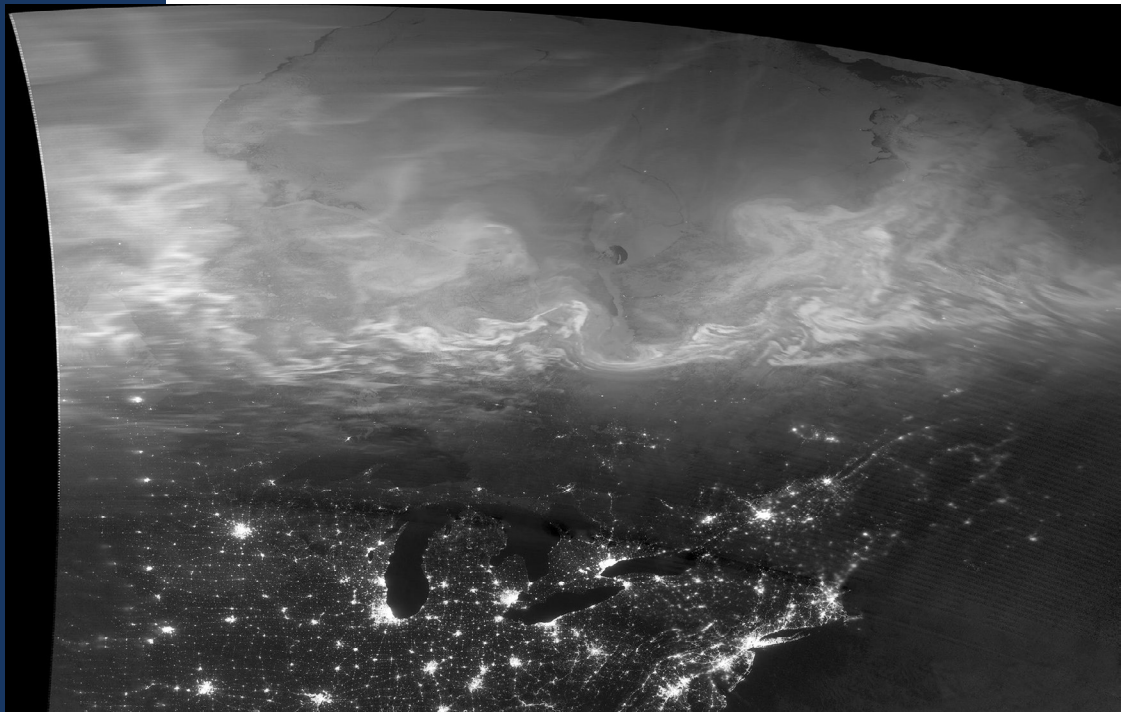

# CIMSS Cooperative Agreement Annual Report

for the period  
1 April 2017 to 31 March 2018



NOAA-20  
Aurora  
Borealis

Submitted by the  
Cooperative Institute for  
Meteorological Satellite Studies  
University of Wisconsin-Madison  
April 2018



**University of Wisconsin–Madison**

**Cooperative Institute for  
Meteorological Satellite Studies (CIMSS)**

<http://cimss.ssec.wisc.edu/>

---

# **Cooperative Agreement Annual Report**

**for the period**

**1 April 2017 to 31 March 2018**

**Cooperative Agreement Number: NA15NES4320001**

**Submitted to:  
National Oceanic and Atmospheric  
Administration  
(NOAA)**



# Cooperative Agreement Annual Report from the Cooperative Institute for Meteorological Satellite Studies University of Wisconsin–Madison

1 April 2017 to 31 March 2018

**Steven A. Ackerman**  
Principal Investigator, CIMSS

**Wayne Feltz**  
Executive Director-Science, SSEC

## CIMSS Contributing Task Leaders

Ackerman, Steve  
Batzli, Sam  
Borg, Lori  
Botambekov, Denis  
Calvert, Corey  
Cintineo, John  
Davies, James  
Feltz, Wayne  
Foster, Michael  
Garcia, Ray  
Gerth, Jordan  
Gravelle, Chad  
Gumley, Liam  
Gunshor, Mat  
Hoffman, Jay  
Huang, Hung Lung (Allen)  
Hubbard, Shane  
Jasmin, Tommy  
Jung, James  
Knuteson, Robert  
Lee, Yong-Keun  
Lenzen, Allen  
Li, Jun  
Lim, Agnes  
Lindstrom, Scott  
Liu, Yinghui  
Martin, Graeme  
Menzel, W. Paul  
Moeller, Chris  
Mooney, Margaret  
Olander, Tim  
Otkin, Jason  
Rink, Tom  
Santek, Dave  
Schmidt, Chris  
Sieglauff, Justin  
Strabala, Kathleen  
Straka, William

Taylor, Joe  
Tobin, Dave  
Velden, Christopher  
Wagner, Tim  
Walther, Andi  
Wanzong, Steve  
Weisz, Elisabeth  
Wimmers, Anthony

## ASBP/NCDC Collaborators

Heidinger, Andy  
Key, Jeff  
Pavolonis, Mike  
Pierce, Brad  
Schmit, Tim

## Additional Contributors

Avila, Leanne  
Hackel, Jenny  
Phillips, Jean  
Vasys, Maria



## Table of Contents

<b>I. Director’s Executive Summary</b> .....	<b>15</b>
<b>II. Background Information on the Cooperative Institute for Meteorological Satellite Studies (CIMSS)</b> .....	<b>17</b>
1. Description of CIMSS, including research themes, vision statement and NOAA research collaborations .....	17
2. CIMSS Management and Administration .....	18
3. Summary of NOAA Funding to CIMSS in FY2017.....	19
<b>III. Project Reports</b> .....	<b>23</b>
1. CIMSS Task 1A Support .....	23
2. CIMSS Task 1B Support – Education and Public Outreach.....	24
3. CIMSS Participation in the Product Systems Development and Implementation (PSDI) for 2017.....	28
3.1 JPSS PSDI: VIIRS Polar Winds.....	28
3.2 GEO PSDI: Enterprise Processing Ground System – Fog and Low Cloud Products .	29
3.3 Blended Advanced Dvorak Technique (ADT) Upgrades .....	32
3.4 JPSS Cal/Val Support – Volcanic Ash EDR.....	33
4. CIMSS Participation in the GOES-R Algorithm Working Group (AWG) in 2017-2018 ....	34
4.1 Algorithm Integration Team Technical Support .....	34
4.2 ABI Cloud Products .....	36
4.3 Active Fire/Hot Spot Characterization .....	46
4.4 GOES-R Legacy Atmospheric Profile (LAP), Total Precipitable Water (TPW), and Atmospheric Instability Indices.....	48
4.5 ABI Derived Motion Winds .....	51
4.6 Hurricane Intensity Estimation (HIE) Algorithm.....	52
4.7 Volcanic Ash .....	53
4.8 Imagery and Visualization.....	55
4.9 Estimate of Fractional Snow Cover with ABI.....	57
4.10 GOES-R Support for International TOVS Study Conference ITSC-21.....	59
5. CIMSS Support to GOES-R NOAT Priority Research Risk Reduction.....	61
5.1 GOES-R Future Capability: SO <sub>2</sub> Detection .....	61
5.2 GOES-R Future Capability: Continued Development of the GOES-R AWG Fog/Low Cloud Products .....	64
5.3 Evaluation of Turbulence-Detection Methods on Himawari-8 .....	68
5.4 Severe Storms Component of the GOES-R High-Impact Weather Theme .....	70
5.5 ProbSevere: Train ProbSevere with GOES-16 Data .....	76
6. CIMSS GOES-R Risk Reduction Program New 2017-2018.....	79
6.1 Integration of GOES-R/ABI data in Flood Mapping Software for Flood Monitoring and Forecasting.....	79
6.2 ProbSevere: Upgrades and Adaption to Offshore Thunderstorms .....	80
6.3 Improving the Assimilation of High-Resolution GOES-16 Water Vapor Variables and Atmospheric Motion Vectors in the HWRf Model .....	83
6.4 Assimilation of High Resolution GOES-R ABI Infrared Water Vapor and Cloud Sensitive Radiances using the GSI-based Hybrid Ensemble-variational Data Assimilation System .....	87



6.5 Using Multi-sensor Observations for Volcanic Cloud Detection, Characterization, and Improved Dispersion Modeling.....	88
6.6 Development of GOES-R IR Clear-Sky and All-Sky Radiance Products for NCEP ..	92
7. CIMSS Participation in the Development of GOES-R Proving Ground in 2017-2018.....	94
8. CIMSS Collaboration with the NWS Operations Proving Ground .....	104
9. CIMSS Support for High Impact Weather Studies with GOES-16 ABI and JPSS Advanced IR Sounder Data .....	106
10. CIMSS Support to GOES-R SHYMET, Mcidas-V, and Program Support Tasks.....	112
10.1 CIMSS Participation in SHyMet for 2017 .....	112
10.2 Senior Scientist Support of the GOES-R Program Office .....	114
10.3 McIDAS-V Support for GOES-R .....	117
11. Development of a Geostationary Community Satellite Processing Package (CSPP) / Supplemental Tasks .....	119
12. GOES-R Specific Mobile Apps .....	123
13. CIMSS Support to Participate in GOES-R Visiting Scientist Program 2017 .....	125
13.1 Development of Advanced Data Assimilation Techniques for Improved use of Satellite-Derived Atmospheric Motion Vectors in Hurricane Forecasting .....	125
13.2 Exploring Innovative Ways to Use Satellite Observations to Verify the Accuracy of Numerical Weather Prediction Model Forecasts.....	126
14. Development of an Archival System for the Integration of High Resolution GOES-R, Radar, and Lightning Data for Improving Severe Weather Forecasting and Warning Capabilities.....	130
15. SSEC/CIMSS Cloud Research in Support of the Suomi-NPP and JPSS Programs 2017 ..	132
15.1 VIIRS Algorithm Development .....	132
15.2 Software/Algorithm Integration and Testing.....	134
15.3 Software/Algorithm Maintenance .....	136
15.4 Calibration and Validation .....	139
15.5 Long-Term Monitoring and Anomaly Resolution .....	141
15.6 McIDAS Support for VIIRS Imagery and Data Analysis.....	143
16. SSEC/CIMSS Research Tasks in Support of the SuomiNPP and Joint Polar Satellite System (JPSS) Sensor Data Records.....	145
16.1 A Broad Scope of Calibration/Validation and Independent Verification and Validation Activities in Support of JPSS, with Emphasis on CrIS SDRs.....	145
16.2 VIIRS SDR Calibration/Validation.....	151
17. SSEC/CIMSS Research Tasks in Support of SuomiNPP and the Joint Polar Satellite System (JPSS) Sounding and Cyrosphere Environmental Data Records (EDR) .....	158
17.1 CrIMSS EDR Cal/Val: ARM Site Support 2017 .....	158
17.2 Science and Management Support for NPP VIIRS Snow and Ice EDRs.....	160
18. CIMSS Participation in the JPSS Proving Ground/Risk Reduction Program.....	166
18.1 Advancing Hyperspectral Sounder Applications in the Direct-Broadcast Environment .....	166
18.2 Enhance the Utilization of Real Time JPSS Sounder Data in SDAT for Tropical Cyclone Forecast Application .....	169
18.3 High Resolution Trajectory-Based Smoke Forecasts using VIIRS Aerosol Optical Depth and NUCAPS Carbon Monoxide Retrievals .....	173
18.4 The Cold Air Aloft Aviation Hazard: Its Detection Using Observation from the JPSS	176
18.5 A Fused SO <sub>2</sub> Analysis from JPSS .....	178
19. CIMSS Participation in the 2017 JPSS Proving Ground/Risk Reduction Program.....	181
19.1 Addressing NWS Desires for Cloud Cover Layers (CCL) and Sky Cover Products using VIIRS and CrIS.....	181



19.2 Strengthening TPW visualization in the OCONUS domain with JPSS data products	183
19.3 Application of JPSS Imagers and Sounders to Tropical Cyclone Track and Intensity Forecasting .....	187
19.4 Further Development of the VIIRS Nighttime Lunar Reflectance-Derived Cloud Properties and the Demonstration of their use for Precipitation and Icing Applications	188
19.5 CIMSS Support to In Pursuit of the Shadows: VIIRS Day/Night Band Research Enabling Scientific Advances and Expanded Operational Awareness of the Nocturnal Environment for 2017-2018 .....	190
20. GeoNetCast Americas System Development and Users’ Support.....	193
21. CIMSS Support to the Development of a Community Satellite Processing Package (CSPP) for SuomiNPP/JPSS Real Time Regional Applications for 2017.....	195
21.1 CSPP Level 2 Software Enhancement and Support.....	195
21.2 DB Real Time Network Operations, Monitoring, and Processing.....	198
21.3 Enhancement of CSPP Polar2Grid Software for Real-Time Imagery delivery to the National Weather Service.....	200
21.4 Maintenance/Enhancements to RealEarth and ISEE/JPSS App Completion.....	202
21.5 Maintenance and Enhancements to the River Ice and Flood Products .....	204
21.6 CSPP Training and Outreach .....	205
21.7 CIMSS Support for ITSC and CSPP/IMAPP Users Group Meeting.....	206
21.8 JPSS Science and Innovations.....	208
22. CIMSS Support to the JPSS Algorithm Development Library Team for 2017.....	210
23. CIMSS Ongoing Investigations in Support of the JPSS Program Office 2017 .....	211
24. Implementation of GCOM-W1 AMSR2 Snow Products.....	215
25. Support CIMSS JPSS and AWIPS II OCONUS Satellite Liaison .....	218
26. CIMSS Support to JPSS Field Terminal Segment (FTS) Tasks 2017 .....	220
27. CIMSS Participation in the Evaluation on the Alternative of Advanced IR and MW Sounders with CIRAS and MicroMAS-2 for Weather Forecasting through OSSE .....	223
28. CIMSS Support for NPP and JPSS Data Assimilation Improvements and Data Denial Experiments.....	229
29. CIMSS Cal/Val Activities in Support of the Calibration Work Group .....	231
30. CIMSS Support to GOES-R Calibration/Validation Deployment Support For Scanning HIS (S-HIS) .....	233
31. CIMSS Support to Participate in Enhanced Measurements During GOES-R Post Launch Testing for ABI Baseline and Future Project Validation 2017 .....	235
31.1 SPARC Deployment to Sheboygan, WI, for GOES-16 Level Validation During 2017 Lake Michigan Ozone Study (LMOS) .....	235
31.2 GOES-16 Level 2 Cryosphere Validation in Green Bay.....	237
32. CIMSS Participation in Sensing Hazards with Operational Unmanned Technology (SHOUT).....	239
33. RTAP Reduced Chemistry Model Integration.....	242
34. CrIS/OMPS and TES Ozone Retrievals in Support of the FIREX Intensive Campaign ...	243
35. GOES-S Teacher Workshop at Lockheed Martin.....	245
36. CIMSS Support to GOES-16 ABI Weighting Function Training for Operational Users..	248
37. GOES-R Education Proving Ground .....	250
38. ABI Short Courses (CIMSS Support to the GOES-R Program).....	253
39. CIMSS Research Activities in the VISIT program in 2017-2018 .....	254
39.1 CIMSS Support for Satellite Training Activities for the VISIT Program.....	254
39.2 CIMSS Support to Develop of the Satellite Information Familiarization Tool to Support the National Weather Service Training Program.....	257
40. CIMSS Support for GOES-R ABI Trainings (CIMSS Support to GOES-R Program) .....	260



**Appendix 1: List of Awards to Staff Members .....262**  
**Appendix 2: Publications Summary .....263**  
**Appendix 3: Employee Support Documentation .....265**  
**Appendix 4: Research Topics of Current CIMSS Graduate Students and Post-Doctors ...266**  
**Appendix 5: Visitors at CIMSS 2015-2016 (visits of 3 days or more and key visitors) .....270**  
**Appendix 6: List of Staff/Students hired by NOAA in the past years .....272**  
**Appendix 7: CIMSS Board of Directors and Science Council .....273**  
**Appendix 8: CIMSS Publications, 2015-2018 .....275**



## Figures

Figure 1. CIMSS student group visiting NWSFO MKX. ....	25
Figure 2. GOES-S Teachers at Lockheed Martin, posing in front of the GOES-S satellite. ....	26
Figure 3. September 2017 tweet via @UWCIMSS. ....	27
Figure 4. The GOES-R IFR probability product applied to a GOES-16 full-disk scene from April 1, 2018 at 23:23 UTC produced by the SAPF. ....	31
Figure 5. The attributes diagrams for the GOES-NOP version of the GOES-R IFR probability product, applied to GOES-13, produced from the NOAA/NESDIS operational STAR Algorithm Processing Framework (SAPF) for daytime (solar zenith angle < 80°), terminator (solar zenith angle between 80°-90°) and nighttime (solar zenith angle > 90°) pixels. These diagrams include pixels composed of both water and ice. Points that lie within the shaded region indicate that the model has skill over climatology. This analysis shows that the GOES-R IFR probabilities being transitioned to NOAA/NESDIS operations are generally well calibrated. Over 1,000,000 surface observations from all 12 months of 2016 were used in this analysis. ....	32
Figure 6. Example baseline GOES-16 ABI RGB (left) and BCM (right) on March 3, 2017 at 1925 UTC. ....	37
Figure 7. Cloud Top Phase example from April 18, 2017 at 19:00 UTC. ....	38
Figure 8. GOES-R Cloud Top Phase validation compared to the CALIOP cloud top phase product, as a function of cloud optical depth obtained from CALIOP. The horizontal black line represents the accuracy requirement defined by the ABI RIMP. ....	39
Figure 9. CTP examples from April 18, 2017 at 19:00 UTC. CTH left, CTp middle, and CTT right. ....	40
Figure 10. COD examples from DCOMP on January 24, 2018 at 17:00 UTC and NCOMP on January 12, 2018 at 08:00 UTC. ....	41
Figure 11. CPS examples from DCOMP on January 24, 2018 at 17:00 UTC and NCOMP on January 12, 2018 at 08:00 UTC. ....	41
Figure 12. Comparison of status at Beta vs Provisional Maturity. Top row: ABI bands; Middle: A) Old ground system output mask, B) Old CIMSS output mask, C) Provisional maturity output mask; Bottom: Bkg calc pixels before/after fix. ....	48
Figure 13. TPW from both GOES-16 and GOES-15 (left panel: GOES-16 full disk; right panel: GOES-16 CONUS) for 10 UTC 2017.11.03 (307). ....	50
Figure 14. Scatter plots (top; ash height left, ash mass loading right) and difference histograms (bottom; ash height left, ash mass loading right) for 15 manually analyzed volcanic ash clouds from the Popocatepetl volcano during November 2017. The two data sources are the GOES-R Ground System and locally run GEOCAT implementations of the GOES-R Volcanic Ash algorithm. ....	54
Figure 15. First GOES-16 ABI 16-panel image of all bands after GOES-16 became operational GOES-East on December 18, 2017 at 17:30 UTC. ....	56
Figure 16. GOES-16 Fractional Snow Cover daily composite on February 6, 2017 with quality control (left), from IMS (middle), and MODIS false color image (right). ....	58
Figure 17. GOES-16 Fractional Snow Cover daily composite on February 6, 2017 with all quality control within FSC product (left), and with GOES-16 cloud mask and all other FSC quality control without cloud mask quality flag (right). ....	59
Figure 18. An example GOES-16 ABI based VOLCAT SO <sub>2</sub> alert is shown. The alert captures an SO <sub>2</sub> emission from the Fernandina volcano in the Galapagos Islands on September 4, 2017 at 20 UTC. When GOES-16 measurements are used to detect a new volcanic SO <sub>2</sub>	





emission, VOLCAT generates SMS (text message) and email alerts (top images) that contain a hyperlink to an online alert report (bottom images). ..... 63

Figure 19. Attributes diagrams for the GOES-13 (left) and GOES-16 (right) IFR probability products created using 8 days (1 day from each month of March-October 2017) co-located with surface observations of cloud ceiling and surface visibility. Pixels with all solar orientations and cloud types were used to create these diagrams. The diagonal, dashed line bisecting the diagram represents perfect calibration. The diagram for the GOES-16 IFR probability product is noticeably closer to the dashed line confirming that it is more accurately calibrated than the GOES-13 IFR probability product. Similar improvements were seen with the LIFR and MVFR probability products. .... 66

Figure 20. The GOES-16 FLS products are now available in near real-time for NAWIPS (top 4 images) and AWIPS2 (bottom 4 images) via an experimental feed. The MVFR A), IFR (B) and LIFR (C) probability products, along with a visible satellite image (D), are shown above. Configuration information for both NAWIPS and AWIPS2 is provided to ensure the FLS products are properly named, organized and viewed using preferred color tables. .... 67

Figure 21. Screen capture of the gravity wave product turbulence online viewer, showing the North Atlantic from GOES-16. .... 69

Figure 22. Screen capture of the high-pass gravity wave product (upper left) with three other panels of water vapor imagery displayed in AWIPS2..... 70

Figure 23. Plot of AMVs derived from a triplet of multispectral GOES-16 meso sector scan images during Hurricane Harvey (2017). Yellow (Cyan) vectors denote lower (upper) tropospheric flow..... 72

Figure 24. Plot of AMVs derived from a triplet of multispectral GOES-16 meso sector scan images during Hurricane Irma (2017). Yellow (Cyan) vectors denote lower (upper) tropospheric flow..... 73

Figure 25. Plot of AMVs derived from a triplet of multispectral GOES-16 meso sector scan images during Hurricane Maria (2017). Yellow (Cyan) vectors denote lower (upper) tropospheric flow..... 73

Figure 26. The GOES-16 channel 2 VIS imagery of a severe storm on 5 April 2017 over eastern Alabama with an overshooting top. Plotted are AMVs derived from GOES-16 VIS, IR and WV imagery from the NESDIS algorithm and subsequent cloud-top divergence (CTD) analysis (*Left*), and VIS vectors derived with a novel Optical Flow algorithm with CTD (*Right*). CTD is contoured with positive (negative) values in red (blue dash) every  $25 \times 10^{-5} \text{ s}^{-1}$ , and vectors are colored by pressure, with hot pink representing vectors at pressure (p)  $500 \text{ hPa} > p \geq 200 \text{ hPa}$ , cyan at  $200 \text{ hPa} \geq p > 175 \text{ hPa}$ , blue at  $175 \text{ hPa} \geq p > 150 \text{ hPa}$ . .... 74

Figure 27. Example of experimental Saharan Air Layer (SAL) split-window derived imagery from concurrent MSG-SEVIRI (top) and GOES-16 ABI (bottom). The warm colors in the imagery depict dry air and especially dry/dusty air associated with air masses originating over the African Saharan desert. .... 75

Figure 28. The GOES-16 severe and non-severe conditional probability distributions (red and blue lines) with the GOES-16 ratio of these two distributions (solid black lines). The GOES-NOP ratio is also superimposed (dashed black line). The magnitude of the ratio lines indicate how. .... 78

Figure 29. Skill scores, relative to initial local storm report (LSR), for storms that were well observed by GOES measurements from an early stage of development. A probability threshold of 80% was utilized. Note that the GOES-16 version (orange bar) of ProbSevere adds 4 minutes of lead-time compared to the corresponding GOES-NOP version (yellow bar)..... 78



Figure 30. Example ABI flood product from 31 Aug 2017 showing flooding in South Texas after Hurricane Harvey. .... 80

Figure 31. Skill scores, relative to initial local storm report (LSR), for storms that were well observed by GOES measurements from an early stage of development. A probability threshold of 80% was utilized. Note that the GOES-16 version (orange bar) of ProbSevere adds 4 minutes of lead-time compared to the corresponding GOES-NOP version (yellow bar)..... 82

Figure 32. The distribution of GOES-16 ABI-derived cloud vertical growth rates for over 300,000 vertically growing clouds. The vertical blue dashed lines indicate number of standard deviations above the mean (2 standard deviations above the mean on the right to 10 standard deviations above the mean on the left). The vertical growth rate distribution accounts for initial state of each cloud feature being tracked. .... 82

Figure 33. Data assimilation and forecast experiment schemes for hurricane Harvey (2017)..... 85

Figure 34. The mean HT (km) (upper) and SLP (hPa) (lower) RMSE from control run and the three assimilation experiments for Hurricane Harvey (2017). .... 86

Figure 35. A GOES-16 VOLCAT alert for a Popocatepetl (Mexico) ash emission on July 7, 2017 is shown in the top panel. The volcanic ash advisory, issued by the Washington Volcanic Ash Advisory Center (VAAC), is also shown. This particular ash emission was not easily identifiable in GOES-13 or GOES-15 imagery. As indicated in the red box, this volcanic ash advisory was a direct result of the GOES-16 VOLCAT alert. This and many other cases illustrate the operational value of VOLCAT alerts and products. VOLCAT alerts are routinely cited by VAAC’s..... 90

Figure 36. An automatically generated time series of total volcanic cloud area (black line) and total mass of ash (gray line) following the February 11, 2010 lava dome collapse at Soufriere Hills (Montserrat). The time series was derived from Meteosat Second Generation SEVIRI data, which has comparable capabilities as the GOES-R ABI (a GOES-16 ABI case is not shown because GOES-16 has not yet observed a significant explosive eruption). The time evolution of volcanic cloud area can be used to estimate mass eruption rate, which is a critical parameter needed to constrain dispersion models. The total mass of ash acts as an additional constraint. Automated derivation of time series, such as the one shown above, is a “one of a kind” capability. .... 91

Figure 37. Departure statistics for channel 14, 11.2 μm observed brightness temperature minus the GDAS simulated brightness temperature (first guess) as a function of the standard deviation of the clear pixels within the processing box. Data are limited to ocean points with sensor zenith angles less than 60°. Three processing box sizes are shown..... 94

Figure 38. Seven groups of the 120-hour forecasts for Hurricane Joaquin (2015) after assimilation of CrIS CCRs. Black: best estimate (observations); Bule: using conventional data from GTS, 4 AMSU-A and ATMs; Red: conventional data, 4 AMSU-A, ATMS and CrIS clear radiances (GSI approach); green: same as red but using CrIS CCRs instead of CrIS clear radiances only..... 109

Figure 39. Forecasts from HWRF/Op (upper left), HWRF/S4 (upper right) for hurricane Irma (2017), along with track and intensity forecast statistics against best track estimate (cntl is the results from HWRF/S4, avno is the results from GFS). .... 110

Figure 40. The track (upper) and SPD (lower) forecast RMSE from control run (blue) and the other three experiments, for Hurricane Harvey (2017) forecasts. .... 111

Figure 41. GIIRS Spectra for various standard atmospheres. .... 116

Figure 42. Jan 2018 Remote Sensing Seminar attendees. .... 116

Figure 43. University of Chicago Press description of Suomi Book. .... 117

Figure 44. California wild fire event near the time of some of the most extreme Santa Ana wind gusts, Dec 5 to 6. Parcel trajectories, rendered as red cylinders, initialized in the boundary



layer for a set of points over the Great Basin, and propagated forward with a 24hr, NAM 4km forecast starting at 18Z. The color shaded field (low, yellow to high, blue) is 1000mb Relative Humidity. .... 118

Figure 45. CSPP Geo processing chain for GOES-16 GRB. .... 120

Figure 46. Quicklook images showing examples of Level 2 products generated by the AIT Framework package running on ABI data received via GRB. .... 122

Figure 47. These screenshots show the GOES App in the iOS and Google Play stores. .... 124

Figure 48. Enterprise Cloud Mask (ECM), NOAA-20 VIIRS, 2018-03-31. (These NOAA-20 data are preliminary, non-operational data and are undergoing testing. Users bear all responsibility for inspecting the data prior to use, and for the manner in which the data are utilized). .... 133

Figure 49. Sample of ECM (VCM) Manual Analysis Tool. .... 134

Figure 50. Processing time in number of hours to process a day of VIIRS data as a function of processing cores. .... 136

Figure 51. Histogram Distribution of differences between NPP VIIRS and CALIPSO/CALIOP. Phase matching and single layer filtering is applied. One day data (01/03/2015) are used. .... 137

Figure 52. Scatter plots of phase-matched single layer cloud top heights between CALIPSO/CALIOP and SAPF (up) and CLAVR-x (bottom). Same data are used as in Figure 51. The red line is the specification requirement from JPSS L1RD. .... 138

Figure 53. Scatter plots of cloud base heights between VIIRS from SAPF and CloudSat. Only pixels with CTH within 1km of CloudSat CTH if COT > 1, or within 2km if COT < 1 are included. .... 139

Figure 54. a) SNPP-VIIRS RGB, b) SNPP-VIIRS Cloud Optical Depth (COD), c) Aqua-MODIS COD. .... 141

Figure 55. Example of the imagery delivered to NOAA/NESDS/STAR for monitoring. This and other imagery can be found at [http://www.star.nesdis.noaa.gov/jpss/EDRs/products\\_clouds.php](http://www.star.nesdis.noaa.gov/jpss/EDRs/products_clouds.php). .... 143

Figure 56. NOAA-20 VIIRS RGB, rendered via a McIDAS-V background script. .... 144

Figure 57. JPSS-1 CrIS thermal vacuum results comparing the calibrated radiance of each OFV against the "known" brightness temperature of the External Calibration Target (ECT). Without radiometric nonlinearity corrections. .... 147

Figure 58. The same as Figure 57 but including radiometric nonlinearity corrections, and with nonlinearity coefficients (a2) tuned to give optimal agreement with the ECT view radiance. .... 147

Figure 59. JPSS-1 nonlinearity coefficients, a2, for the LW (top panel) and MW (bottom panel) FOVs/detectors. .... 148

Figure 60. Earth view brightness temperature differences from the LW reference FOV6 for JPSS-1 CrIS LW detectors/FOVs. The red, green, and blue residuals correspond to the sets of a2 values shown in Figure 59. .... 149

Figure 61. The same as Figure 60 but for the MW band and using MW reference FOV5. .... 149

Figure 62. JPSS-1 CrIS radiance data collected during the 31 January 2018 pitch maneuver. Left panel: time series of the LW window radiance for different scan view angles (FORs). Right panel: LW window radiances as a function of time and FOR (scan angle) when viewing deep space. .... 150

Figure 63. Time series of VIIRS-CrIS comparisons for SNPP and NOAA-20 (upper and lower left, resp.). VIIRS-CrIS comparisons as a function of scene temperature (upper and lower right). .... 153

Figure 64. VIIRS-CrIS comparisons as a combined function of scan angle and scene temperature for SNPP (left) and NOAA-20 (right). .... 154



Figure 65. The (a) daily and (b) weekly time series of M07 reflectance modes (dashed lines) and means (solid lines) of DCCs selected by BNR > 1 (red) and M15 BT (blue) of JJA season of 2017. The reflectance Mean and Mode of JJA's, as well as the standard deviation (STD, unit: %) and the variation range (VAR, unit: %) of time series of DCC reflectance means and modes are calculated and shown in texts above each panel. .... 156

Figure 66. VIIRS IST (red), IDPS IST (green), and IceBridge P3 KT-19 IST (black) for all coincident IceBridge flights with cloud-free observations over the Arctic in 2015..... 161

Figure 67. Differences between NPP VIIRS and MODIS (Aqua and Terra) IST in the Arctic for all cases from August 2012 to July 2015. .... 162

Figure 68. Daily composites of S-NPP VIIRS Ice Surface Temperature using the Enterprise algorithm. Left: 1 April 2016; right: 6 April 2016. IST was in the range of 245-265 K on 1 April, warming to 255-275 K by 6 April, probably caused by a strong ridge of high pressure developed over Greenland, allowing warm air from the south to be advected over the Baffin Bay region. .... 162

Figure 69. (left) Ice concentration (IC) derived from the Landsat image (30 m resolution); and (right) the calculated IC using the Suomi NPP VIIRS. White areas denote pixels flagged out as either land or cloud. .... 163

Figure 70. Statistical results of the comparison in sea ice thickness between S-NPP (OTIM) and NASA IceBridge (aircraft lidar + snow radar) for matched locations. .... 165

Figure 71. (a) NUCAPS (left) and Dual-Regression (right) derived dewpoint temperature at 500 hPa. (b) Skew-T plots of a radiosonde observation (RAOB) at Lamont, OK at 1800 UTC on 11 May 2015 (black), co-located NUCAPS (red) and Dual-Regression (blue, left panel) and DR+De-Aliasing (DA) retrievals (blue, right panel). .... 167

Figure 72. Lifted Index derived from polar hyperspectral soundings (left) and from a combination of the PHS and GOES-16 ABI data (right) for 19 May 2017 (~1500 UTC). .... 168

Figure 73. Seven groups of the 120-hour forecasts after re-run on assimilation of reprocessed CrIS CCRs with refined algorithm. Black: best estimate (observations); Blue: using conventional data from GTS, 4 AMSU-A and ATMs; Red: conventional data, 4 AMSU-A, ATMS and CrIS clear radiances (GSI approach); green: same as red but using CrIS CCRs instead of CrIS clear radiances only. .... 171

Figure 74. AC for 250 hPa from parallel GFS experiments on CrIS radiance and CCR assimilation (Figure from EMC). .... 172

Figure 75. The CrIS CCRs assimilated into HWRF and the original CrIS radiances assimilated into HWRF (Hurricane Irma case) for channel 96 (14.10 μm). .... 173

Figure 76. 24hour forecast for VIIRS High Resolution trajectories over the NE US initialized on September 04, 2017. .... 175

Figure 77. Real-time SNPP NUCAPS CO Trajectories initialized on March 27, 2018 (left panel) and 10 hour forecast valid at 18Z (right panel) on March 27, 2018. .... 175

Figure 78. A sample SO<sub>2</sub> alert from the NOAA/CIMSS Volcanic Clouds webpage (<http://volcano.ssec.wisc.edu>), produced by the VOLCAT system and captured by the SNPP VIIRS instrument. This alert shows an SO<sub>2</sub> plume emanating from the Fernandina volcano in the Galapagos Islands (yellow/green cloud in the left false color imagery, encapsulated by the automated blue polygon). Users are sent the alert link via email or SMS (text messaging). .... 180

Figure 79. VIIRS granule on August 26, 2015 at 2004 UTC shows false color RGB (upper left), 11 μm brightness temperature (upper right), cloud type (bottom left) and cloud top height (bottom right). .... 182

Figure 80. Same VIIRS granule as in Figure 79 shows supercooled water cloud fraction at each Flight Level (FL) and the total supercooled fraction (bottom right). The FL is indicated for each image. .... 183



Figure 81. Screenshot of the RealEarth website with MIMIC-TPW2 and GOES-16 infrared window layers..... 185

Figure 82. Demonstration of 12-hour trajectories in the North Pacific and Alaska. The four layers are indicated by color -- Yellow: 300-500 hPa, Green: 500-700 hPa, Blue: 700-850 hPa, Black: 850 hPa - surface..... 186

Figure 83. SATCON MSW plot compared to recon-aided best track (working) for Hurricane Maria in 2017. .... 188

Figure 84. Illustration of precipitation retrieval output..... 190

Figure 85. DNB and I04 satellite images from SNPP of the wildfires in Portugal. Image is from SNPP, from 18 June 2017 and ~0240 UTC. .... 191

Figure 86. Example of annotated imagery from 12 September 2017 provided to emergency response stakeholders. .... 192

Figure 87. Schematic diagram of a typical GEONETCast-Americans station required to receive GEONETCast data/products. .... 194

Figure 88. Composite Sea Surface Temperature ACSPO retrieval image as displayed in AWIPS. The composite consists of 8 different VIIRS, MODIS and AVHRR overpasses acquired and processed using the CSPP Polar2Grid software at Hampton University during one 12 hour period. .... 201

Figure 89. Left: ISEE/JPSS App in the Android Store. Right: ISEE/JPSS App in the iOS Store. .... 203

Figure 90. User-defined notifications (in this case, JPSS-detected flooding) can be synchronized between ISEE web browser and ISEE mobile App. When an event triggers a notification, the user can then share it with social media. .... 203

Figure 91. JPSS Flood Product example after Hurricane Harvey in Real-Earth from Aug 31, 2017. .... 205

Figure 92. Wind speed (left) and wind direction (right) comparisons between analysis with and without ABI proxy radiances and the co-located dropwindsonde observations (upper panel) and difference/error (lower panel)..... 209

Figure 93. HIRS-IASI TPW for 15 Dec 2012 (top) and HIRS minus HIRS-IASI TPW difference (bottom). .... 214

Figure 94. HIRS-CrIS TPW for 15 Dec 2012 (top) and HIRS minus HIRS-CrIS TPW difference (bottom). .... 214

Figure 95. Snow detection accuracy. Overall accuracy (overall) is the number of pixels where both AMSR2 and IMS detect snow or no-snow divided by the total number, where the total number is the sum of valid AMSR2 pixel numbers for snow detection test. Snow detection rate (snow detect) is the number of pixels where both AMSR2 and IMS detect snow divided by the number of pixels where IMS detects snow. Omission error (omission) is the number of pixels where AMSR2 misses snow divided by the total number. Commission error (commission) is the number of pixels where AMSR2 incorrectly detects snow divided by the total number. .... 217

Figure 96. Flowchart of the quick R-OSSE..... 224

Figure 97. The final RMSE for the four experiments of MicroMAS-2. GAP assimilates RAOB, AMSU-A and IASI from Metop-B. CNTL assimilates everything from GAP plus ATMS. MO1 assimilates everything from GAP plus MicroMAS-2 with 1:30 pm orbit. And MO2 assimilates everything from GAP plus 3 MicroMAS-2 with 10:30 am, 1:30 pm, and 4:30 pm orbits..... 226

Figure 98. The final RMSE for the four experiments of CIRAS. GAP assimilates RAOB, AMSU-A and IASI from Metop-B. CNTL assimilates everything from GAP plus CrIS. MO1 assimilates everything from GAP plus CIRAS with 1:30 pm orbit. And MO2 assimilates everything from GAP plus 3 CIRAS with 10:30 am, 1:30 pm, and 4:30 pm orbits. .... 226



Figure 99. The final RMSE for the three experiments of EON-MW. GAP assimilates RAOB, AMSU-A from NOAA-15, 18, 19, Aqua, MetOp-A, and B, IASI from MetOp-A and B. CNTL assimilates everything from GAP plus ATMS, and CON-MW assimilates everything from GAP plus EON-MW.....227

Figure 100. CrIS clear field of view statistics for each field of regard. Each field of regard should have about equal clear field of views from each detector. This is true near nadir but deviates at high scan angles.....230

Figure 101. CrIS detector differences for band 2 (midwave). Left panel are errors in degrees Kelvin. Right panel are normalized errors. Detector 7 errors are up to 0.2K or 25% higher than the other detectors.....231

Figure 102. GOES-16 ABI time difference 16 panel CONUS image showing the visible backscatter issue, easily apparent in most as a darker/brighter couplet in VIS/NIR bands. Time difference images are produced at CIMSS in real-time to assist with image quality analysis. ....233

Figure 103. Example 3-panel comparison plot for a single ABI North-South-Scan (ABI CH16, 2017-04-13, 180739 UTC). Similar comparisons have been made for all ABI IR channels and all 3 90-minute Mode 25 ABI cal-val data collects. There are 1206 NSS data files per channel in each 90-minute Mode 25 data collect. Left: brightness temperature map of fields of view being compared (footprints that satisfy the co-location conditions are outlined in black). Top right: Mean S-HIS spectrally resolved brightness temperature (oversampled, blue), mean S-HIS brightness temperature convolved with ABI SRF (grey), mean ABI brightness temperature (red), and ABI normalized SRF (dashed red, plotted vs right hand y-scale). Bottom right: S-HIS spectra used in the mean. ....235

Figure 104. Comparison between colocated GOES-16 ABI and AERI Temperature and relative humidity profiles during the LMOS 2017 field campaign. These comparisons were used to demonstrate that the LAP retrievals pass the product specifications. ....236

Figure 105. This figure shows time/height cross sections of temperature (top) and aerosol backscatter (bottom) for a lake breeze event on 2 June 2017 as measured by SPARC instrumentation. Wind profiles from the SPARC’s Doppler lidar are overlaid on each cross section. Times are in UTC (local time is UTC – 5). Rapid surface cooling in the overnight hours facilitated the development of an inversion, clearly visible as the warm layer overlying the cooler layer in the pre-sunrise hours. Following sunrise, daytime heating contributed to the growth of the PBL (seen in the aerosol backscatter image) and the erosion of the inversion. However, the imbalanced heating of the land relative to the water surface induced a lake breeze which manifests itself in the observations as the turning of the wind vectors, the reduction in aerosol backscatter indicating the advection of cleaner maritime air, and the creation of a new shallow inversion.....237

Figure 106. Measurements of lake ice characteristics over Green Bay during the GLAWEX in February 2017.....239

Figure 107. Ice thickness measurements during the GLAWEX in February 2017.....239

Figure 108. Global Hawk (located at airplane symbol) diverts its flight path to avoid a tropical overshooting top (circle symbol) in high cloud tops during an over-flight of Hurricane Franklin on August 9, 2017. ....241

Figure 109. CLNO3 Regression Testing: Monthly regression coefficients for a 3<sup>rd</sup> order Potential Vorticity (PV) and 1<sup>st</sup> order solar zenith angle have been developed and tested using daily chemical analyses from the 11 year (2006-2016) RAQMS Aura Chemical and Aerosol Reanalysis. The figure shows the Actual (upper left) and Regression (upper right) zonal mean CLNO3 distributions (pptv) and stereo projections of the Actual (lower left) and Regression (lower right) Southern Hemisphere CLNO3 (ppbv) on the 827K isentropic surface, which is at ~10mb. ....243



Figure 110. Comparison between MUSES (upper left), NUCAPS (upper right), RAQMS (lower right) mid-tropospheric carbon-monoxide retrievals on August 05, 2017. The lower left panel shows RAQMS vs NUCAPS for July 30-August 07, 2017 and highlights the cloud artifacts. .... 245

Figure 111. Evaluations from the GOES-S workshop, n=30. .... 247

Figure 112. GOES-16 ABI water vapor band weighting functions for San Juan, Puerto Rico on February 6, 2018 at 00UTC. .... 250

Figure 113. Teachers at Kennedy Space Center just prior to the GOES-S launch. .... 252

Figure 114. GOES-16 movie for NOAA Science On a Sphere (SOS). .... 252

Figure 115. Mat Gunshor of CIMSS presenting at the GOES-R Short Course in Kansas City for the AMS Conference on Broadcast Meteorology. .... 254

Figure 116. First page of Derived Stability Indices Quick Guide. .... 256

Figure 117. This SIFT screen capture shows the graphical user interface (GUI) with annotated capabilities: tools, point probe results, layer list, layer metadata, animation control, background task status, and map display. .... 259

Figure 118. Scott Lindstrom (right) of CIMSS instructing a student during a hands-on exercise at a GOES-R workshop. .... 261



## I. Director's Executive Summary

The Cooperative Institute for Meteorological Satellite Studies (CIMSS) at the University of Wisconsin–Madison (UW–Madison) has been engaged in a strong collaborative partnership with the National Oceanic and Atmospheric Administration (NOAA) since its formation in 1980. We share the goals of monitoring the earth environment more thoroughly through improved remote sensing measurements, maximizing their utilization to realize more accurate and earlier weather prediction, and gaining long term climate perspectives. Through the foundation established by NOAA and the UW-Madison memorandum of understanding, scientists from NOAA/NESDIS and the UW–Madison Space Science and Engineering Center (SSEC) conduct ongoing collaborative research and education. Five scientists from the NOAA/NESDIS Advanced Satellite Product Branch (ASPB) and one scientist from the National Center for Environmental Information (NCEI) are currently stationed at the UW-Madison campus.

This annual report gives detailed updates on the projects supported through the cooperative agreement. Our work is aimed at three mission goals: (1) Foster collaborative research between NOAA and UW–Madison in those aspects of atmospheric and earth science that exploits the use of satellite technology. (2) Serve as a center at which scientists and engineers working on problems of mutual interest may focus on satellite related research in atmospheric studies and earth science. (3) Stimulate the training of scientists and engineers in those disciplines comprising the atmospheric and earth sciences.

Highlights from the past year have been chronicled in the semi-annual magazine “Through the Atmosphere” which can be found at <http://www.ssec.wisc.edu/through-the-atmos/>. The scope of our activities in observations, modelling, atmospheric physics, mentoring, outreach, and operational support is nicely covered in twelve articles from last year.

- (1) New all-hazards ProbSevere model targets tornadoes, hail, wind  
<http://www.ssec.wisc.edu/news/articles/10109>
- (2) Anatomy of a tornado: Using supercomputers to mirror nature's fury  
<http://www.ssec.wisc.edu/news/articles/9772>
- (3) Thunderstorm potential: Predicting cell strength over the Great Plains  
<http://www.ssec.wisc.edu/news/articles/10209>
- (4) Improvements in radiative transfer models  
<http://www.ssec.wisc.edu/news/articles/10327>
- (5) At the crossroads: Turkish student studies Saharan dust from Wisconsin  
<http://www.ssec.wisc.edu/news/articles/10616>
- (6) Lake Michigan Ozone Study  
<http://www.ssec.wisc.edu/news/articles/10053>
- (7) The road to launch: SSEC scientists' efforts to calibrate and validate CrIS and VIIRS on JPSS-1  
<http://www.ssec.wisc.edu/news/articles/10411>





(8) Shared data, shared discovery with JPSS-1  
<http://www.ssec.wisc.edu/news/articles/10538>

(9) Remote sensing seminar comes home to Madison  
<http://www.ssec.wisc.edu/news/articles/10523>

(10) Weather satellite captures 2017 eclipse  
<http://www.ssec.wisc.edu/news/articles/10176>

(11) 2017 AOSS Community Poster Reception  
<http://www.ssec.wisc.edu/news/articles/9915>

(12) AOSS Open House Saturday April 1  
<http://www.ssec.wisc.edu/news/articles/9829>

In the last twelve months, CIMSS assisted in transitioning many GOES-16 algorithms to operations as well as training NWS forecasters and other GOES users in the product applications. CIMSS was also heavily involved in the post-launch checkout of JPSS-1 instruments, especially VIIRS and CrIS. CIMSS continued in their support of NOAA's education and outreach goals with involvement in K-12, undergraduate, graduate and professional training. Further indicating strong collaboration, CIMSS published about one-third of its 2017-2018 peer reviewed papers with NOAA co-authors and one out of six of the 2017-2018 peer reviewed papers included an ASPB or other NOAA scientist as first author (see Appendix 2); these papers included reports on research progress with Suomi NPP and GOES-16 as well as future JPSS observations. NOAA and NASA grants support graduate students in the UW–Madison Department of Atmospheric and Oceanic Sciences (see Appendix 4) who work closely with CIMSS and ASPB scientists.

CIMSS and SSEC also maintain several web sites for external audiences. In addition to the news stories noted earlier (in <http://www.ssec.wisc.edu/news/articles>), they include

- Educational resources for students and teachers:  
<https://cimss.ssec.wisc.edu/education/>
- The CIMSS Satellite Blog for case study discussion and analysis:  
<http://cimss.ssec.wisc.edu/goes/blog/>
- Curated library resources for researchers, students, and teachers:  
<http://library.ssec.wisc.edu/>
- Data and imagery used by external media outlets, researchers, and many others:  
<http://cimss.ssec.wisc.edu/data/> and  
<http://www.ssec.wisc.edu/data/>

In summary, CIMSS is in the third year of the 5-year cooperative agreement with NOAA. The remainder of this report provides a description of the activities undertaken during the period April 1, 2017 through March 31, 2018.



## II. Background Information on the Cooperative Institute for Meteorological Satellite Studies (CIMSS)

### 1. Description of CIMSS, including research themes, vision statement and NOAA research collaborations

The Cooperative Institute for Meteorological Satellite Studies (CIMSS) was formed through a Memorandum of Understanding between the University of Wisconsin–Madison (UW–Madison) and the National Oceanic and Atmospheric Administration (NOAA). The CIMSS formal agreement with NOAA began in 1980 and was continued through a competitive review process in 2010. Following a thorough review of the CIMSS, the Review Panel unanimously agreed to a performance rating of Outstanding. CIMSS completed its 5-year review in December 2013 and a new cooperative agreement funding number was in place in 2015.

The CIMSS mission includes three goals:

- **Foster collaborative research among NOAA, NASA, and the University in those aspects;**
- **Serve as a center at which scientists and engineers working on problems of mutual interest can focus on satellite-related research in atmospheric and earth system science; and**
- **Stimulate the training of scientists and engineers in the disciplines involved in atmospheric and earth sciences.**

To achieve these mission goals CIMSS conducts a broad array of research and education activities, many of which are projects funded through this Cooperative Agreement with NOAA. This Cooperative Agreement identifies four CIMSS themes:

1. **Satellite Meteorology Research**
2. **Satellite Sensors and Techniques**
3. **Environmental Models and Data Assimilation**
4. **Outreach and Education.**

The collaborative relationship between NOAA and the UW–Madison that led to the establishment of CIMSS has provided outstanding benefits to the atmospheric science community and to the nation through improved use of remote sensing measurements for weather forecasting, climate analysis and environmental issues. CIMSS research investigations increase understanding of remote sensing and its numerous applications to weather and nowcasting / forecasting, clouds, aerosols and radiation, the global hydrological cycle, environmental trends, and climate, as well as education and outreach.

CIMSS scientists are engaged in a broad array of research activities and applications as noted in the executive summary and presented in detail in the following sections. CIMSS develops algorithms that are applied to remote sensing measurements to yield information about Earth. This information leads to knowledge about the Earth system that can be utilized in decision-making processes. CIMSS also demonstrates the advantages of improved observations, and works with partners, within and beyond SSEC, in designing and testing advanced instrumentation. At the center of this research process is education - the training of students, professionals and CIMSS itself.

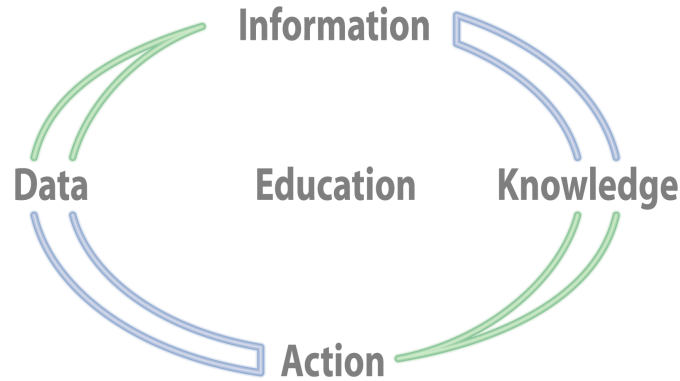

CIMSS conducts a broad array of activities that engages researchers and students in a variety of research and education endeavors.

CIMSS plays a unique role to NOAA as a non-profit partner, advisor, consultant and link to UW-Madison students and researchers. As a long-term partner of NOAA, CIMSS helps to serve as part of the NESDIS corporate memory, particularly when government staff changes positions and roles. For example, original CIMSS/SSEC staff associated with GOES VAS (the first geostationary sounding instrument) and GOES-8/14 design, testing, and checkout are now assisting with similar activities in GOES-16/17/T/U. On the polar orbiting satellite side, our decades long work with the TOVS and ATOVS sounders and the aircraft HIS (High spectral resolution Interferometer Sounder) and scanning-HIS are aiding in the development of applications for the CrIS (Cross-track Infrared Sounder) hyperspectral sounder on Joint Polar Satellite System (JPSS). In addition to bringing “corporate memory” to these new GOES and JPSS programs, the senior staff help to train the next generation of CIMSS scientists who will support future partnerships between CIMSS and NOAA.

CIMSS scientists work side-by-side with the NESDIS/STAR/ASPB (Advanced Satellite Products Branch) scientists who are stationed in Madison. The advantages of collocation in the same building and similar research interests generate productive collaborations. In addition, ASPB scientists often mentor graduate students on research projects that address NOAA needs while helping to satisfy UW–Madison degree requirements. Based on this positive experience, many of these students go on to work with NOAA and supporting contractors.

Within the NOAA National Weather Service (NWS), CIMSS collaborates on data assimilation projects with the National Centers for Environmental Prediction (NCEP). The CIMSS tropical cyclone research team maintains close collaboration on new products development with the Tropical Prediction Center (NCEP/TPC) in Miami. CIMSS works with the Storm Prediction Center (NCEP/SPC) in Norman, OK on satellite applications to severe weather analysis and forecasting. CIMSS collaborates with the Aviation Weather Center (NCEP/AWC) in Kansas City on aviation safety projects that utilize weather satellite data.

## 2. CIMSS Management and Administration

CIMSS resides as an integral part of the University of Wisconsin-Madison Space Science and Engineering Center (SSEC). The CIMSS Principal Investigator on most programs is Steve Ackerman. Executive Director – Science Wayne Feltz provides day-to-day oversight of the CIMSS staff, science programs, and facilities. The individual science projects are led by University Principal Investigators (PIs) in conjunction with a strong and diverse support staff who provide additional expertise to the research programs. CIMSS is advised by a Board of Directors and a Science Advisory Council (Section II. 4 below).



The CIMSS administrative home is within the Space Science and Engineering Center (SSEC), a research and development center within the UW–Madison’s Office of the Vice Chancellor for Research and Graduate Education (OVCGE). The independent CIMSS 5-year review panel for administration wrote that they were “...impressed by the people, systems and processes in place.” The SSEC mission focuses on geophysical research and technology to enhance understanding of the Earth, other planets in the Solar System, and the cosmos. To conduct its science mission on the UW–Madison campus, SSEC has developed a strong administrative and programmatic infrastructure. This infrastructure serves all SSEC/CIMSS staff.

SSEC support infrastructure includes:

- **Administrative support**  
The administrative support team includes approximately 14 full-time staff and several students providing services that include human relations, proposal processing and publishing, grant and contract management, accounting, financial programming, purchasing and travel.
- **Technical Computing**  
The technical computing support team includes 6 full-time staff and several students providing consultation and implementation on system design, networking infrastructure, and full support for Unix and pc computing.
- **Data Center**  
The SSEC Data Center provides access, maintenance, and distribution of real-time and archive weather and weather satellite data. The Data Center currently receives data from 8 geostationary and 7 polar orbiting weather satellites in real time and provides a critical resource to SSEC/CIMSS researchers.
- **Library and Media**  
SSEC maintains an atmospheric science library as part of the UW–Madison library system. A full time librarian is on staff and two part time assistants. SSEC also employs a full time media specialist to support the dissemination of information on scientist activities and research results and to develop in-house publications.
- **Visualization Tools**  
SSEC is a leader in developing visualization tools for analyzing geophysical data. The Man-computer Interactive Data Access System (McIDAS and McIDAS-V), Vis5D and VisAD software are used worldwide in a variety of research and operational environments. The VISITView software is used extensively as a tele-training tool by the NWS and others. To further support NOAA NWS forecast offices, CIMSS is developing satellite products for AWIPS and AWIPS2, maintaining both systems within our facilities.

### 3. Summary of NOAA Funding to CIMSS in FY2017

In FY2017, funding to CIMSS through Cooperative Agreement Federal Funding Opportunity NOAA-NESDIS-NESDISPO-2017-2005096 totaled \$10,345,219 (includes Task 1 and Task 2 funding). FY2018 funding is not sufficiently known at this time to include in this report but will most likely be substantially more than CIMSS CA FY2017 budget total due to increases in research to operations budgets for GOES-16/17 and JPSS. The following tables and graphics show the distribution of these funds by Task, by NOAA Strategic Goal and by CIMSS Research and Outreach Theme. The total represents FY2017 funds provided to CIMSS under the Cooperative Agreement that began on 1 July 2017 and covers the 9 month period from 1 July 2016 to 31 March 2018.



### FY2017 Funding by NOAA Task

CIMSS Task	Funding in dollars	Percentage
Task 1: Administration	\$ 369,022	4%
Task 2: Research primarily with NESDIS Scientists	\$ 9,976,197	96%
Task 3: Research with other NOAA Programs	\$ 0	0%
	\$10,345,219	100%

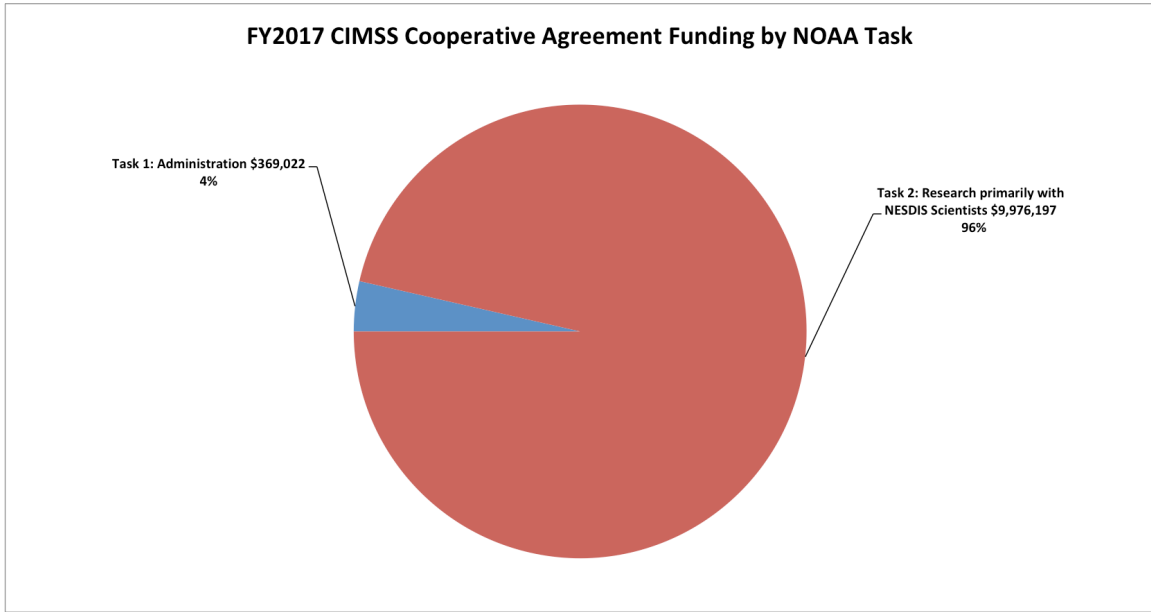

Nearly 96% of CIMSS funding is for Task 2 (~69 employees FTE funded at 50% or greater) and is research conducted with ASPB scientists.



Research primarily falls under NOAA’s Strategic Goal Weather Ready Nation.

**Funding by NOAA Strategic Goal**

<b>NOAA Strategic Goal</b>	<b>Funding in dollars</b>	<b>Percentage</b>
Weather-Ready Nation	\$9,050,719	92%
Climate Adaption and Mitigation	\$1,294,500	13%
Healthy Oceans	\$0	0%
Resilient Coastal Communities and Economies	\$0	0%
	\$10,345,219	

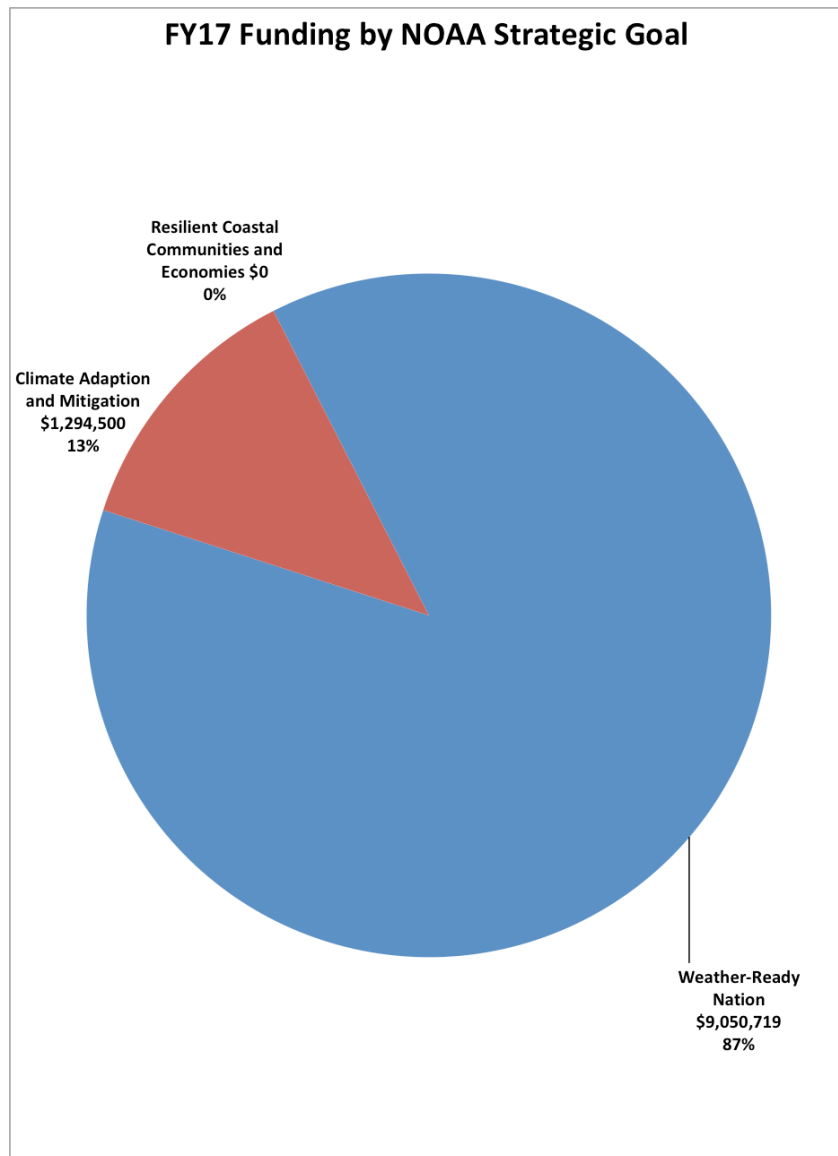



### Task 2 Funding by CIMSS Research and Outreach Themes

CIMSS Theme	Funding in dollars	Percentage
Satellite Meteorology Research and Applications	\$5,789,241	56%
Satellite Sensors and Techniques	\$3,449,771	33%
Environmental Models and Data Assimilation	\$153,349	1%
Education and Outreach	\$1,331,652	10%
	\$10,345,219*	100%

\* - does not include the Task 1 funding

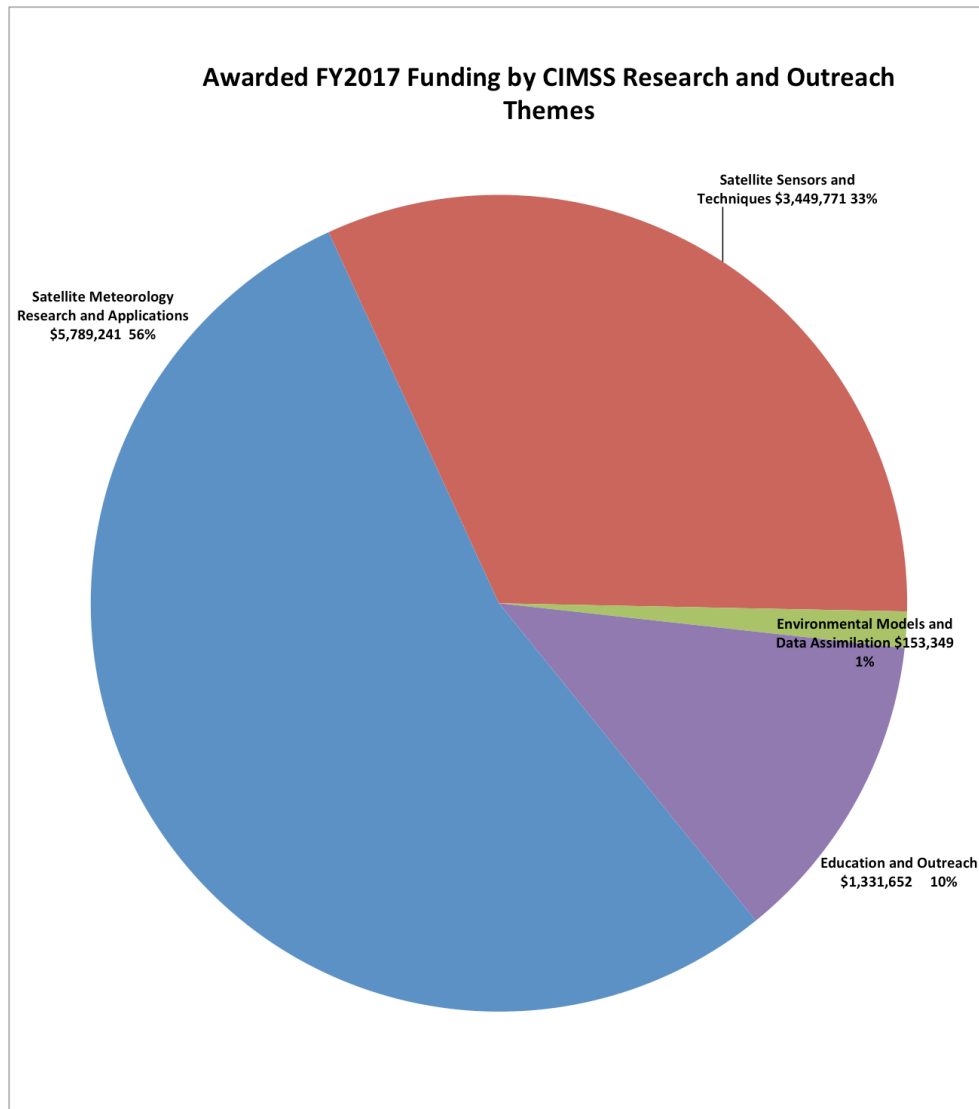



### III. Project Reports

The sections below provide two-three page summaries for each of the various projects funded by NOAA through the CIMSS cooperative agreement. Each summary lists the project leader, the NOAA goals and the CIMSS themes followed by a summary of the project accomplishments this past year. Where appropriate, relevant publications and conference presentations are listed.

#### 1. CIMSS Task 1A Support

**CIMSS Task Leaders: Steve Ackerman, Wayne Feltz**

**CIMSS Support: Paul Menzel, Maria Vasys, Leanne Avila, Wenhua Wu, Jenny Hackel, Margaret Mooney**

##### **NOAA Long Term Goals:**

- Climate Adaptation and Mitigation
- Weather-Ready Nation

##### **NOAA Strategic Goals:**

- Provide critical support for the NOAA mission

##### **CIMSS Research Themes:**

- Satellite Meteorology Research and Applications
- Satellite Sensors and Techniques
- Environmental Models and Data Assimilation
- Education and Outreach

##### **Objective**

The CIMSS Task I funds continue to support the administrative needs for the CIMSS Director, the CIMSS Executive Director - Science and the CIMSS Staff Program Assistant Maria Vasys provides that support and is also supported by student hourly employees to maintain a consistent presence in the CIMSS administrative office.

##### **Project Overview**

The CIMSS Task 1 funding supports activities related to CIMSS administration and non-research programs that are important to the workplace environment of CIMSS. Partial administrative support is provided for the CIMSS Director, Executive Director - Science, the Program Assistant, and the CIMSS Webmaster. Task I activities also includes leveraging support for education and outreach projects, per diem support for visiting scientists, post doctoral positions and first year graduate students.

##### **Milestones with Summary of Accomplishments and Findings**

Task I activities are related to the overall management of CIMSS, as well as general education and outreach activities. These are activities which support the operation of CIMSS; provide outreach platforms to transmit CIMSS science to varied audiences; train and develop future scientists in the workforce; and provide capabilities requested under the Federal Funding Opportunity NOAA-NESDIS-NESDISPO-2017-2005096, but which are not tied to a specific project or projects. Task I funding includes partial funding/salary support for the CIMSS PI/Director, and other support staff, travel, and visiting researcher support. Also, inclusive of Task I are educational and outreach activities including support of post-docs and graduate students within CIMSS not assigned to specific projects or research; support of undergraduate





research interns; development of community outreach, education, and training programs; and support for CIMSS education and outreach staff.

Task I funding supports the development and updates of the CIMSS Web page (see <http://cimss.ssec.wisc.edu/>). The CIMSS Web page is closely linked to the NOAA ASPB Web site (<http://cimss.ssec.wisc.edu/aspb/>) and to the SSEC Web site (<http://www.ssec.wisc.edu>).

CIMSS has created the “NOAA-CIMSS Collaborative Award for developing NOAA’s Strategic Satellite Plan to balance requirements, observation capabilities, and resources.” These awards may be given to CIMSS scientists who have worked closely with NOAA scientists who have received a NOAA award. The CIMSS award is to recognize the partnership that occurs in research with ASPB and UW-Madison scientists.

## **2. CIMSS Task 1B Support – Education and Public Outreach**

**CIMSS Task Leaders: Margaret Mooney and Steve Ackerman**

**CIMSS Support Scientists: Scott Bachmeier and Rick Kohrs**

**NOAA Collaborators: Tim Schmit, Steve Goodman, & LuAnn Dahlman**

**Budget: \$69,000**

### **NOAA Long Term Goals:**

- Climate Adaptation and Mitigation
- Weather-Ready Nation
- Resilient Coastal Communities and Economies

### **NOAA Strategic Goals:**

- Serve society’s needs for weather and water
- Understand climate variability and change to enhance society’s ability to plan and respond
- Provide critical support for the NOAA mission

### **CIMSS Research Themes:**

- Satellite Meteorology Research and Applications
- Education and Outreach

### **Objective**

Raise awareness and appreciation of satellite remote sensing resources to advance weather and climate literacy across society.

### **Project Overview**

CIMSS Education and Public Outreach (EPO) prioritizes awareness around satellite remote sensing and advancing weather and climate literacy across society. CIMSS EPO initiatives include a variety of formal and informal education projects, ranging from classes and workshops at the University of Wisconsin-Madison to presentations at conferences, museums and schools. CIMSS has been on the forefront of educational software design for over three decades and currently supports several on-line curriculums, educational tools, social media sites and blogs.

### **Milestones with Summary of Accomplishments and Findings**

CIMSS EPO efforts include local and national initiatives. During the 12-month reporting period that began in April 2017, an obvious priority for all CIMSS EPO efforts was promoting our



nation's newest geostationary and polar-orbiting satellites, GOES-16, GOES-17 and NOAA-20. This includes showcasing these satellites locally on the UW-Madison campus to students on field trips, or with participants in our annual high school student workshop or and alumni attending the Grandparents University meteorology major. This was equally true for national events such as ESIP Teacher Workshops and the American Meteorological Society (AMS) annual conference, as well as international events like the EUMETSAT conference. Stunning new imagery and capabilities from our new satellites epitomize the definition of a 'teachable moment' and provide perfect avenues for furthering STEM (science, technology, engineering and math) education.

The annual CIMSS Student Workshop on Atmospheric, Satellite, and Earth Sciences took place in June 2017, and featured an exciting five-day STEM agenda in meteorology, astronomy, remote sensing and geology. Twelve (12) high school students from Wisconsin, Minnesota and Illinois, 8 girls and 4 boys, experienced hand-on science and research while gaining exposure to career options. Five (5) students visiting from Korea also participated in several of the workshop sessions.



**Figure 1. CIMSS student group visiting NWSFO MKX.**

In July 2017 CIMSS organized the meteorology major for Grandparents University where University of Wisconsin-Madison (UW) alumni attend 2-days of activities with their grandchildren. Also in July, CIMSS co-organized at a teacher workshop at the summer meeting of the Earth Science Information Partners (ESIP) and presented GOES-16 resources. CIMSS has helped organize ESIP teacher workshops since 2009, initiating NOAA support for complimentary teacher registrations.

In August 2017 CIMSS organized a teacher workshop hosted by Lockheed Martin. Forty educators registered and thirty attended the exciting 1-day event. For those that made it, a unique



experience ensued. The full agenda with links to power-point presentations are on-line at <http://www.cimss.ssec.wisc.edu/education/goesr/GOES-S.html>.

Workshop evaluations collected at the end of the day resulted in seventeen participants giving the workshop an overall rating of “excellent”, ten chose “very good” and three chose “good”. Comments collected indicated that some teachers found the science content challenging but everyone especially appreciated the opportunity to view the fully assembled GOES-S satellite. Because of the workshop, participants received official invites to the 2018 GOES-S launch, and over a dozen attended!



**Figure 2. GOES-S Teachers at Lockheed Martin, posing in front of the GOES-S satellite.**

CIMSS has also been producing content for NOAA’s Science On a Sphere® (SOS) and in 2017 published four quarterly climate digests and a feature story entitled “GOES-16 tracks the Big 3”. (<http://sphere.ssec.wisc.edu/>) The GOES-16 video was featured at Kennedy Space Center for the GOES-S launch!

In the digital domain, CIMSS maintains educational content via on-line curriculum for students and teachers linked from the CIMSS education webpage (<https://cimss.ssec.wisc.edu/education/>). CIMSS also maintains two twitter accounts and a Facebook page. @UWCIMSS, in its fourth year, conveys a broad range of content to 7,300 followers. The CIMSS Facebook page (<https://www.facebook.com/CIMSS.UW.Madison>) has just over 11,000 fans.

CIMSS social media is the primary vehicle for sharing NOAA-20 successes with the public, including an informal project to match VIIRS Day/Night Band images of the Aurora Borealis with ground based citizen science pictures. In spite of obvious temporal and spatial challenges, simply combining satellite images with pictures from the same night elicits positive social media



comments like “This is by far the coolest tweet! I’ve always wanted to see concurrent views, from land and space.”



Figure 3. September 2017 tweet via @UWCIMSS.

Finally, the CIMSS Satellite Blog (<http://cimss.ssec.wisc.edu/goes/blog/>) has been showcasing examples of meteorological satellite images and products for over a decade and is often referenced in major newspaper publications. The associated twitter account (@CIMSS\_Satellite) has 39,300 followers.

### Publications and Conference Reports

Knox, John A.; Ackerman, S. and Whittaker, T. A textbook case of going virtual. Symposium on Education, 27th, Houston, TX, 7-11 January 2018. American Meteorological Society, Boston, MA, 2018, Abstract 1.3.

Mooney, Margaret. Galvanizing educator awareness around the GOES-R satellite series with Science Teachers, Science Centers and TV Broadcasters. EUMETSAT New Generation Operational Environmental Satellites. Rome, Italy, 2-6 October 2017.

Mooney, Margaret; Whittaker, T. M.; Ackerman, S. and Schmit, T. J. HTML5 WebApps from the Cooperative Institute for Meteorological Satellite Studies. Symposium on Education, 27th, Houston, TX, 7-11 January 2018. American Meteorological Society, Boston, MA, 2018.

Mooney, Margaret. Galvanizing educator awareness around the GOES-R satellite series. Annual Symposium on New Generation Operational Environmental Satellite Systems, 14th, Houston, TX, 7-11 January 2018. American Meteorological Society, Boston, MA, 2018.



### **3. CIMSS Participation in the Product Systems Development and Implementation (PSDI) for 2017**

#### **3.1 JPSS PSDI: VIIRS Polar Winds**

**CIMSS Task Leader: David Santek**

**CIMSS Support Scientists: Steve Wanzong, Rich Dworak**

**NOAA Collaborators: Jeff Key, Jaime Daniels**

**Budget: \$50,000**

#### **NOAA Long Term Goals:**

- Weather-Ready Nation

#### **NOAA Strategic Goals:**

- Serve society's needs for weather and water
- Provide critical support for the NOAA mission

#### **CIMSS Research Themes:**

- Satellite Meteorology Research and Applications
- Satellite Sensors and Techniques

#### **Objective**

The objective of the project is to evaluate the suitability of the VIIRS winds algorithm for the JPSS-1 satellite system and make modifications as necessary. We will provide support to evaluate and validate the cloud and wind products updates, participate in the Critical Design Review (CDR), and assist with documentation.

#### **Project Overview**

The VIIRS polar winds product is currently operational for the Suomi National Polar-orbiting Partnership (S-NPP) satellite and provides wind speed, direction, and pressure of cloud-tracked features at high latitudes. These winds have been produced operationally by NESDIS since May 2014 and are also being distributed via the European Organisation for the Exploitation of Meteorological Satellites (EUMETSAT) EUMETCast broadcast. The VIIRS winds are being assimilated in the Naval Research Lab's (NRL) Atmospheric Variational Data Assimilation System - Accelerated Representer (NAVDAS-AR) and are currently being monitored in NCEP's pre-operational version of the Global Data Assimilation System/Global Forecast System GDAS/GFS. They are also used by some numerical weather prediction centers abroad.

With the launch of JPSS-1 (now NOAA-20) in November 2017, a modification to the winds algorithm will be needed to incorporate updates to the VIIRS cloud mask and height algorithms. The CIMSS polar winds team will participate by providing support to evaluate the cloud and wind products updates, participate in the Critical Design Review (CDR) and other reviews, and assist with documentation. Also, CIMSS will investigate the use of other VIIRS channels (e.g., shortwave infrared and the Day/Night Band (DNB)) to produce polar winds and the possibility of using a mix of S-NPP and JPSS-1 passes to produce winds, if the orbits are offset by  $\frac{1}{2}$  orbit in time (similar to Metop-A and -B). This will improve the product due to the shorter time interval when tracking features between images and expanding the coverage into the upper mid-latitudes.

#### **Milestones with Summary of Accomplishments and Findings**

The VIIRS Polar Winds product became operational in NESDIS in May 2014. It is the first polar winds product to use the algorithm that was developed for GOES-R, and the first NESDIS



product to become operational using a GOES-R algorithm. Currently, only the 11  $\mu\text{m}$  channel is processed. However, we have been investigating the use of additional spectral channels for tracking cloud features, specifically in the shortwave infrared (SWIR) band. Initial results from the MODIS 2.1  $\mu\text{m}$  channel are encouraging, resulting in additional winds being retrieved. In addition, a preliminary evaluation by Randy Pauley (Fleet Numerical Meteorology and Oceanography Center) indicates the SWIR winds are of similar quality as the MODIS IR winds when assimilated into the Navy Global Environmental Model (NAVGEM) (personal communication). We will further evaluate the MODIS SWIR winds and extend the winds algorithm to a similar channel on VIIRS, such as the M11 (2.25  $\mu\text{m}$ ).

During the past year the majority of the effort has been focused on implementing the winds cluster algorithm at CIMSS. Due to the complexity of the Algorithm Integration Team (AIT) Framework processing system running in NESDIS operations, of which the winds is just one component, we use a more stand-alone application: The GEOstationary Cloud Algorithm Test-bed (GEOCAT)-based implementation of the cluster algorithm. This GEOCAT version has not run in a routine processing mode, therefore, several software modifications were required:

- Updates to the Makefile to better handle external libraries and newer compilers when building GEOCAT and the winds algorithm;
- The addition of an environment variable to enumerate input file names;
- The algorithm would *segmentation fault* when missing data values were encountered. A software change was made to guard against values outside of a nominal range;
- Software modifications were required for the algorithm to generate the winds product in the Southern Hemisphere;
- For MODIS winds processing, only MODIS from Aqua was enabled. A software modification was made for Terra processing; and
- Processing scripts were written to routinely generate winds from both Terra and Aqua MODIS.

We have now begun validating the MODIS polar winds derived using both the heritage algorithm and the cluster algorithm. Initial results indicate better statistics (reduced RMSE) for the cluster algorithm as compared to rawinsondes. The next step is to begin routine winds processing of the VIIRS data.

Also, we continue to maintain and pursue new opportunities to generate the VIIRS polar winds at Direct Broadcast (DB) sites in high latitude locations, such as Fairbanks, Alaska, Sodankylä, Finland, and Antarctica. This results in a product with reduced latency, available approximately 2-3 hours sooner. However, the software that is currently running at DB sites is the heritage winds software, instead of the cluster algorithm which is used in NESDIS operations. The software at the DB locations will be updated to the CIMSS-implemented cluster algorithm within GEOCAT, as part of an update to the codebase for the MODIS and AVHRR polar winds products.

### **3.2 GEO PSDI: Enterprise Processing Ground System – Fog and Low Cloud Products**

**CIMSS Task Leader: Corey Calvert**

**CIMSS Support Scientist: William Straka**

**NOAA Collaborator: Michael Pavolonis**

**Budget: \$65,000**



### **NOAA Long Term Goals:**

- Weather-Ready Nation

### **NOAA Strategic Goals:**

- Serve society's needs for weather and water
- Support the nation's commerce with information for safe, efficient and environmentally sound transportation
- Provide critical support for the NOAA mission

### **CIMSS Research Themes:**

- Satellite Meteorology Research and Applications
- Satellite Sensors and Techniques

### **Objective**

We seek to transition the GOES-R Fog/Low stratus (FLS) products to NOAA/NESDIS operations within the AIT framework.

### **Project Overview**

The goal of this project is to address the Satellite Products and Services Review Board (SPSRB) user request 1305-004, submitted by the NWS, to transition the GOES-R Fog/Low stratus (FLS) products to NOAA/NESDIS operations within the STAR Algorithm Processing Framework (SAPF). We therefore propose to work with the STAR AIT to transition the GOES-R FLS algorithm by developing a product interface that can be used within the SAPF. Once the interface is completed we will continue working with the STAR AIT to evaluate and validate the FLS product output from the SAPF to ensure the quality of the products.

### **Milestones with Summary of Accomplishments and Findings**

- *Implementation of the GOES-R FLS algorithm in AIT Framework*  
The initial implementation of the GOES-NOP version of the GOES-R FLS algorithm into the SAPF was successful. With the launch of GOES-R and GOES-S, further algorithm updates and corresponding look-up tables specific to the GOES-R version of the FLS algorithm are necessary. These updates have been delivered and implemented into the SAPF; however, the products have not yet been thoroughly evaluated. An example of the GOES-R IFR probability product applied to a GOES-16 full-disk scene from the SAPF is shown in Figure 4.
- *Evaluate modifications to the SAPF required to create FLS products*  
Several modifications to the SAPF were needed to ensure the FLS products are produced with the quality and accuracy expected by the developers. The modifications included adding the ability to use the OISST as a surface temperature ancillary data set, incorporation of multiple NWP models and domains (e.g., global GFS and multiple RAP mesoscale domains) and the ability to re-map the satellite data to a constant grid which is necessary to access temporal data. All modifications were closely evaluated and the correct implementation was confirmed.
- *Validate GOES-NOP version FLS output from the AIT framework*  
Output from 12 days (one day from each month of 2016) was used to validate the GOES-NOP version of the GOES-R FLS products from the SAPF. The LIFR/IFR/MVFR probabilities were validated using co-located surface observations of cloud ceiling and surface visibility. The cloud thickness product was previously validated using Sonic Detection And Ranging (SODAR) data.



For the LIFR/IFR/MVFR probability products, the required specification is 70% accuracy. The validation was performed for each flight rule category for day (solar zenith angle  $< 80^\circ$ ), terminator (solar zenith angle between  $80^\circ$ - $90^\circ$ ) and night (solar zenith angle  $> 90^\circ$ ) pixels separately using probability thresholds that yielded the maximum skill, determined by the Critical Success Index (CSI), for each dataset. The accuracy of the GOES-R LIFR/IFR/MVFR probability products for all solar orientations were all found to be  $> 80\%$ , thus comfortably meeting the 70% accuracy requirement.

Attributes diagrams were also produced to further demonstrate the skill of the probability products. Examples of these diagrams for the IFR probability product (Figure 5) show that the FLS probabilities appear to be well calibrated.

The required specification for the cloud thickness product is to be accurate within 500m for single layer liquid clouds. Using SODAR data as our validation source we determined the GOES-R cloud thickness product produced biases of  $< 50\text{m}$  for both day and night, indicating that the 500m accuracy will be readily achieved.

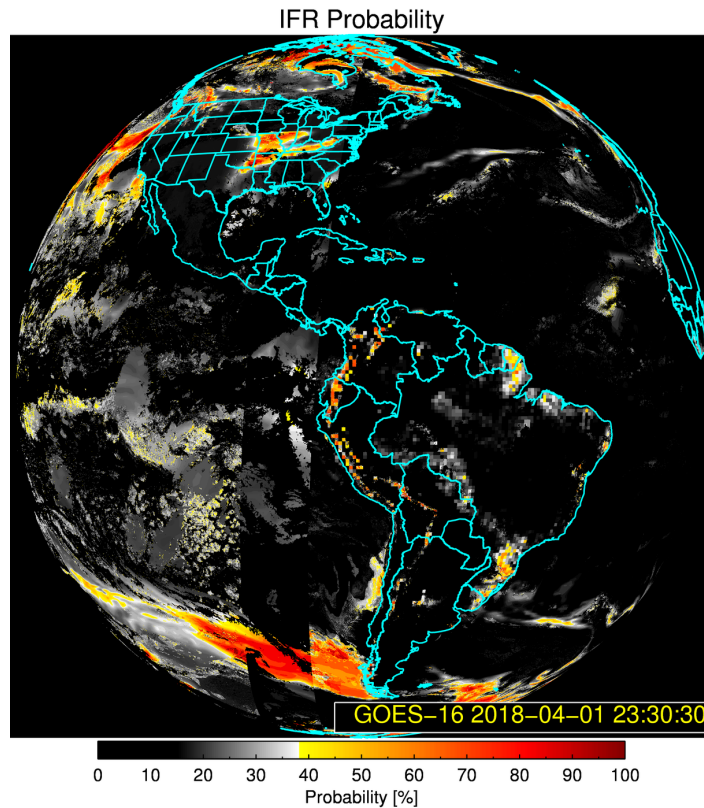

**Figure 4.** The GOES-R IFR probability product applied to a GOES-16 full-disk scene from April 1, 2018 at 23:23 UTC produced by the SAPF.



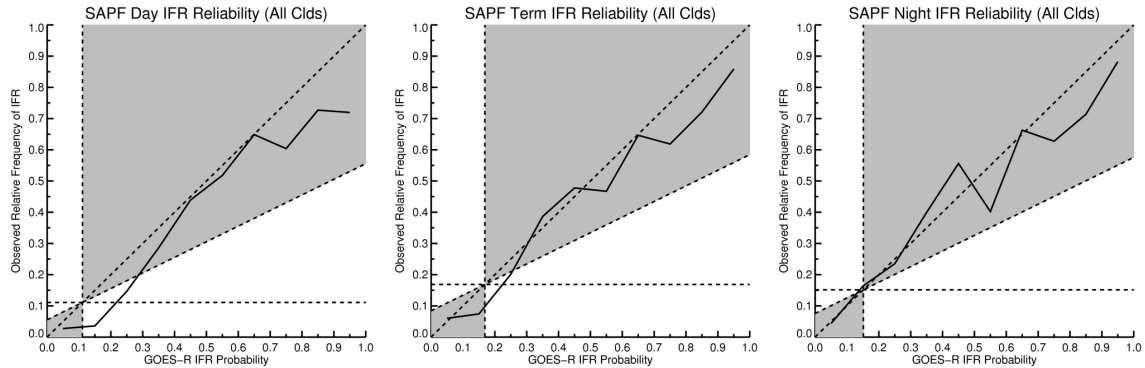

**Figure 5.** The attributes diagrams for the GOES-NOP version of the GOES-R IFR probability product, applied to GOES-13, produced from the NOAA/NESDIS operational STAR Algorithm Processing Framework (SAPF) for daytime (solar zenith angle  $< 80^\circ$ ), terminator (solar zenith angle between  $80^\circ$ - $90^\circ$ ) and nighttime (solar zenith angle  $> 90^\circ$ ) pixels. These diagrams include pixels composed of both water and ice. Points that lie within the shaded region indicate that the model has skill over climatology. This analysis shows that the GOES-R IFR probabilities being transitioned to NOAA/NESDIS operations are generally well calibrated. Over 1,000,000 surface observations from all 12 months of 2016 were used in this analysis.

### 3.3 Blended Advanced Dvorak Technique (ADT) Upgrades

**CIMSS Task Leaders: Chris Velden and Tim Olander**

**NOAA Collaborator: Jeff Key**

**Budget: \$70,000**

#### NOAA Long Term Goals:

- Weather-Ready Nation

#### NOAA Strategic Goals:

- Serve society's needs for weather and water
- Provide critical support for the NOAA mission

#### CIMSS Research Themes:

- Satellite Meteorology Research and Applications
- Satellite Sensors and Techniques

#### Objective

This project addresses the operational transition component of the ADT, and will help carry the recent and expected improvements into the operational version now supported by NESDIS.

#### Project Overview

The Advanced Dvorak Technique (ADT) is an algorithm designed to provide objective estimates of hurricane intensity from GOES and other geostationary satellites. Its long-term development has been partially supported by GIMPAP, and the upgraded algorithm versions have been transitioned through previous PSDI efforts into NESDIS operations at the Satellite Analysis Branch. The National Hurricane Center (NHC) now routinely accesses the ADT data as part of its hurricane analysis suite of tools.

In support of the importance of the ADT in hurricane analysis at the U.S. operational centers, a joint User Request was submitted to the SPSRB by NHC, CPHC (Central Pacific Hurricane Center), and JTWC (Joint Typhoon Warning Center). The request, Request No: 1412-0015, Title: "Continue operational transition and upgrade support of the ADT," was approved by the SPSRB



for funding considerations starting in FY16. The work performed in this PSDI project addresses the operational transition component, which will help carry the recent and expected improvements into the operational version now supported by NESDIS.

### **Milestones with Summary of Accomplishments and Findings**

Efforts this year have focused on readying the latest experimental ADT version code that will transition into the operational framework at OSPO. Specifically, new science/upgrades have been implemented, as well as testing of inputs from new satellites such as Himawari-8, GOES-16, F-19, GCOM and GPM. Experimental real-time testing and validation is being conducted at CIMSS. An updated code package (ADT V9.0) is being delivered this spring.

### **3.4 JPSS Cal/Val Support – Volcanic Ash EDR**

**CIMSS Task Leader: Justin Sieglaff**

**CIMSS Support Scientist: Corey Calvert**

**NOAA Collaborator: Michael Pavolonis**

**Budget: \$50,000**

#### **NOAA Long Term Goals:**

- Weather-Ready Nation

#### **NOAA Strategic Goals:**

- Serve society's needs for weather and water
- Support the nation's commerce with information for safe, efficient and environmentally sound transportation
- Provide critical support for the NOAA mission

#### **CIMSS Research Themes:**

- Satellite Meteorology Research and Applications
- Satellite Sensors and Techniques

#### **Objective**

The assembled team will validate, maintain, and improve the JPSS Volcanic Ash EDR.

#### **Project Overview**

Volcanic ash is a major aviation hazard. Satellites are the primary tools used to identify, track, and characterize volcanic ash clouds. The VIIRS sensor on the S-NPP and JPSS satellites is key for identifying volcanic ash emissions. As such, a requirement for a JPSS volcanic ash Environmental Data Record (EDR), at the VIIRS spatial resolution, was established for the NDE system. The algorithm used to produce the JPSS Volcanic Ash EDR in NDE is similar to the algorithm utilized within the GOES-R Ground System. Currently, only VIIRS data are utilized to generate the Volcanic Ash EDR, which consists of ash loading, height, and effective radius products. The goals of this project are to validate, maintain, and improve the JPSS Volcanic Ash EDR. Validation is primarily accomplished through regular comparisons with space borne lidar measurements, either by direct or vicarious means. Maintenance is achieved through the provision of optimized thresholds and look-up tables for each JPSS satellite, and by ensuring that the thresholds and LUTS remain optimal over time. This project also seeks to improve the JPSS Volcanic Ash EDR through incorporation of CrIS measurements.



### **Milestones with Summary of Accomplishments and Findings**

- The JPSS Volcanic Ash EDR Cal/Val plan was drafted and finalized during 2017. The Cal/Val plan outlines the data sources (both passive IR and active lidar), code, and statistical metrics used to validate the JPSS Volcanic Ash EDR. The activities outlined in the Cal/Val plan will be performed during FY 18 and 19.
- A new Look-Up Table (LUT) with necessary coefficients for JPSS Volcanic Ash EDR retrieval was created to support NOAA-20.

### **Publications and Conference Reports**

Pavlonis, M. J., A. K. Heidinger, and J. Sieglaff (2013), Automated retrievals of volcanic ash and dust cloud properties from upwelling infrared measurements, *J. Geophys. Res. Atmos.*, 118, doi:[10.1002/jgrd.50173](https://doi.org/10.1002/jgrd.50173).

### **References**

Pavlonis, M. J., 2010: Advances in extracting cloud composition information from spaceborne infrared radiances: A robust alternative to brightness temperatures. Part I: Theory. *J. Applied Meteorology and Climatology*, 49, 1992-2012.

## **4. CIMSS Participation in the GOES-R Algorithm Working Group (AWG) in 2017-2018**

### **4.1 Algorithm Integration Team Technical Support**

**CIMSS Task Leader: R. Garcia**

**CIMSS Support Scientists: G. Martin, E. Schiffer, W. Straka, A. De Smet**

**NOAA Collaborators: M. Pavlonis, W. Wolf**

**Budget: \$289,000**

#### **NOAA Long Term Goals:**

- Weather-Ready Nation

#### **NOAA Strategic Goals:**

- Provide critical support for the NOAA mission

#### **CIMSS Research Themes:**

- Satellite Meteorology Research and Applications
- Satellite Sensors and Techniques

### **Objective**

Provide integration and technical support for the GOES-R Algorithm Working Group teams at CIMSS

### **Project Overview**

The AIT-Midwest handles aspects of computer science cross-cutting AWG algorithm development teams at CIMSS/SSEC, and works in cooperation with the ASSISST team in Washington, DC. This includes software development practices, software process management, documentation, testing and automation, infrastructure, general computing assistance, and systems design and optimization.



#### Principal Activities:

- Review and update software and deliverables with CIMSS science staff, for integration by NESDIS STAR ASSISST, in support of updates to GOES-R development environment (DE).
- Maintain, extend, and deploy verification and automation test tools in coordination with ASSISST.
- Provide guidance to science staff to improve computer science aspects of algorithm reference software, including authoring tools, example implementations and libraries.
- Provide test data, software, storage and computing resources as needed for GOES-R series verification, validation, integration and research uses within CIMSS/SSEC.
- Feedback and technical interchange with ASSISST and Harris/AER regarding computer science concerns and verification of algorithm implementations and operational framework interfaces.
- Profile reference algorithm implementations and explore performance, accuracy, and reproducibility improvements.

#### Milestones with Summary of Accomplishments and Findings

- Continued work on verification testing of updated CIMSS reference algorithms in SAPF (STAR Algorithm Processing Framework) for use at NOAA.
- Verified algorithm fixes for Baseline Algorithms
  - Primarily this dealt with updates to the Cloud Mask algorithm, but also included other algorithms including Fires and DCOMP
- Improvements to Glance verification toolset, responding to AWG and ASSISST team requests and objectives. Released Glance 0.3.3 to AWG and ASSISST teams, specifically improving support for operational ABI data formats and providing ready-to-install software packages.
- Supported Harris test product verification, providing necessary feedback. This included support the GOES-R Ground Segment Project with the verification of the Level-2 product output generated by the GOES-R Ground Segment Contractor (Harris), as well as familiarization and review of Level-2 product software developed by the GOES-R Ground Segment Contractor (Harris / AER).
- Performed assessment of Harris/AER operational code algorithm samples.
- SAPF workflow and automation improvements to improve speed of algorithm integration and testing work. Several software patches contributed to help improve SAPF.
- Streamlined source code synchronization with ASSISST through Gitlab software source management tools.
- Continued development on ‘libHimawari’ C/Fortran/Python callable toolbox used for algorithm development systems to access Himawari Standard Data and HimawariCast formats, permitting imagery and Level 2 algorithms to be tested shortly after the availability of AHI near-real-time data.
- Tool and library development to assist in visualizing, navigating, verifying, and manipulating ABI and AHI data in Product Users Guide (PUG) conformant files.
- Technical and product feedback for AHI provided to JMA through NOAA channels.
- Technical and product feedback to GOES-R PRO team regarding ABI and associated products.
- Acquired and distributed test and ancillary datasets in support of AWG deliverables, validation, and verification.
- Continued involvement in SAPF reference framework development and maintenance



- This includes CIMSS configuration management, build and execution automation for the SAPF. This will provide routine local processing of the SAPF specifically for CIMSS AWG uses.
- Integration activities for CIMSS algorithm updates for delivery to ASSISST.
- Management and coordination of schedules, deliveries, software configuration items in cooperation with AWG and Harris/AER.
- Participated in ongoing training for ground segment Algorithm Test Tools (ATT).
- Supported the storage and distribution of GOES-16 PDA and GRB for GOES-16 datasets as well as Himawari-8 HSD/HimawariCast datasets for verification, validation, integration and research uses within CIMSS/SSEC. This includes acquisition of further storage-area-network (SAN) resources at CIMSS/SSEC to buffer multiple weeks of ABI and AHI for cluster and workstation use by researchers.
- Worked with scientists and SSEC Data Center staff to establish an AMQP-based messaging architecture. This allows research and near-realtime processing to launch immediately upon availability of ABI data on the research SAN and other distribution points. Additional functionality implemented during 2017 includes easy specification of automatic fail-over between message queues as well as data sources.
- Participated, in beta and provisional presentations for various algorithms, providing guidance as needed. In addition, verified any issues that the teams found during their analysis

## **4.2 ABI Cloud Products**

**CIMSS Task Leader: William Straka III**

**CIMSS Support Scientists: Denis Botambekov , Corey Calvert , Pat Heck , Jay Hoffman, Yue Li, Andi Walther, Steve Wanzong**

**NOAA Collaborators: Andrew Heidinger, Michael Pavolonis**

**Budget: \$439,000**

### **NOAA Long Term Goals:**

- Weather-Ready Nation

### **NOAA Strategic Goals:**

- Serve society's needs for weather and water
- Support the nation's commerce with information for safe, efficient and environmentally sound transportation
- Provide critical support for the NOAA mission

### **CIMSS Research Themes:**

- Satellite Meteorology Research and Applications
- Satellite Sensors and Techniques

### **Objective**

To develop a suite of products that will offer advanced cloud detection and retrievals of cloud properties utilizing the GOES-R ABI instrument.

### **Project Overview**

The Cloud AWG has developed five algorithms that generate fourteen independent cloud products. These include the clear sky mask, cloud top phase, cloud top height, cloud top pressure, cloud top temperature, and both day and nighttime cloud microphysical properties.



## Milestones with Summary of Accomplishments and Findings

The focus of the Cloud AWG this reporting period was maintaining and updating the various algorithms, validating the updated algorithms and supporting the GOES-R Ground Segment System Prime, Harris Corporation, in their implementation of the cloud algorithms. This primarily meant observing the cloud products produced from the Ground System and evaluating their operational readiness.

The various cloud algorithms have been, or are in the process of, being adapted for sensors other than ABI. These include the current GOES GVAR sensors, COMS, Himawari-8 (ABI like imager), Meteosat, MODIS, VIIRS as well as making sure that the baseline algorithms work on the GOES-16 Advanced Baseline Imager (ABI) datasets. In addition, work began on evaluating cloud algorithm output from the GOES-16 Ground System (GS) starting in early 2017 and continued throughout the post launch period.

### Cloud Mask

The major effort during this reporting period was the GOES-R Peer/Stakeholder Product Validation Review (PS-PVR) for the Binary Cloud Mask (BCM) from the GS. The ABI L2+ Clear Sky Mask, Readiness, Implementation and Management Plan (RIMP) document defined several Post-Launch Product Tests (PLPTs) for each product maturity level. Table 1 shows the two PS-PVRs which were conducted and their grades.

**Table 1. BCM PS-PVRs results.**

Maturity Level	Date	Disposition
Beta	04/19/2017	Passed
Provisional	02/16/2018	Passed

Several issues were found and addressed with the BCM during the post launch checkout as the PLPTs were being run. This included fixing several cloud mask tests which were not performing as expected as well as updating the cirrus reflectance test. This was crucial as the 1.4  $\mu\text{m}$  channel is a new channel on ABI and this was the first time the team could evaluate its performance. Figure 6 shows an example BCM from March 3, 2017 at 1925 UTC.

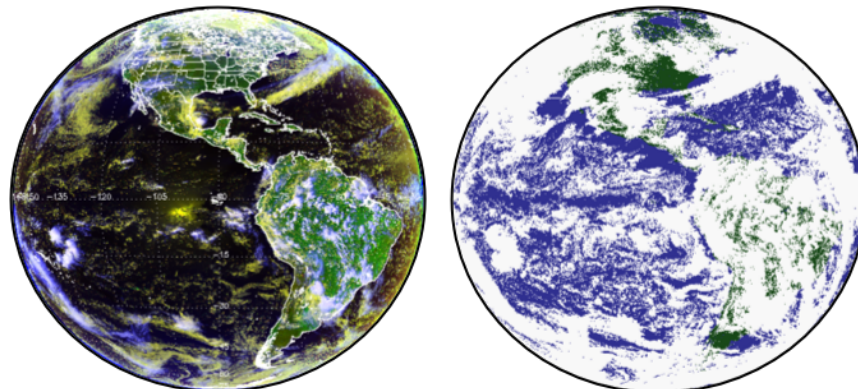

**Figure 6. Example baseline GOES-16 ABI RGB (left) and BCM (right) on March 3, 2017 at 1925 UTC.**

One PLPT required that the BCM probability of cloud detection be 87% when compared to CALIOP.

Table 2 shows how the BCM improved from Beta maturity to Provisional.



**Table 2. CALIOP - BCM results.**

Maturity Level	Detection Probability	False Detection Probability
BCM Provisional	0.903	0.032
BCM Beta	0.891	0.064

The next (and final) maturity level will be Full (later 2018). There may still be improvements in the detection probability if some current known issues are addressed. Some current issues include: false cloud due to fresh snow missing from the ancillary snow mask data, blockiness around land and unmarked inland water, false clouds around coastlines, false clouds over SST gradients, missed stratus clouds at night, terminator performance and Band 2 calibration issues.

**Cloud Top Phase**

The major effort during this reporting period was the GOES-R PS-PVR for the cloud top phase product. Table 3 contains the results of the two PS-PVRs conducted during this period that addressed the PLPTs defined by the ABI RIMP document.

**Table 3. Cloud Top Phase PS-PVR results.**

Maturity Level	Date	Disposition
Beta	05/16/2017	Passed
Provisional	02/22/2018	Passed

No major issues were observed by the AWG cloud team. An example of the cloud top phase product applied to the full disk is shown in Figure 7.

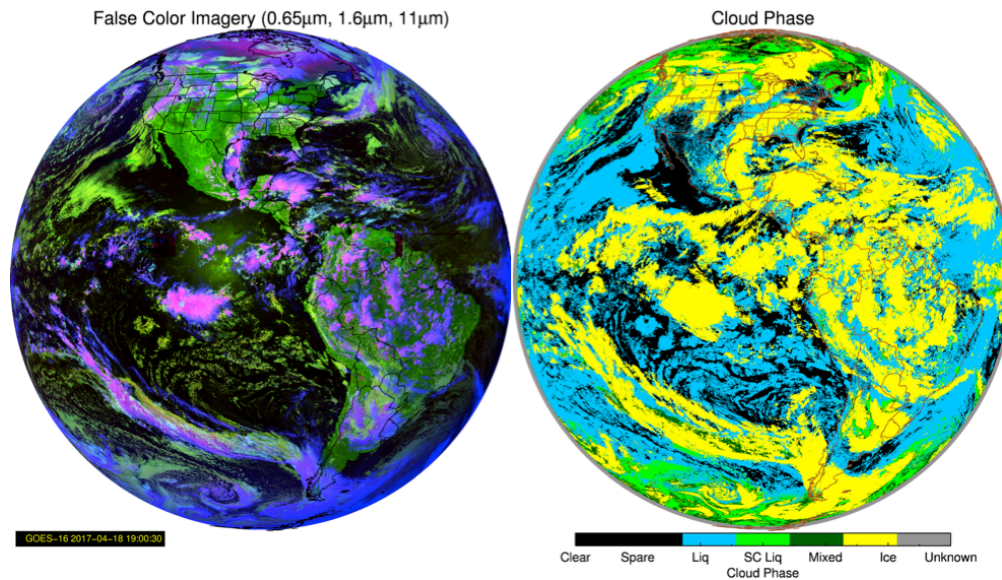

**Figure 7. Cloud Top Phase example from April 18, 2017 at 19:00 UTC.**

One PLPT required the cloud top phase to have a measurement accuracy of 80% correct classification for cloud phase when compared to the CALIOP cloud top phase product. Figure 8 contains the results of the ABI cloud top phase validation analysis and shows the product comfortably meets the specification for all cloud optical depths.

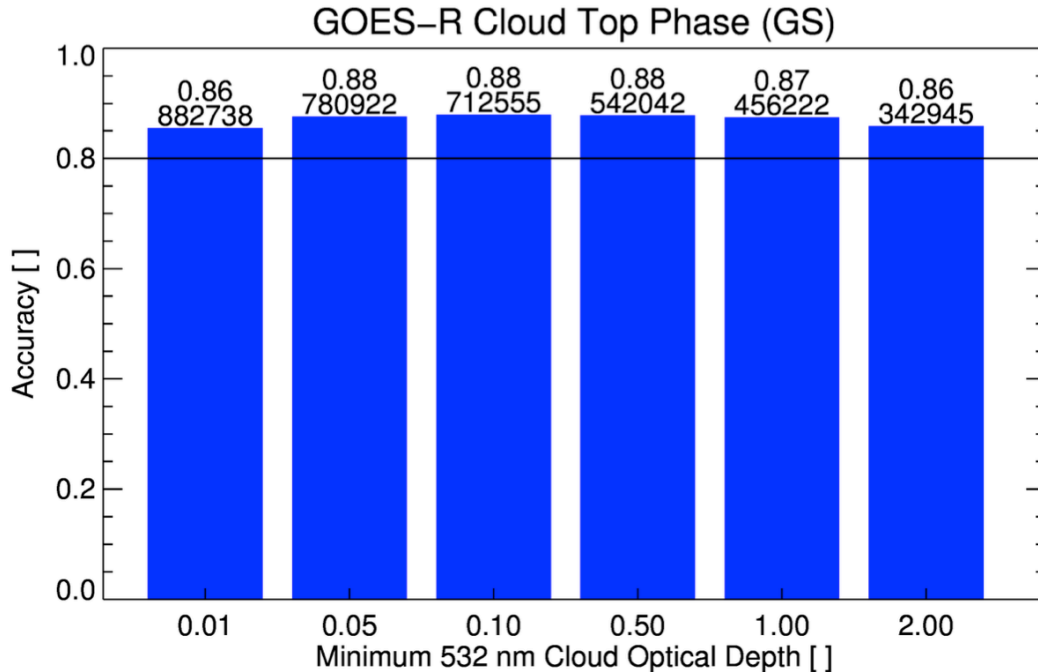

**Figure 8. GOES-R Cloud Top Phase validation compared to the CALIOP cloud top phase product, as a function of cloud optical depth obtained from CALIOP. The horizontal black line represents the accuracy requirement defined by the ABI RIMP.**

The AWG cloud team has found some situational performance issues that impact downstream products and may impact downstream user applications. One such issue is that liquid water cloud edges are sometimes misclassified as ice clouds. Another issue is developing cumulus clouds and mid-level clouds are too often classified as ice. These may contribute to the over-estimation of the cloud height produced by downstream algorithms. Previously published research has shown that these issues can be mostly mitigated by incorporating near-infrared measurements. However, the use of near-infrared measurements is complicated by highly variable surface reflectance and sun geometry and will likely contribute to inconsistencies in the cloud top phase product through the diurnal cycle. Future work may be needed to mitigate some of the issues, but further guidance on whether to proceed with algorithm enhancements will be necessary.

### **Cloud Top Parameters**

The major effort during this reporting period was the GOES-R PS-PVR for the Cloud Top Parameters (height, pressure, temperature). Collectively these parameters will be represented by CTP. The cloud top pressure will be designated as CTP. The RIMP for ABI L2+ CTPs defined the PLPTs needed to reach the beta and full product maturity. Table 4 shows the maturity level reached during this period.

**Table 4. CTP PS-PVR results.**

Maturity Level	Date	Disposition
Beta	05/16/2017	Passed
Provisional	02/16/2018	Passed

The cloud team did not observe many issues with the CTPs. Figure 9 shows an example full disk set of CTP products.



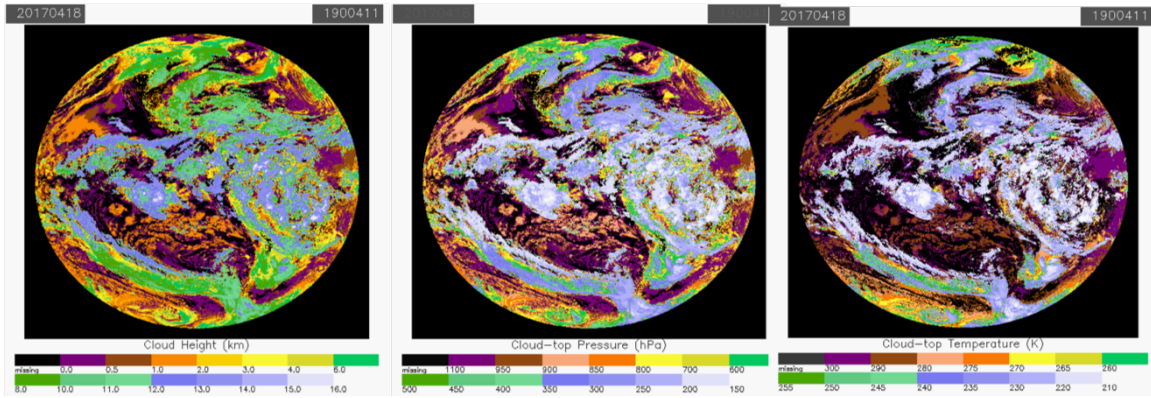

Figure 9. CTP examples from April 18, 2017 at 19:00 UTC. CTH left, CTp middle, and CTT right.

One of the required PLPTs involved comparing CALIOP cloud products to the CTPs. Table 5 shows various CALIOP CTp statistics. To meet specifications, the Accuracy needs to be within 50 hPa and the Precision within 150 hPa.

Table 5. CALIOP - CTp accuracy and precision results for 10 days in January 2018.

Cloud Filter	Count/Fraction	Accuracy (hPa)	Precision (hPa)	% within spec
None	265507/1.0	77	205	77
COD > 1	179860/0.68	51	172	81
+ Phase Match	145441/0.55	32	129	88
+ Single Layer	82665/0.31	-10	106	92
COD + Single	96793/0.36	-16	119	90
Phase + Single	112263/0.42	12	140	89

For the scenarios which are consistent with the cloud retrieval assumptions (COD, known phase, single layer clouds) the GS ACHA works. However, false or missed clouds in the BCM will have an impact on the CTPs. The Phase algorithm tends to be in error for high clouds. ACHA will underestimate the height of these clouds.

The Derived Motion Winds (DMW) team is reliant on accurate CTP products in their algorithms. From the DMW Provisional discussion, there are sub optimal cloud height assignments causing precision specifications to be missed in the 350 – 500 hPa layer, negative speed biases in the upper levels, and positive speed biases in the middle levels. A library of outlier cases is being built by the DMW team which will allow the Cloud team to address the height assignment issues. However, the CTP products still need to attain a balance between meeting CTP requirements, as well as providing accurate products for the DMW team. Future work will include diagnosing the reasons why these outlier cases are failing to deliver accurate cloud heights during the retrieval process.

### **DNCOMP**

The major effort during this reporting period was the GOES-R PS-PVR for the Cloud Top Parameters Day/Night Cloud Optical and Microphysical Properties (cloud optical depth and cloud particle size). Collectively these parameters will be represented by COMP with DCOMP during the day and NCOMP during the night. The cloud optical depth will be designated as COD and the cloud particle size as CPS. The RIMP for ABI L2+ COMPs defined the PLPTs needed to reach the beta and full product maturity. Table 6 shows the maturity level reached during this period.



**Table 6. COMP PS-PVR results.**

Maturity Level	Date	Disposition
Beta	06/08/2017	Passed (COD and CPS)
Provisional	02/22/2018	Passed (COD only)

The cloud team did not observe many issues with the COD. Figure 10 show example full disk images of COD for both DCOMP and NCOMP products. There were several concerns related to

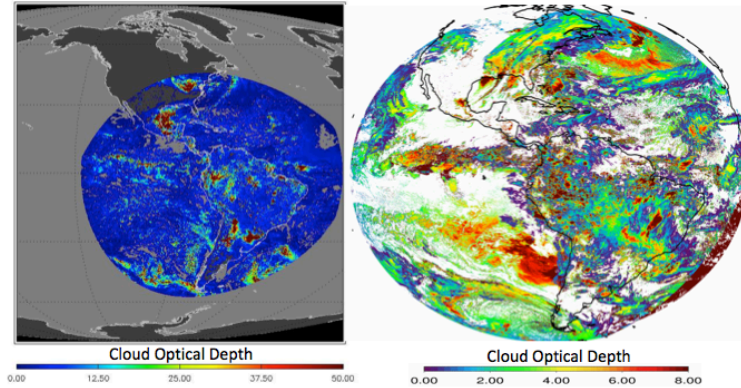

**Figure 10. COD examples from DCOMP on January 24, 2018 at 17:00 UTC and NCOMP on January 12, 2018 at 08:00 UTC.**

CPS that resulted in a delay in designating CPS as having reached provisional status. Figure 11 shows an example full disk image of CPS for both DCOMP and NCOMP products. Note that the DCOMP results are for a smaller portion of the disk because its COD results are valid only for

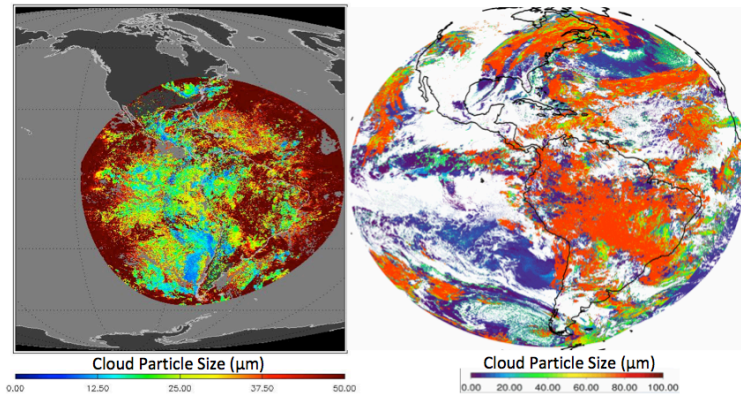

**Figure 11. CPS examples from DCOMP on January 24, 2018 at 17:00 UTC and NCOMP on January 12, 2018 at 08:00 UTC.**

viewing zenith angles  $< 65^\circ$ . The primary concerns are related to unusually large DCOMP CPS at higher viewing angles and in sunglint areas. These areas of large CPS are also seen in products obtained from the CONUS PLPT domain. It was noted that these areas did not occur in the Beta review and do not occur in DCOMP results obtained using analogous software in the CLAVR-x framework, hence a solution to the problem is thought to lie in the recent update to the ground system. A strategy and timeline were developed to identify any updates or changes to the ground system software that might have created the CPS issues.

One of the required PLPTs involved comparing independently obtained CODs to the COMP CODs. Table 7 shows the results from comparisons of DCOMP CODs to MODIS-derived CODs



for water and ice clouds and from comparisons of NCOMP ice cloud CODs to CALIOP CODs. To meet specifications for water clouds, the accuracy needs to be within 20% for DCOMP and and the Precision within 2 or 20%. Similarly, for ice clouds the accuracy needs to be within 3 or 30% for DCOMP or 20% for NCOMP. Both DCOMP and NCOMP meet those requirements, Although the MODIS results shouldn't be considered truth or completely independent and the CALIOP results are highly filtered, both DCOMP and NCOMP results are encouraging.

**Table 7. Statistics from COMP COD validations performed with MODIS (DCOMP) and CALIOP (NCOMP). 10 days in January 2018. MODIS comparisons use 34 days of data beginning January 10, 2018 and the CALIOP comparisons use 16 days of data beginning January 9, 2018.**

Cloud Property	Required Accuracy	Measured Accuracy	Required Precision	Measured Precision
DCOMP Water Cloud COD	2 or 20%	8.1%	2 or 20%	N/A
DCOMP Ice Cloud COD	3 or 30%	8.3%	3 or 30%	N/A
NCOMP Ice Cloud COD	20%	5.5%	0.5 or 50.7%	Max of 0.8 or 35%

Due to NCOMP being limited to  $1 \leq \text{COD} \leq 5$ , reliable validation sources for water cloud COD have not been identified. Similarly, CPS validation sources are quite limited and given DCOMP results from the ground system were inconsistent with CLAVR-x CPS results, CPS remains at beta.

The impact of incorrect input to both DCOMP and NCOMP were explored. Incorrect Cloud Top Phase and/or Cloud Top Temperature do impact the COMP retrievals, as do any errors in other inputs, including NWP profiles. Future work will include further DCOMP COD comparisons with MODIS and further NCOMP COD comparisons with CALIOP. DCOMP CPS, once any ground system errors are identified, will also be compared to MODIS. Both DCOMP and NCOMP LWP products have been compared to AMSR-2 as indirect methods of assessing both COD and CPS reliabilities and those comparisons will continue.

Validation of the current and updated algorithms is important to ensure the algorithms perform as expected during the post-launch check out for GOES-R. The Cloud AWG has extensively used other satellite sensors, such as spaceborne lidars, (CALIPSO), passive microwave satellite sensors (AMSU, AMSR-E), ground based lidars (HRSL), ground microwave profilers (MWR at ARM site) and passive imagers (MODIS, AVHRR), as independent validation data sources. In addition, the Cloud AWG has made extensive use of the lidar (CALIOP) on-board CALIPSO to tune the cloud mask for the least number of false detections. The Cloud AWG team also continues to work with the other Algorithm Working Groups, such as the Derived Motion Winds AWG, as well as other groups to continue to validate and improve the algorithms. Automated validation tools were also worked on in the previous year so that there can be automatic validation of the various cloud algorithms after launch.

In addition to offline validation studies, the cloud algorithms have been used in a near-real-time field campaigns as well as international workshops on cloud properties. For example, the cloud top height algorithm, which also relies on the cloud mask and type/phase algorithms, will be used during NOAA Shout Program (Sensing Hazards with Operational Unmanned Technology). Cloud heights are used to aid in flight path decisions for the Global Hawk Unmanned Aerial Vehicle (UAV) over and around the path of tropical cyclones.



As of early March 2018, all of the cloud algorithms, with the exception of Cloud Particle Size, reached provisional maturity, meaning that the algorithms will be made available to users. However, this does not mean that the algorithms are considered operational and will continue to be improved on. In the case of CPS, the Cloud AWG continues to work closely with the GOES-R Program on figuring out the issue, which is limited to just the Ground System.

In 2018, the Cloud AWG will continue to improve the various cloud algorithms, support the GS in their effort as they produce output from the baseline cloud algorithms, provide analysis on the output from the GS in support of operational status for GOES-16 and evaluate the products for GOES-17, continue development on the automated tools for the validation of the cloud algorithm, support international validation efforts and continue support of near-real-time usage of the cloud algorithms by field campaigns.

### **Publications and Conference Reports**

Feltz, Wayne; Pierce, R. Bradley; Eloranta, Ed; Schmidt, Sebastian; Heidinger, Andrew; Kondragunta, Shobha; Walther, Andi and LeBlance, Samuel. GOES-R cloud and aerosol validation during the NSF DC3 field mission. NOAA 2013 Satellite Conference for Direct Readout, GOES/POES, and GOES-R/JPSS Users, College Park, MD, 8-12 April 2013. NASA, Goddard Space Flight Center, GOES-R Program Office, Greenbelt, MD, 2013, poster presentation.

Hamann, U.; Walther, A.; Baum, B.; Bennartz, R.; Bugliaro, L.; Derrien, M.; Francis, P. N.; Heidinger, A.; Joro, S.; Kniffka, A.; Le Gleau, H.; Lockhoff, M.; Lutz, H.-J.; Meirink, J. F.; Minnis, P.; Palikonda, R.; Roebeling, R.; Thoss, A.; Platnick, S.; Watts, P. and Wind, G.. Remote sensing of cloud top pressure/height from SEVIRI: Analysis of ten current retrieval algorithms. *Atmospheric Measurement Techniques*, Volume: 7, Issue: 9, 2014, pp.2839-2867

Heidinger, Andrew. Algorithm Theoretical Basis Document: ABI cloud height. Version 2.0. NOAA, NESDIS, Center for Satellite Applications and Research, 2011.

Heidinger, Andrew. Algorithm Theoretical Basis Document: ABI cloud mask. Version 2.0. NOAA, NESDIS, Center for Satellite Applications and Research, 2011.

Heidinger, Andrew K.. Applicability of GOES-R AWG cloud algorithms for JPSS/VIIRS. Annual Symposium on Future Operational Environmental Satellite Systems, 7th, Seattle, WA, 23-27 January 2011. American Meteorological Society (AMS), Boston, MA, 2011, abstract only.

Heidinger, Andrew K.. Performance of the NOAA AWG cloud height algorithm applied to current geostationary and polar orbiting imagers. International Winds Workshop, 12th, Copenhagen, Denmark, 15-20 June 2014. University of Copenhagen, Copenhagen, Denmark, 2014, abstract only.

Heidinger, Andrew K.; Evan, Amato T.; Foster, Michael J. and Walther, Andi. A naive Bayesian cloud-detection scheme derived from CALIPSO and applied within PATMOS-x. *Journal of Applied Meteorology and Climatology*, Volume: 51, Issue: 6, 2012, pp.1129-1144.

Heidinger, Andrew K.; Wanzong, S. and Walther, A.. Analysis of convective clouds viewed from GOES during DC3. Conference on Severe Local Storms, 27th, Madison, WI, 2-7 November 2014. American Meteorological Society, Boston, MA, 2014, abstract only.



Heidinger, Andrew; Baum, Brian and Roebeling, Rob. The Cloud Retrieval Evaluation Workshop (CREW). Meeting on the Intercomparison of Satellite-based Volcanic Ash Retrieval Algorithms within WMO SCOPE-Nowcasting, Madison, WI, 28 June-2 July 2015. University of Wisconsin-Madison, Space Science and Engineering Center, Madison, WI, 2015, PowerPoint presentation.

Heidinger, Andrew; Pavolonis, Michael; Walther, Andi; Heck, Pat; Minnis, Pat and Straka, William. GOES-R AWG product validation tool development: Cloud products. GOES-R AWG Annual Meeting, Fort Collins, CO, 14-16 June 2011. NASA, Goddard Space Flight Center, GOES-R Program Office, Greenbelt, MD, 2011.

Heidinger, Andrew; Walther, Andi; Foster, Mike and Ackerman, Steve. State of the NOAA AWG cloud algorithms. 2011 EUMETSAT Cloud Retrieval Evaluation Workshop, 3rd, (CREW-3), Madison, WI, 15-18 November 2011. University of Wisconsin-Madison, Space Science and Engineering Center, Cooperative Institute for Meteorological Satellite Studies (CIMSS), Madison, WI, 2011, abstract only.

Heidinger, Andrew; Wanzong, Steve and Walther, Andi. Status of cloud products from HIMAWARI-8 AHI. 2015 GOES-R/JPSS OCONUS Satellite Proving Ground Technical Interchange Meeting, Anchorage, AK, 12-15 May 2015. National Oceanic and Atmospheric Administration (NOAA), 2015.

Kelly, Michael; Wu, Dong; Yee, Jeng-Hwa; Boldt, John; Demajistre, Robert; Reynolds, Edward; Tripoli, Gregory; Oman, Luke; Prive, Nikki; Heidinger, Andrew and Wanzong, Steve. C3Winds: A novel 3D wind observing system to characterize severe weather events. AGU Fall Meeting, San Francisco, CA, 14-18 December 2015. American Geophysical Union, Washington, DC, 2015, abstract only; Abstract A51G-0150.

Kinne, Stefan; Stubenrauch; Rossow, W. B.; Pearl, C.; Heidinger, A.; Walther, A.; Guignard, A.; Ackerman, S.; Platnick, S.; Maddux, B.; Minnis, P.; Sun-Mack, S.; DiGirolamo, L.; Menzies, A.; Menzel, P.; Olsen, E.; Riedi, J.; Zeng, S.; Winker, D.; Getzewich, B.; Chepfer, H.; Gesana, G.; Poulsen, C. and Sayer, A.. GEWEX cloud assessment: A review. 2011 EUMETSAT Cloud Retrieval Evaluation Workshop, 3rd, (CREW-3), Madison, WI, 15-18 November 2011. University of Wisconsin-Madison, Space Science and Engineering Center, Cooperative Institute for Meteorological Satellite Studies (CIMSS), Madison, WI, 2011, abstract only.

Madani, Houria; Carr, James; Heidinger, Andrew and Wanzong, Steve. Inter-comparisons between radiometric and geometric cloud top height products. AGU Fall Meeting, San Francisco, CA, 14-18 December 2015. American Geophysical Union, Washington, DC, 2015, abstract only; Abstract A33E-0220.

Mecikalski, John R.; Jewett, C. P.; Weygandt, S.; Smith, T. L.; Heidinger, A. K.; Straka, W. and Benjamin, S.. Convective initiation of 0-6 hr storm nowcasting for GOES-R. Conference on Weather Analysis and Forecasting, 26th, and Conference on Numerical Weather Prediction, 22nd, Atlanta, GA, 2-6 February 2014. American Meteorological Society, Boston, MA, 2014, abstract only.

Monette, Sarah A.; Velden, C. S.; Heidinger, A. K.; Zipser, E. J.; Cecil, D. J.; Black, P. G. and Braun, S. A.. Validation of Automated Cloud Height Algorithm (ACHA) cloud top heights in tropical cyclones using observations from the NASA Global Hawk. Conference on Hurricanes and Tropical Meteorology, 31st, San Diego, CA, 31 March-4 April 2014. American



Meteorological Society, Boston, MA, 2014, abstract only.

Roebeling, R.; Baum, B.; Bennartz, R.; Hamann, U.; Heidinger, A.; Thoss, A. and Walther, A.. Outcome of the Third Cloud Retrieval Evaluation Workshop. IRS 2012: International Radiation Symposium, Berlin, Germany, 6-10 August 2012. Radiation Processes in the Atmosphere and Ocean (IRS2012). American Institute of Physics, Melville, NY, 2013, pp.416-419. Reprint # 7142.

Roebeling, R.; Baum, B.; Bennartz, R.; Hamann, W.; Heidinger, A.; Melrinc, J. F.; Stengel, M.; Thoss, A.; Walther, A. and Watts, P.. Outcome of the fourth Cloud Retrieval Evaluation Workshop. 2014 EUMETSAT Meteorological Satellite Conference, Geneva, Switzerland, 22-26 September 2014. Abstracts. European Organization for the Exploitation of Meteorological Satellites (EUMETSAT), Darmstadt, Germany, 2014, abstract only.

Roebeling, Rob; Baum, Bryan; Bennartz, Ralf; Hamann, Ulrich; Heidinger, Andy; Thoss, Anke and Walther, Andi. Evaluating and improving cloud parameter retrievals. Bulletin of the American Meteorological Society, Volume: 94, Issue: 4, 2013, ES41-ES44.

Roebeling, Rob; Baum, Bryan; Bennartz, Ralf; Hamann, Ulrich; Heidinger, Andrew; Meirink, Jan Fokke; Stengle, Martin; Thoss, Anke; Walther, Andi and Watts, Phil. Summary of the fourth Cloud Retrieval Evaluation Workshop. Bulletin of the American Meteorological Society, Volume: 96, Issue: 4, 2015, ES71-ES74.

Schmit, Timothy J.; Goodman, Steven J.; Gunshor, Mathew M.; Sieglaff, Justin; Heidinger, Andrew K.; Bachmeier, A. Scott; Linstrom, Scott S.; Terborg, Amanda; Feltz, Joleen; Bah, Kaba; Rudlosky, Scott; Lindsey, Daniel T.; Rabin, Robert M. and Schmidt, Christopher C.. Rapid refresh information of significant events: Preparing users for the next generation of geostationary operational satellites. Bulletin of the American Meteorological Society, Volume: 96, Issue: 4, 2015, pp.561-576, supplement

Schreiner, Anthony J.; Menzel, W. Paul; Straka, William and Heidinger, Andrew. Comparison of CO<sub>2</sub> and H<sub>2</sub>O Atmospheric Motion Vector height assignment techniques using the GOES-13 imager. International Winds Workshop, 11th, Auckland, New Zealand, 20-24 February 2012. EUMETSAT, Darmstadt, Germany, 2012.

Schreiner, Anthony; Menzel, W. Paul; Straka, William and Heidinger, Andy. Comparing CO<sub>2</sub>/IRW and H<sub>2</sub>O/IRW CTPs. International Winds Workshop, 11th, Auckland, New Zealand, 20-24 February 2012.

Walther, A. and Heidinger, A. K.. The consistency of cloud climatologies derived from several sensors. AGU Fall Meeting, San Francisco, CA, 5-9 December 2011. American Geophysical Union, Washington, DC, 2011, abstract only; Abstract A13B-0275.

Walther, Andi and Heidinger, A.. The Daytime Cloud Optical and Microphysical Properties (DCOMP) algorithm. Conference on Satellite Meteorology, Oceanography and Climatology, 18th, and Joint AMS-Asia Satellite Meteorology Conference, 1st, New Orleans, LA, 22-26 January 2012. American Meteorological Society, Boston, MA, 2012, abstract only.

Walther, Andi and Heidinger, Andrew K.. Implementation of the Daytime Cloud Optical and



Microphysical Properties algorithm (DCOMP) in PATMOS-x. Journal of Applied Meteorology and Climatology, Volume: 51, Issue: 7, 2012, pp.1371-1390.

Walther, Andi; Heidinger, Andrew and Park, Chang-Hwan. Sources of error in satellite derived cloud products. 2011 EUMETSAT Cloud Retrieval Evaluation Workshop, 3rd, (CREW-3), Madison, WI, 15-18 November 2011. University of Wisconsin-Madison, Space Science and Engineering Center, Cooperative Institute for Meteorological Satellite Studies (CIMSS), Madison, WI, 2011, abstract only.

Walther, Andi; Straka, William and Heidinger, Andrew K.. Advanced Baseline Imager (ABI) Algorithm Theoretical Basis Document for Daytime Cloud Optical and Microphysical Properties (DCOMP) Version 2.0. NOAA, NESDIS, Center for Satellite Applications and Research, 2011

Wu, Dong L; Baum, Bryan A.; Choi, Yong-Sang; Foster, Michael J.; Kalsson, Karl-Goran; Heidinger, Andrew; Poulsen, Carolin; Pavolonis, Michael; Riedi, Jerona; Roebeling, Robert; Sherwood, Steven; Thoss, Anke and Watts, Philip. Toward global harmonization of derived cloud products. Bulletin of the American Meteorological Society, Volume: 98, Issue:2, 2017, ES49-ES52. Reprint #7907.

#### **4.3 Active Fire/Hot Spot Characterization**

**CIMSS Task Leader: Chris Schmidt**

**NOAA Collaborators: Ivan Csiszar, Wilfrid Schroeder, Yunyue Yu**

**Budget: \$100,000**

##### **NOAA Long Term Goals:**

- Climate Adaptation and Mitigation
- Weather-Ready Nation

##### **NOAA Strategic Goals:**

- Serve society's needs for weather and water
- Understand climate variability and change to enhance society's ability to plan and respond
- Support the nation's commerce with information for safe, efficient and environmentally sound transportation
- Provide critical support for the NOAA mission

##### **CIMSS Research Themes:**

- Satellite Meteorology Research and Applications
- Satellite Sensors and Techniques
- Environmental Models and Data Assimilation
- Education and Outreach

##### **Objective**

This effort has adapted the current Global Wildfire Automated Biomass Burning Algorithm (WFABBA) to GOES-R ABI.

##### **Project Overview**

This activity has been building on historical and current expertise at CIMSS in fire algorithm development for the GOES Imager and the global geostationary fire observation network (MSG,



MTSAT, COMS, etc). CIMSS revised the WFABBA to address GOES-R ABI observational requirements utilizing the improved fire monitoring capabilities on GOES-R. This work is now focused on demonstrating and validating the GOES-R ABI Fire Detection and Characterization Algorithm (FDCA) using GOES-16 data. This effort includes collaboration with MODIS and NPOESS VIIRS fire product development experts to maximize future use of multiple data sources (geo and leo) that take advantage of the strengths of each system to create improved fused fire products. The collaboration also has led to the development of innovative “deep-dive” validation tools. This activity ensures enhanced future geostationary fire detection, diurnal monitoring, and characterization in the GOES-R era. The validation component of this work is performed in conjunction with Dr Wilfrid Schroeder from NOAA. Work from this project is also used in GOES-R training, primarily for NWS forecasters and broadcasters utilizing various media outlets.

### **Milestones with Summary of Accomplishments and Findings**

The primary task for the past year was to assess performance of the FDCA and send updates as needed to ASSISTT and the ground system contractor. The initial performance assessment was performed primarily through visual inspection of algorithm outputs next to raw ABI data. Performance was also assessed with the deep-dive analysis tool developed by Dr Schroeder which uses high resolution fire data, primarily from Landsat, to compare to ABI detections. The deep-dive tool is our best method of assessing commission and omission fire detection errors, but is constrained by the lack of such data. That work has demonstrated high correct detection rates for the highest confidence fire category (95% in the most recent estimate, a 5% false alarm rate).

Beta Maturity was reached in late May 2017, with the understanding at the time that there were known issues. There were ground system configuration problems that caused a lot of lost data over North America in the summer, in blocks where the algorithm was spending a lot of time analyzing potential fire pixels. This was due to the short lifetime of band 7 data in the ground system’s “data fabric” and has been since resolved. As we entered fall a large number of false alarms appeared in South America, presenting a serious problem and contributing to the long runtime of the algorithm. The primary cause was found to be the background pixel screen – it was too strict and not accounting for the larger band 7 and band 14 brightness temperature differences in non-fire scenes when using ABI. Once corrected, the false alarms dropped tremendously. It appears that the dropped block problem somewhat masked this issue in North America last summer. Figure 12 illustrates the impact of the correction on the fire product. The top row shows ABI data for a sample day in November 2017 over Brazil. The middle row contains output FDCA masks and the bottom row shows which pixels were allowed in the background calculation (the last two boxes are essentially the same). The FDCA masks show a marked decrease in detected fires (see legend at left) and “background calculation failed” pixels, the frequency of which can be an indicator for problems such as the one remedied here.

With the major fix and a handful of other smaller fixes, the algorithm achieved Provisional Maturity Status on schedule at the end of March 2018. “Readme” files were created for both the Beta and Provisional Maturity levels.

While not strictly a part of the AWG project, Chris Schmidt participated in GOES-16 Short Courses at the AMS Broadcast Meteorology Conference in Kansas City, CMOS in Toronto, NOAA’s Satellite Conference in New York City, the joint 2018 AMS Annual Meeting/Broadcast Meteorology Conference in Austin, TX. He also presented a joint GOES-16/JPSS fires example at NWA in Garden City, CA and presented the GOES\_16 portion of satellite fire detection training for IMETs in Boise, ID in March 2018. These training activities, particularly those that





reach NWS forecasters and the broadcast community, are critical to expanding use and knowledge of the FDCA.

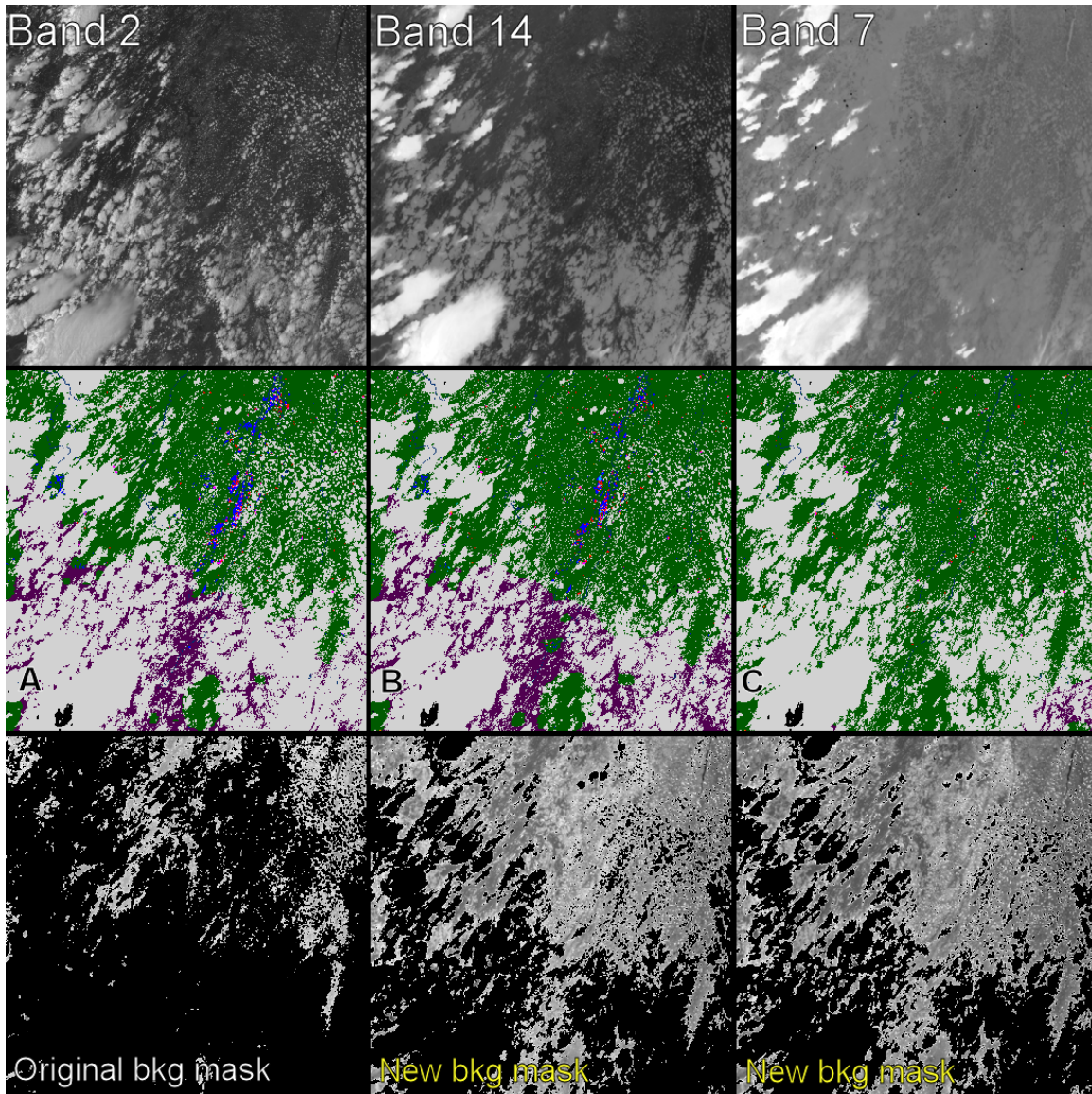

Figure 12. Comparison of status at Beta vs Provisional Maturity. Top row: ABI bands; Middle: A) Old ground system output mask, B) Old CIMSS output mask, C) Provisional maturity output mask; Bottom: Bkg calc pixels before/after fix.

#### 4.4 GOES-R Legacy Atmospheric Profile (LAP), Total Precipitable Water (TPW), and Atmospheric Instability Indices

CIMSS Task Leader: Jun Li

CIMSS Support Scientists: Yong-Keun Lee, Kevin Baggett, Richard Dworak, and William Straka, Zhenglong Li

NOAA Collaborators: Tim Schmit, Walter Wolf

Budget: \$250,000



### **NOAA Long Term Goals:**

- Climate Adaptation and Mitigation
- Weather-Ready Nation

### **NOAA Strategic Goals:**

- Serve society's needs for weather and water
- Understand climate variability and change to enhance society's ability to plan and respond
- Support the nation's commerce with information for safe, efficient and environmentally sound transportation
- Provide critical support for the NOAA mission

### **CIMSS Research Themes:**

- Satellite Meteorology Research and Applications
- Satellite Sensors and Techniques

### **Objective**

The objective is to develop and validate GOES-R series operational legacy atmospheric profile (LAP) algorithms/products to meet the users' requirements.

### **Project Overview**

The main focus of this project is to develop the legacy atmospheric profile (LAP) algorithm for the next generation Geostationary Operational Environmental Satellites (GOES-R series) Advanced Baseline Imager (ABI) (Schmit et al. 2005; 2017) product generation and validation. The algorithm retrieves atmospheric temperature and moisture profiles and the derived products including total precipitable water (TPW), layered precipitable water (PW), lifted index (LI), convective available potential energy (CAPE), total totals index (TT), Showalter index (SI), and the K-index (KI) from the clear sky infrared (IR) radiances. This project requires CIMSS scientists to develop and validate the GOES-R series LAP algorithm to be able to process high temporal and spatial resolution ABI data efficiently. This project provides prototype science codes to the GOES-R series algorithm integration team (AIT) for algorithm integration and helps the system provider to implement the algorithm and prototype codes into the GOES-R series ground system. CIMSS scientists also evaluate and validate the GOES-R series LAP products to assure that the GOES-R series legacy atmospheric temperature and moisture profiles, TPW, LI, CAPE, TT, SI and KI products meet the science/user requirements and operational applications.

### **Milestones and Summary of Accomplishments and Findings**

The major accomplishments are listed in the following, a full annual report containing more details on GOES-R series AWG LAP progress in 2017 will be provided to GOES-R series AWG manager and sounding team Chair in April 2017.

(1) CIMSS near real-time LAP product validation "tools"(soundingval.ssec.wisc.edu) have been further developed to include GOES-16, now both GOES-16 baseline and GOES Sounder LAP products are included in the webpage. The operational ABI LAP products are monitored daily with reference datasets at this validation tool, and the ABI LAP products under near real-time monitoring include those from disk, CONUS and mesoscale regional observations.

(2) Performed intensive validation of GOES-16 LAP products during the GOES-R Post-Launch Test (PLT) and Extended Validation periods. Executed the GOES-16 LAP validation activities defined in the GOES-R L2 Product Readiness, Implementation and Management Plan (RIMP)



aimed at achieving Beta and Provisional levels of product maturity. Prepared and delivered presentations for Peer-Stakeholder Product Validation Reviews (PS-PVR). Followed dates outlined in the GOES-16 validation plan, the LAP team passed both Beta and provisional reviews for LAP baseline products. The LAP products validated include: atmospheric temperature and moisture profiles, total precipitable water (TPW), layer precipitable water (PW), lifted index (LI), convective available potential energy (CAPE), total totals index (TT), Showalter index (SI), and the K-index (KI). The reference data used in validation include ECMWF analysis, GDAS, RAOBs, ARM site microwave radiometer TPW measurements, AMSR-2 TPW over ocean, field campaign measurements, and GPS Met TPW observations.

Figure 13 shows TPW from both GOES-16 and GOES-15 (left panel: GOES-16 full disk; right panel: GOES-16 CONUS) for 10 UTC 2017.11.03 (307). The smooth transition from GOES-15 to GOES-16 indicates that the two products (GOES-15 and GOES-16) have the similar data quality, while GOES-16 has much larger spatial coverage and higher temporal resolution.

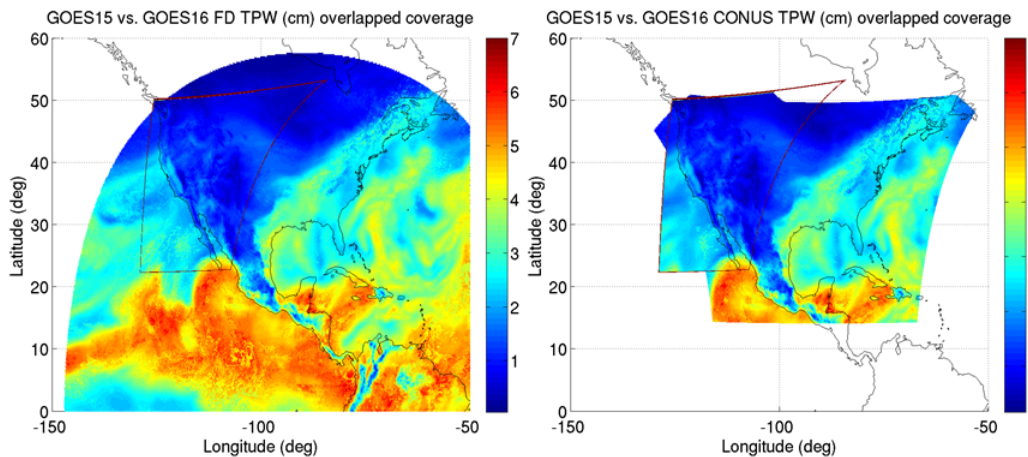

**Figure 13. TPW from both GOES-16 and GOES-15 (left panel: GOES-16 full disk; right panel: GOES-16 CONUS) for 10 UTC 2017.11.03 (307).**

(3) Participated in 2017 HWT spring experiment, the GOES-16 baseline clear sky only LAP products were accessed for 2017 HWT experiments and forecast applications. Feedback from forecasters indicated that gradients are useful for situation awareness; here is the list of some comments/feedback from forecasters:

- “Yes, CAPE, LI, and PW. Actually all were useful in showing a gradient in the same location. More specifically, higher CAPE, LI, and PW were seen across eastern MT and western ND, with then a transition to lower values towards south central SD. This ended up being where convection began to weaken.”
- “For derived, I found the total PW to be very helpful in representing the environmental conditions, which did have an impact on how convection would evolve. LI was not bad either. The winds were really useful, mainly for the same reason as the PW in analyzing the environment.”
- “I used the Total Precipitable Water Product which was valuable in discerning where the deeper moisture was located. The CAPE product underestimated the amount of instability. The GOES derived winds helped to verify the placement of the upper jet and a mid-level speed max.”
- “The CAPE/LI products were really helpful in highlighting the areas of focus on a Situational Awareness basis. While the values for CAPE were generally lower than



expected, the areal extent and gradients were generally in line with what I would have expected.”

Although ABI baseline LAP products were useful in the 2017 HWT; the usage was limited compared to the previous years of HWT with all-sky LAP products from GOES Sounder. It is suggested to develop all-sky ABI LAP products and make them available in AWIPS in near real-time, and to produce the layered PWs (LPWs) at three atmospheric layers for forecast applications.

(4) Developed collocated matchup file between GOES-16 and reference data. The GOES-16 data in the matchup file contains L1B, cloud mask and LAP, this matchup file is under analysis for understanding the value-added information (upper tropospheric moisture information, temporal and spatial gradients, etc.) from ABI over the background (GFS short-range forecasts).

(5) Finished quantitative analysis on all the ABI test datasets.

(6) Assessed the impact LAP product on local severe storm (LSS) and hurricane forecasts. Information of moisture distribution and transportation in the pre-convection environment is very important for nowcasting and forecasting the severe weather events. An important application of LAP product is to improve the LSS forecasts through assimilation of the high temporal and spatial resolution moisture information into regional and storm scale NWP models. Assimilation techniques and approaches have been developed; the impact on precipitation forecasts for LSS over land from the assimilation of LPWs from AHI shows improvement on heavy precipitation forecasts over that from the assimilation of conventional data. Comparison between AHI IR band radiance assimilation and the TPW/LPW assimilation shows similar impact overall for light rainfall forecasts, with better impact from TPW/LPW for heavy precipitation forecasts over land, partly due to the limited radiance assimilation over land. The approaches for assimilating LPW can be applied to the assimilation of data from ABI once operational.

## **Publications**

Lee, Yong-Keun, Jun Li, Zhenglong Li, and Tim Schmit, 2017: Atmospheric temporal variations in the pre-landfall environment of Typhoon Nangka (2015) observed by the Himawari-8 AHI, *Asia-Pacific Journal of Atmospheric Sciences*. DOI:10.1007/s13143-017-0046-z.

Wang et al. 2018: Impact of moisture information from Advanced Himawari Imager measurements on heavy precipitation forecasts in a regional NWP model, *Journal of Geophysical Research – Atmospheres* (conditionally accepted).

## **4.5 ABI Derived Motion Winds**

**CIMSS Task Leaders: Chris Velden and Steve Wanzong**

**CIMSS Support Scientist: David Stettner**

**NOAA Collaborator: Jaime Daniels (STAR)**

**Budget: \$110,000**

## **NOAA Long Term Goals**

- Weather-Ready Nation



### **NOAA Strategic Goals**

- Serve society's needs for weather and water
- Provide critical support for the NOAA mission

### **CIMSS Research Themes**

- Satellite Meteorology Research and Applications
- Satellite Sensors and Techniques

### **Objective**

To support the testing and optimization of the NESDIS atmospheric motion vector derivation algorithm to operate with GOES-R imagery and provide accurate wind estimates.

### **Project Overview**

The NOAA GOES-R Algorithm Working Group (AWG) winds team lead by STAR and supported by CIMSS is demonstrating derived motion vector (DMV) algorithms and their applications. The software is being tested with GOES-16 imagery, with the resultant DMVs validated against “truth” data sets. The DMV height assignment methodologies continue to be closely integrated with the developments by the AWG Cloud Team ACHA algorithm.

### **Milestones with Summary of Accomplishments and Findings**

#### ***Milestone 1***

The DMV algorithm passed both Beta and Provisional Maturity Reviews. The AWG winds team helped support these reviews by providing DMV validation, case study analyses, and promising applications. CIMSS is assisting STAR in this effort when needed, and team member Wanzong is a key liaison with the Cloud Team.

#### ***Milestone 2***

R&D efforts continue, with a focus by the CIMSS team on the optimization and applications of the DMVs to tropical cyclones and severe weather events. New processing methodologies for events at the smaller scales are being developed and tested.

### **4.6 Hurricane Intensity Estimation (HIE) Algorithm CIMSS Task Leaders: Chris Velden and Tim Olander NOAA Collaborator: Jaime Daniels (STAR) Budget: \$120,000**

#### **NOAA Long Term Goals**

- Weather-Ready Nation

#### **NOAA Strategic Goals**

- Serve society's needs for weather and water
- Provide critical support for the NOAA mission

#### **CIMSS Research Themes**

- Satellite Meteorology Research and Applications
- Satellite Sensors and Techniques

#### **Objective**

Adapt the existing operational Advanced Dvorak Technique algorithm to operate with GOES-R imagery and provide accurate tropical cyclone intensity estimates.



## **Project Overview**

The CIMSS Advanced Dvorak Technique (ADT) was selected to be the operational Hurricane Intensity Estimation (HIE) algorithm to operate within the GOES-R framework. The HIE will provide tropical cyclone (TC) intensity estimates using the GOES-R Advanced Baseline Imager (ABI) infrared imagery. The ADT was selected due to its longstanding use at several operational TC centers worldwide, and because of its proven record for accuracy and reliability in providing objective TC intensity estimates, especially where aircraft reconnaissance is not available. This project will help validate/evaluate the framework HIE TC intensity estimates using GOES-16 data on Atlantic and EPAC TCs.

## **Milestones with Summary of Accomplishments and Findings**

During this reporting period, CIMSS scientists focused on supporting the HIE algorithm Beta Maturity Review, and validating the framework estimates of TC intensity using GOES-16 imagery during a couple of test TC cases in 2017.

### ***Successful HIE Beta Maturity Review***

HIE validation exercises using real GOES-16 data during the checkout mode in 2017 were conducted in coordination with STAR. The case study of Hurricane Irma was selected for evaluation, as it was a long-lived TC that covered multiple intensity ranges. The HIE estimates were compared to the existing ADT estimates, and benchmarked against the NHC Best Track intensities. While the precision of the HIE was not expected to exceed the ADT since polar-orbiting microwave information is not used by the HIE, the results showed an acceptable performance at the Beta Readiness level. It was recommended that several more cases be examined before the Provisional Maturity Review scheduled for sometime this summer.

## **4.7 Volcanic Ash**

**CIMSS Task Leader: Justin Sieglaff**

**NOAA Collaborator: Michael Pavolonis**

**Budget: \$100,000**

### **NOAA Long Term Goals:**

- Weather-Ready Nation

### **NOAA Strategic Goals:**

- Serve society's needs for weather and water
- Support the nation's commerce with information for safe, efficient and environmentally sound transportation
- Provide critical support for the NOAA mission

### **CIMSS Research Themes:**

- Satellite Meteorology Research and Applications
- Satellite Sensors and Techniques

## **Objective**

The GOES-R Volcanic Ash team will ensure the volcanic ash products produced by the GOES-R Ground System meet required specifications.



## Project Overview

We have adopted an infrared-based approach for detecting the presence of ash. This information is supplied to an ash cloud height and mass loading retrieval scheme. In this project we have continued to conduct the cal/val and development work required to assure that we achieve the F&PS specifications for the volcanic ash products. We will perform extensive validation using spaceborne lidar (e.g., CALIPSO) observations of volcanic ash and dust clouds. Any problems discovered in the cal/val process will continue to be addressed. Much of the work will also be aimed at providing GOES-R Ground System (GS) contract support. This work will insure the readiness of the volcanic ash algorithm for operational implementation upon the deployment of GOES-R.

## Milestones with Summary of Accomplishments and Findings

- *Completed beta validation activities*  
Using the developed validation tools, we have successfully completed the beta validation review and the volcanic ash output was declared at beta level readiness during 2017. During the validation analysis, we determined a band swap was necessary for the volcanic ash algorithm to have the best performance. Specifically ABI Band 13 is being used instead of ABI Band 14 in the volcanic ash algorithm.
- *Worked with PRO team to determine ABI Band 13/14 swap was successfully implemented in the ground system*

Using 15 different GOES-16 full-disk scenes from a Popocatepetl Volcano (Mexico) eruption during November 2017, we determined the Ground System output and locally produced output exhibited very good agreement (high correlations and very small mean differences (0.01 km (ash height) and  $-0.09 \text{ g/m}^2$  (ash mass loading), Figure 14). The high correlation and exceedingly small mean differences in the products lead to the conclusion the band swap was correctly implemented in the Ground System.

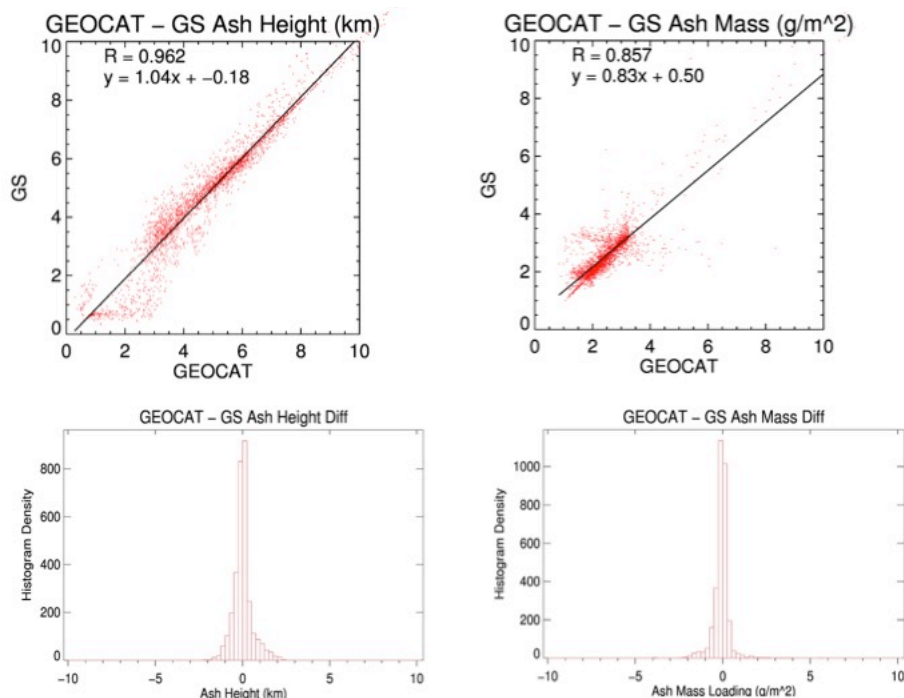

**Figure 14.** Scatter plots (top; ash height left, ash mass loading right) and difference histograms (bottom; ash height left, ash mass loading right) for 15 manually analyzed volcanic ash clouds from the Popocatepetl volcano during November 2017. The two data sources are the GOES-R Ground System and locally run GEOCAT implementations of the GOES-R Volcanic Ash algorithm.



## Publications and Conference Reports

Pavlonis, M. J., A. K. Heidinger, and J. Sieglaff (2013), Automated retrievals of volcanic ash and dust cloud properties from upwelling infrared measurements, *J. Geophys. Res. Atmos.*, 118, doi:[10.1002/jgrd.50173](https://doi.org/10.1002/jgrd.50173).

## References

Pavlonis, M. J., 2010: Advances in extracting cloud composition information from spaceborne infrared radiances: A robust alternative to brightness temperatures. Part I: Theory. *J. Applied Meteorology and Climatology*, **49**, 1992-2012.

## 4.8 Imagery and Visualization

**CIMSS Task Leader: Mathew Gunshor**

**CIMSS Support Scientists: James P Nelson III, Kaba Bah, Joleen Feltz, Hong Zhang**

**NOAA Collaborator: Timothy J. Schmit**

**Budget: \$240,000**

### NOAA Long Term Goals:

- Weather-Ready Nation

### NOAA Strategic Goals:

- Serve society's needs for weather and water
- Support the nation's commerce with information for safe, efficient and environmentally sound transportation
- Provide critical support for the NOAA mission

### CIMSS Research Themes:

- Satellite Meteorology Research and Applications
- Satellite Sensors and Techniques

## Objective

This project's primary objective is to support the GOES-R program in providing Advanced Baseline Imager (ABI) Cloud and Moisture Imagery Product (CMIP) to users.

## Project Overview

The Imagery Team continued to support the GOES-R post launch test/post launch product test efforts, especially concerning the quality of the Cloud and Moisture Imagery Product (CMIP). This included validating the consistency between L1b radiance files and L2 CMIP file outputs; continued support of other GOES-R program efforts to refine ADDE servers for visualization and generation of McIDAS AREA files, both AHI and ABI; supported a study of alternative scan mode scenarios (Mode 6); fine-tuned the validation tools with real ABI data; continued algorithm maintenance; and assisted with provisional maturity product reviews.

## Milestones with Summary of Accomplishments and Findings

### **Accomplishments for the Imagery and Visualization team this year:**

- Intensive Post-launch validation of the GOES-R CMI product.
  - Includes validating the consistency between L1b radiance and L2 CMIP files.





- Passed provisional PS-PVR CMIP review.
- Upgraded product validation tools to meet needs under operational stream of data.
- Continued development of techniques for RGB and “natural true color imagery” for application to ABI.
  - “CIMSS Natural True Color” algorithm is in AWIPS for National Weather Service (NWS) forecasters and available for McIDAS-X for McIDAS users.
  - “CIMSS Natural True Color” imagery is available in real time on the SSEC web site and in the RealEarth web app and smart phone apps for iOS and Android.
- Continued generation of case-study imagery for training team, social media content, and GOES-R program presentations.
- “Great American Eclipse of 2017” media event supported August 2017 with images and animations.
- 2017 Hurricane Season imagery animations made for social media outreach.
- CONUS sector location maps generated for East, West, and Test locations for use in training on sector coverage.
- Paper submitted to Journal of Operational Meteorology (National Weather Association).
- Paper published in BAMS.
- Supported GOES-16 transition to GOES-East
  - December 18, 2017 GOES-16 became operational GOES-East at 75.2W

### Milestones

- Jun 2017: PS-PVR Provisional CMIP Review

The proposed Nov 2017 milestone: “PS-PVR Full-maturity CMIP Review” was not met because full-maturity status review was moved by the GOES-R program to June 2018.

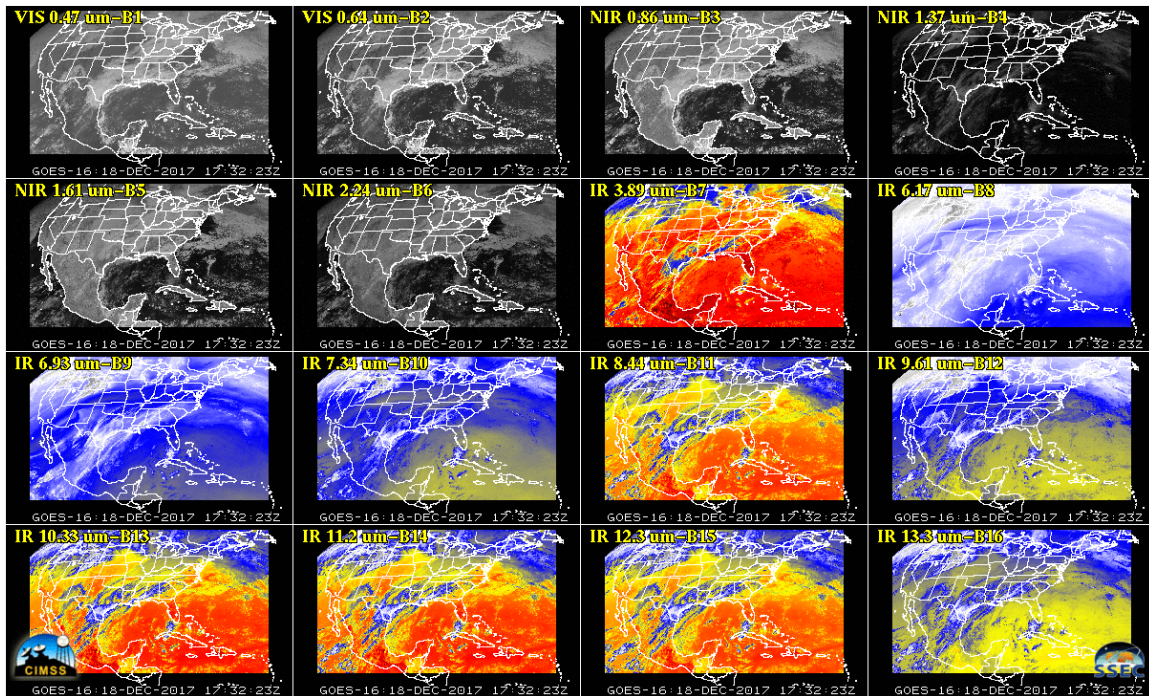

Figure 15. First GOES-16 ABI 16-panel image of all bands after GOES-16 became operational GOES-East on December 18, 2017 at 17:30 UTC.



## **Publications and Conference Reports**

Poster Presented at AMS 2018 Annual Meeting.

Schmit, Timothy J.; Griffith, Paul; Gunshor, Mathew M.; Daniels, Jaime M.; Goodman, Steven J. and Lebar, William J. A closer look at the ABI on the GOES-R series. Bulletin of the American Meteorological Society, Volume 98, Issue 4, 2017, pp.681-698.

### **4.9 Estimate of Fractional Snow Cover with ABI**

**CIMSS Task Leader: Yinghui Liu**

**NOAA Collaborator: Jeffrey Key**

**Budget: \$140,000**

#### **NOAA Long Term Goals**

- Climate Adaptation and Mitigation
- Weather-Ready Nation

#### **NOAA Strategic Goals:**

- Serve society's needs for weather and water
- Understand climate variability and change to enhance society's ability to plan and respond
- Provide critical support for the NOAA mission

#### **CIMSS Research Themes:**

- Satellite Meteorology Research and Applications

#### **Objective**

To test, implement, and document the fractional snow cover (FSC) algorithm for the GOES-R Advanced Baseline Imager (ABI). This product provides the sub-pixel area covered by snow. The primary users of the snow cover product are the National Ice Center (NIC), NCEP, and NWS forecasters.

#### **Project Overview**

CIMSS has played the leading role in developing ice products for ABI. The snow cover algorithm was developed by members of the AWG Cryosphere Team at the NWS National Operational Hydrologic Remote Sensing Center (NOHRSC) and the University of Utah (Tom Painter, now UCLA/JPL) (Dozier et al. 2009, Painter et al. 2009). For long-term maintenance of the algorithm it is decided that CIMSS and the NOAA Advanced Satellite Products Branch (ASPB) will take ownership of the software and documentation to ensure long-term viability as a NESDIS operational product.

Previous work has been focused on becoming familiar with the Fractional Snow Cover software package, documentation, and its test data. The software has been compiled, tested, and implemented at CIMSS. Running the software on the test data showed and gave the same results as provided by GOES-R AWG AIT. The GOESRSCAG (GOES-R Snow Cover And Grain Size) algorithm has been implemented to generate near real-time FSC daily over the North America, with inputs of MODIS surface reflectance and other products as a proxy of GOES-R.

With the GOES-16 FSC becoming available last year, we have started to calibrate/validate GOES-16 FSC against FSC from other snow products. The results will be shown in the next



section. We will continue with algorithm validation, which is largely an effort to expand the scope of validation to a broader range of geographic areas and conditions. Independent estimates of fractional snow cover retrieved from higher resolution imaging systems (e.g., LANDSAT) under a variety of conditions will also be used to evaluate the accuracy of the product.

### **Milestones and Summary of Accomplishments and Findings**

The Team has developed an automated validation system for GOES-16 FSC. This tool routinely acquires snow cover products from different sources, including the National Ice Center's Center's Interactive Multisensor Snow and Ice Mapping System (IMS) Northern Hemisphere snow cover at 1 km, and snow cover derived from the NOAA National Weather Service's National Operational Hydrologic Remote Sensing Center (NOHRSC) SNOw Data Assimilation System (SNODAS) at 1 km over the Continental United States (CONUS) and southern Canada. All data are then remapped to the GOES-16 footprint. IMS and SNODAS FSC at each GOES-16 footprint are calculated as the ratio of snow covered pixels to all pixels. The automated system then plots all FSC products that were acquired and performs simple statistical comparisons with GOES-16 FSC.

The tool will be expanded to include other snow cover products, e.g. Landsat-8, and more robust statistical comparisons. Figure 16 shows qualitatively that GOES-16 provides sub-pixel snow cover information much better than IMS when compared to the MODIS false color image, while IMS shows better information on snow extent due to no cloud contamination in the IMS.

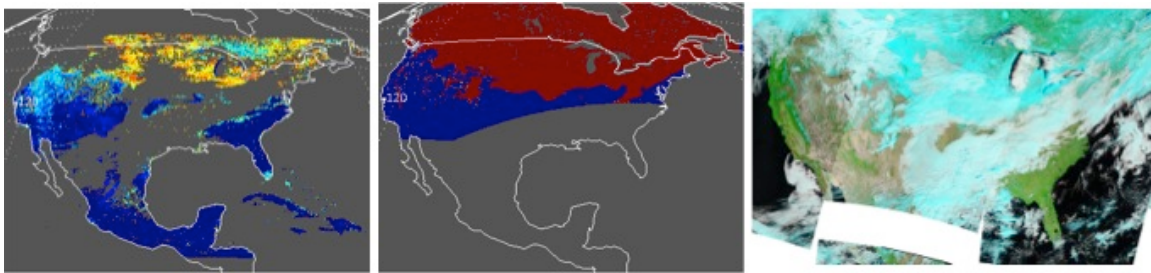

**Figure 16. GOES-16 Fractional Snow Cover daily composite on February 6, 2017 with quality control (left), from IMS (middle), and MODIS false color image (right).**

We have implemented two approaches to screen the cloud. The first is based on all quality flags imbedded in the GOES-16 FSC product, and the second uses the GOES-16 cloud mask and all GOES-16 FSC quality flags except cloud mask flag. Figure 17 shows both approaches give the same results. We suggest using the GOES-R 16 FSC quality flags to screen cloud and to remove other low quality retrievals. There is another potential approach to use snow grain size retrieval to screen cloud. Clouds are best addressed are high-flying, small-particle snow. Because the particle size is small, snow grain size retrieval less than a threshold of 50 microns is flagged as cloud. We will test this approach.

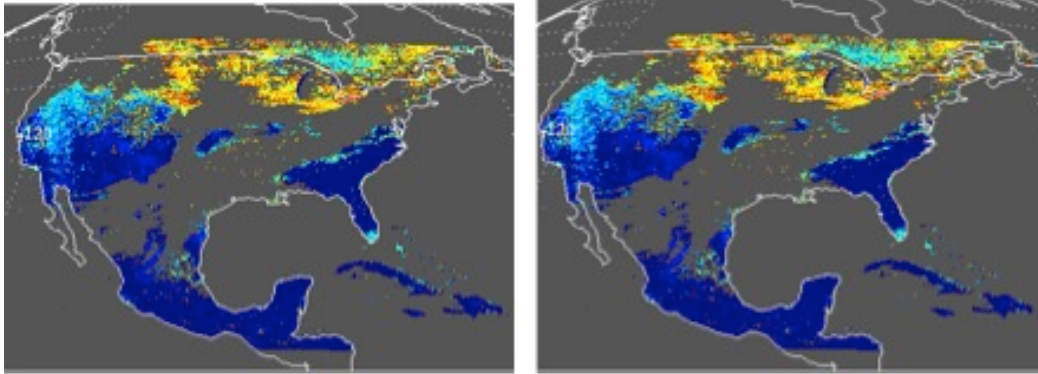

Figure 17. GOES-16 Fractional Snow Cover daily composite on February 6, 2017 with all quality control within FSC product (left), and with GOES-16 cloud mask and all other FSC quality control without cloud mask quality flag (right).

### References

Dozier, J., R. O. Green, A. W. Nolin, and T. H. Painter (2009), Interpretation of snow properties from imaging spectrometry, *Remote Sensing of Environment*, doi: 10.1016/j.rse.2007.07.029.

Thomas H. Painter, Karl Rittger, Ceretha McKenzie, Peter Slaughter, Robert E. Davis, Jeff Dozier, 2009, Retrieval of subpixel snow covered area, grain size, and albedo from MODIS, *Remote Sensing of Environment*, 113, 868-879, 2009.

### 4.10 GOES-R Support for International TOVS Study Conference ITSC-21

**CIMSS Task Leader: Allen Huang**

**NOAA Collaborator: Mitch Goldberg**

**Budget: \$4,000**

#### NOAA Long Term Goals:

- Weather-Ready Nation

#### NOAA Strategic Goals:

- Serve society's needs for weather and water
- Provide critical support for the NOAA mission

#### Cross-Cutting Priorities

- Integrating global environmental observations and data management
- Ensuring sound, state-of-the-art research
- Developing, valuing and sustaining a world-class workforce

#### CIMSS Research Themes:

- Education and Outreach

### Objective

The objective of this was to provide partial support for the ITSC-21 Conference to be held in Darmstadt, Germany in 29 November to 5 December 2018. The funding supported the conference organization efforts at CIMSS and also support the publication of the Working Group Report and an update to the ITWG Web pages regarding conference activities.



## Project Overview

The International TOVS Working Group (ITWG) is convened as a sub-group of the International Radiation Commission (IRC) of the International Association of Meteorology and Atmospheric Physics (IAMAP). The ITWG organizes International TOVS Study Conferences which have met approximately every 18 months since 1983.

Through the ITWG forum operational and research users of TOVS/ATOVS/AIRS/IASI and other atmospheric sounding data have exchanged information on data processing methods, derived products, and the impacts of radiances and inferred atmospheric temperature and moisture fields on numerical weather prediction, and weather and climate studies.

## Milestones with Summary of Accomplishments and Findings

The most recent conference, the Twenty first International TOVS Study Conference (ITSC-21) was held in Darmstadt, Germany in November 2018. Hosted by EUMETSAT and co-organized by NOAA, ECMWF, DWD and SSEC, the conference includes oral and poster presentations, and the formation of working sub-groups to discuss issues and provide actions and recommendations to share with the international community. The conference covered a wide range of topics concerning atmospheric sounding, its applications and related issues including:

- Evaluation of new polar microwave and infrared sounding data, such as from the JPSS-1, FY3D, or Meteor-M N2-1 satellites;
- Evaluation of and preparation for sounding capabilities from geostationary orbit (e.g., FY4A, MTG-IRS);
- Updates on operational processing and the exploitation of ATOVS, ATMS, SSMIS and hyperspectral sounder data (AIRS, IASI, CrIS);
- New applications of microwave and infrared sounder data in numerical weather prediction and nowcasting (e.g., new assimilation techniques, bias tuning, use of cloudy radiances), including blended products from polar orbiting and geostationary satellites;
- Use of microwave and infrared sounder data over land and ice surfaces;
- Generation of geophysical parameters from or for microwave or infrared sounding data;
- Applications of microwave and infrared sounder data in climate monitoring and GCOS activities;
- Direct readout software and retransmission services;
- Radiative transfer model development and validation, especially of fast radiative transfer models;
- Studies and results for future infrared and microwave sounders;
- Updates on Satellite Programs and International Coordination (WMO, CGMS); and
- Other relevant issues include the validation and tuning of surface models, satellite sounding requirements for GEOSS, and absolute calibration and cross-calibration of the global satellite observing system

There are also technical sub-groups which meet informally to co-ordinate ATOVS, EOS, S-NPP, NOAA, METOP, FY-3, and AHI direct broadcast processing software, radiative transfer models and frequency protection issues relevant to the ITWG community.

The conference Working Group Report summarizes the recommendations and actions of these working groups. Technical Proceedings of the scientific presentations and posters are also published. The ITWG web site (<http://cimss.ssec.wisc.edu/itwg/>) contains electronic versions of the conference papers, presentations and posters. Together, these documents and web pages reflect the conduct of highly successful international meetings.



This funding provided partial resource to conduct the 21<sup>th</sup> ITSC in Darmstadt, Germany, on 29 November - 5 December 2018. The agenda and presentations from this meeting is located at:

<https://cimss.ssec.wisc.edu/itwg/itsc/itsc21/program/>

Over 12 out of ~180 participants was financially supported that attended the Conference from 36 organizations, providing a wide range of scientific contributions. Sixteen countries and three international organizations were represented: Brazil, Canada, China, France, Germany, India, Japan, Norway, Russia, South Korea, Sweden, Switzerland, United Kingdom, United States, ECMWF, EUMETSAT, and the WMO. The Working Groups had very productive discussions and it was again encouraging to see a large number of new, younger scientists participating. The trade mark of this meeting, the working group joint and independent meetings were held that cover the topics of 1) NWP, 2) Radiative transfer and surface properties, 3) Climate, 4) Advanced sounder, 5) Products and software, and 6) International and future systems. Two technical sub-group reports were also given (<https://cimss.ssec.wisc.edu/itwg/itsc/itsc21/program/index.html>). Next ITWG co-chair election were also held after the meeting casted by e-mail where two candidates out of 7 nominations were elected to be the new co-chairs for ITSC-22 to ITSC-24. The newly selected co-chairs are Liam Gumley of SSEC/UW-Madison, and Vincent Guidard of Meteo France.

## **5. CIMSS Support to GOES-R NOAT Priority Research Risk Reduction**

### **5.1 GOES-R Future Capability: SO<sub>2</sub> Detection**

**CIMSS Task Leader: John Cintineo**

**CIMSS Support Scientist: Justin Sieglaff**

**NOAA Collaborator: Michael Pavolonis**

**Budget: \$72,000**

#### **NOAA Long Term Goals:**

- Climate Adaptation and Mitigation
- Weather-Ready Nation

#### **NOAA Strategic Goals:**

- Serve society's needs for weather and water
- Understand climate variability and change to enhance society's ability to plan and respond
- Provide critical support for the NOAA mission

#### **CIMSS Research Themes:**

- Satellite Meteorology Research and Applications
- Satellite Sensors and Techniques

#### **Objective**

To detect SO<sub>2</sub> from geostationary satellites for weather and climate applications.

#### **Project Overview**

Timely detection of SO<sub>2</sub> is important to aviation and, as such, SO<sub>2</sub> detection (and volcanic ash detection) is a priority of the National Weather Service. The GOES-R ABI will have the unique capability to detect and characterize SO<sub>2</sub> clouds from a geostationary orbit. The GOES-R



Algorithm Working Group (AWG) developed an ABI SO<sub>2</sub> detection algorithm to take advantage of this capability (Pavolonis and Parker, 2010). The SO<sub>2</sub> detection algorithm utilized infrared channels that are sensitive to SO<sub>2</sub> absorption, specifically the 7.3 and 8.5  $\mu\text{m}$  channels. These spectral channels, combined with the 11 and 12  $\mu\text{m}$  channels, were used to distinguish SO<sub>2</sub> clouds from all other features. At the 80% code delivery, the GOES-R AWG SO<sub>2</sub> algorithm was very close to meeting the performance specification of 70% correct detection for SO<sub>2</sub> concentrations 10 Dobson Units or greater (actual correct detection accuracy was 64%). Significant progress was made under the GOES-R AWG project, yet further algorithm development and refinement is needed to ensure that the full capabilities of the ABI are being leveraged for SO<sub>2</sub> monitoring. Developing the GOES-R SO<sub>2</sub> capabilities to full maturity and integrating satellite-derived SO<sub>2</sub> information from GOES-R with relevant low earth orbit satellites are the goals of this project.

### **Milestones with Summary of Accomplishments and Findings**

The SO<sub>2</sub> detection capabilities developed under this project were integrated into the VOLcanic Cloud Analysis Toolkit (VOLCAT) automated alerting tool. The automated alerting tool utilizes cloud object properties to identify volcanic cloud features (e.g. Pavolonis et al., 2015a; Pavolonis et al., 2015b) and generate an alert for operational decision makers.

The VOLCAT plume-fitting algorithm, originally developed for volcanic ash clouds, was adapted for automatically identifying volcanic SO<sub>2</sub> plumes captured by the ABI. The plume-fitting algorithm has many tunable parameters that will continue to be refined. However, ABI data can now be used to generate SO<sub>2</sub> alerts within VOLCAT. An example SO<sub>2</sub> alert is shown in Figure 18 (next page).

GOES-R based SO<sub>2</sub> alerts will be distributed to the Anchorage and Washington Volcanic Ash Advisory Centers and the USGS for evaluation after a 2-3 month internal test period.

The VOLCAT website was updated to allow for future distribution of GOES-R based SO<sub>2</sub> alerts to users.

The quality of the alerts will improve as progress is made on optimizing performance for the ABI and integrating with low earth orbit satellites, such as the JPSS series.

### **Publications and Conference Reports**

Australian Bureau of Meteorology's Annual Research Workshop, November 26 – December 6, 2017 (Melbourne, Australia); Presentation entitled: "Transforming Satellite Data to Products in the era of Big Data."



CIMSS Cooperative Agreement Report  
1 April 2017 – 31 March 2018

\*\*\*\*\* AT&T 10:41 AM 1 (410) 200-883

Text Message Today 10:39 AM

FRM:volcano.alerts-noreply@ssec.wisc.edu  
SUBJ:NOAA/CIMSS VOLCAT Alert  
MSG:  
1 SO2 ALERT(S)

Tap to Load Preview

volcano-test.sse... >

volcano.alerts-noreply@ssec.wisc.edu  
To: MICHAEL PAVOLONIS  
NOAA/CIMSS VOLCAT Alert

@\*\*\*\*\*VOLCANIC ALERTS\*\*\*\*\*  
STARTING DATE/TIME OF IMAGE: 2017-09-04 20:00:30 [UTC]  
PRODUCTION DATE/TIME OF ALERT: 2018-03-01 16:48:54 [UTC]  
PRIMARY INSTRUMENT: GOES-16 ABI  
WMO SPACECRAFT ID: 152  
LOCATION/ORBIT: GEO  
L1 FILE: OR\_ABI-L1b-RadF-MSC16\_G16\_s20172472000345\_e2017:  
VOLCANO DATABASE: data/common/volcat-ancillary/alerts/Volcat\_  
NUMBER OF ASH CLOUD ALERTS: 0  
NUMBER OF VOLCANIC CO ALERTS: 0  
NUMBER OF VOLCANIC THERMAL ANOMALY ALERTS: 0  
NUMBER OF SO2 CLOUD ALERTS: 1

REPORT WITH IMAGES:  
<https://volcano-test.ssec.wisc.edu/alert/report/84887>

-----  
POSSIBLE SO2 CLOUD FOUND  
Alert Status: New Volcanic Feature  
Alert Confidence: HIGH  
Identification Method: Basic Spectral  
Latitude of Radiative Center: -0.41 (degrees)  
Longitude of Radiative Center: -91.58 (degrees)  
Mean Object Date/Time: 1989-12-31 23:43:21 [UTC]  
Mean Viewing Angle: 3.0 (degrees)  
Mean Solar Zenith Angle: 29.4 (degrees)  
Nearby Volcanoes (meeting alert criteria):  
Fernandina(5.4 km)  
Darwin(41.9 km)  
Ecuador(43.3 km)  
Alcedo(51.3 km)  
Wolf(54.1 km)  
Median Probability of Pixels: 99.33 [%]  
Mean Tropopause Height [AMSL]: 16441.6 [km] (53944956 [ft])  
Total Area: 1186.5 [km^2]

Country/Countries: Ecuador  
Volcanic Region(s): South America  
Volcanic Subregion(s): Galapagos Islands  
VAG Region(s) of Nearby Volcanoes: Washington  
FIR Region(s) of Nearby Volcanoes: Unknown

**Volcanic Cloud Alert Report**

Date: 2017-09-04  
Time: 20:00:30  
Production Date and Time: 2018-03-01 16:48:54 UTC  
Primary Instrument: GOES-16 ABI

More details ▾

**Possible Sulfur Dioxide Cloud**

Possible Sulfur Dioxide Cloud		Basic Information

Show More ▲ View all event imagery x

Figure 18. An example GOES-16 ABI based VOLCAT SO<sub>2</sub> alert is shown. The alert captures an SO<sub>2</sub> emission from the Fernandina volcano in the Galapagos Islands on September 4, 2017 at 20 UTC. When GOES-16 measurements are used to detect a new volcanic SO<sub>2</sub> emission, VOLCAT generates SMS (text message) and email alerts (top images) that contain a hyperlink to an online alert report (bottom images).

## References

Pavolonis, M.J. and A. Parker, 2010: GOES-R Advanced Baseline Imager (ABI) Algorithm Theoretical Basis Document for SO<sub>2</sub> Detection, [http://www.goes-r.gov/products/ATBDs/option2/Aviation\\_SO2\\_v1.0\\_no\\_color.pdf](http://www.goes-r.gov/products/ATBDs/option2/Aviation_SO2_v1.0_no_color.pdf).

Pavolonis, M. J., 2010: Advances in Extracting Cloud Composition Information from Spaceborne Infrared Radiances-A Robust Alternative to Brightness Temperatures. Part I: Theory. *Journal of Applied Meteorology and Climatology*, **49**, doi:10.1175/2010JAMC2433.1.

Pavolonis, M. J., J. Sieglaff, and J. Cintineo (2015a), Spectrally Enhanced Cloud Objects (SECO): A Generalized Framework for Automated Detection of Volcanic Ash and Dust Clouds using Passive Satellite Measurements, Part I: Multispectral Analysis, *J. Geophys. Res. Atmos.*, **120**, doi:10.1002/2014JD022968.

Pavolonis, M. J., J. Sieglaff, and J. Cintineo (2015b), Spectrally Enhanced Cloud Objects (SECO): A Generalized Framework for Automated Detection of Volcanic Ash and Dust Clouds using Passive Satellite Measurements, Part II: Cloud Object Analysis and Global Application, *J. Geophys. Res. Atmos.*, **120**, doi:10.1002/2014JD022969.





## **5.2 GOES-R Future Capability: Continued Development of the GOES-R AWG Fog/Low Cloud Products**

**CIMSS Task Leader: Corey Calvert**

**CIMSS Support Scientists: Scott Lindstrom, Amanda Terborg and Chad Gravelle**

**NOAA Collaborators: Michael Pavolonis**

**Budget: \$72,000**

### **NOAA Long Term Goals:**

- Weather-Ready Nation

### **NOAA Strategic Goals:**

- Serve society's needs for weather and water
- Support the nation's commerce with information for safe, efficient and environmentally sound transportation
- Provide critical support for the NOAA mission

### **CIMSS Research Themes:**

- Satellite Meteorology Research and Applications
- Satellite Sensors and Techniques

### **Objective**

We are developing the next generation fog/low cloud detection algorithm that improves upon heritage methods by fusing satellite, numerical weather prediction model and other ancillary data sets to produce a probability that various hazardous low cloud conditions are present.

### **Project Overview**

Low ceiling and visibility is a weather hazard that nearly every forecaster, in nearly every National Weather Service (NWS) Weather Forecast Office (WFO), must regularly address. As such, reliable methods for detecting and characterizing hazardous low clouds are needed. Traditionally, hazardous areas of Fog/Low Stratus (FLS) are identified using a simple stand-alone satellite product that is constructed by subtracting the 3.9 and 11  $\mu\text{m}$  brightness temperatures. However, the 3.9-11  $\mu\text{m}$  brightness temperature difference (BTD) has several major limitations. In an effort to address the limitations of the 3.9-11  $\mu\text{m}$  BTD, the GOES-R Algorithm Working Group (AWG) developed an approach that fuses satellite, Numerical Weather Prediction (NWP) model, Sea Surface Temperature (SST) analyses, and other data sets (e.g. digital surface elevation maps, surface emissivity maps, and surface type maps) using a naïve Bayes classifier to determine the probability that Marginal Visual Flight Rules (MVFR), Instrument Flight Rules (IFR), and Low Instrument Flight Rules (LIFR) conditions are present at the resolution of the satellite data. MVFR/IFR/LIFR conditions are characterized by a cloud ceiling below 3000/1000/500 ft and/or a surface visibility less than 5/3/1 mile(s) respectively. The GOES-R fog/low cloud algorithm is an enterprise system in that it can use satellite data from a variety of current data sensors (GOES, MTSAT, MODIS, AVHRR, VIIRS, SEVIRI, AHI and ABI) and future operational sensors and NWP data from a variety of models (GFS, RUC and RAP). Validation efforts, using surface observations over CONUS from each month of the year, indicate that the GOES-R IFR probability product is nearly twice as skillful as the traditional 3.9-11  $\mu\text{m}$  BTD product at identifying IFR conditions, while also providing additional probabilities about whether the cloud meets MVFR or LIFR criteria. The GOES-R approach incorporates the information given by the 3.9-11  $\mu\text{m}$  BTD, so the traditional BTD product never significantly outperforms it. Further, unlike the traditional product, the GOES-R probabilities have the same



interpretation day and night. Thus, the GOES-R probability products should be thought of as an upgrade to the traditional product, not a complement or supplement. Finally, in addition to the probability products, the GOES-R FLS algorithm also produces an estimation of the fog/low stratus thickness (cloud top height minus cloud base height). The GOES-R FLS thickness product can be used to infer dissipation time for single cloud layer radiation fog events.

The GOES-R FLS probability and thickness products are available in NAWIPS/AWIPS2 and are routinely utilized by nearly every National Weather Service (NWS) Weather Forecast Office (WFO) and National Center. While the “GOES-R” FLS products improve upon the traditional FLS detection approach, the algorithm is still being optimized for the far more advanced GOES-R series measurement capabilities. The FLS algorithm was developed about 5 years prior to the launch of GOES-16 using GOES-NOP series data. Now that a sufficient amount of on-orbit GOES-16 data is available, the FLS algorithm can be further optimized for use with GOES-R series data. The goal of this project is to extend the capabilities of the FLS products through full utilization of GOES-R capabilities for future operational implementation with on-orbit GOES-R series data.

### **Milestones with Summary of Accomplishments and Findings**

- In order to optimize the performance of the GOES-R FLS algorithm for GOES-R series measurements, conditional probability relationships must be derived from a large, diverse sampling of on-orbit GOES-16 data matched in space and time with surface observations of ceiling and visibility. The GOES-R conditional probability relationships have been derived from 8 weeks of on-orbit GOES-16 data (1 week from each month between March and October 2017). An additional 4 weeks of on-orbit GOES-16 data (1 week from November, 2017 - February, 2018) are currently being processed and will be added to the training so the entire annual cycle is accounted for.
- The performance of the GOES-R specific conditional probability relationships was assessed using independent GOES-16 data. The independent validation analysis indicates that the GOES-16 FLS products are more accurate and better calibrated than the GOES-13 version. The increase in accuracy can largely be attributed to the improved spatial resolution of GOES-16, although the enhanced spectral and temporal measurement capabilities also help improve performance. Figure 19 shows the attributes diagrams created for the GOES-13 and GOES-16 IFR probability products. These diagrams illustrate the improved calibration of the GOES-R version of the FLS products compared to the GOES-NOP version.
- Transitioning the FLS products to operations is critical for ensuring that users have sustained access to the FLS products, which are considered a high priority by NWS users. Prior to the operational implementation (scheduled for the summer of 2018), the GOES-16 FLS products are being distributed to users via an experimental feed. Before distribution, the GOES-16 FLS products must be converted into compatible data formats so they can be properly viewed in both NAWIPS (national centers) and AWIPS2 (NWS). Tools were developed to convert the data into AREA files required by NAWIPS and SCMI-compatible netCDF files required by AWIPS2. The SCMI-compatible netCDF files incorporate a tiling capability allowing users the option to download geographic subsets of the products over their areas of interest. This feature reduces the amount of required bandwidth when retrieving the products. Configuration information for NAWIPS/AWIPS2 was also created to ensure users organize and view the FLS products as the developers intend. Figure 20 shows the GOES-16 FLS products viewed in NAWIPS and AWIPS2.



- The near real-time GOES-16 FLS products were added to a diagnostic website (<http://cimss.ssec.wisc.edu/geocat/>) where they can be evaluated using a smart phone or Internet browser.
- Many new examples have been added to the GOES-R FLS Blog (“the fog blog”) to serve as a training resource.
- The AWC, AAWU, and most NWS WFOs are utilizing the GOES-NOP version (GOES-15), and now the GOES-R version (GOES-16) of the FLS products in daily operations.
- The GOES-R ABI has many more spectral channels than the GOES-NOP imagers. Some of these additional spectral channels are useful for improving the detection and characterization of fog/low stratus (FLS). Our research has found that the 8.5  $\mu\text{m}$  channel (ABI band 11), in particular, is very useful for improving the detection of FLS at all times of the day. More specifically, we found that the difference between the observed 8.5-11  $\mu\text{m}$  brightness temperature difference (BTD) and the estimated clear sky 8.5-11  $\mu\text{m}$  BTD is skillful for classifying low clouds into flight rule categories. The observed minus clear sky 8.5-11  $\mu\text{m}$  BTD difference metric, known as the 8.5-11  $\mu\text{m}$  BTD bias, has been successfully integrated into the GOES-R FLS algorithm and research is ongoing to fine-tune how it is best used.
- Previous GOES-16 FLS validation efforts focused on using large amounts of re-processed data (one day per month) accounting for seasonal differences. We are currently developing tools to automatically validate the FLS products in real time. This will allow us to track the quality of the FLS products and increase the flexibility of our validation capabilities in the future.

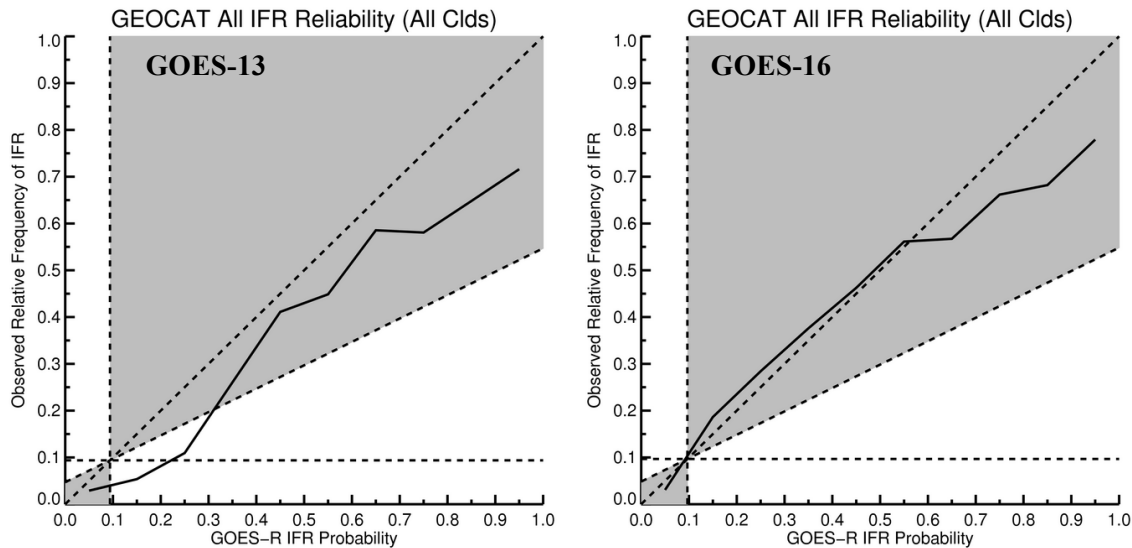

**Figure 19. Attributes diagrams for the GOES-13 (left) and GOES-16 (right) IFR probability products created using 8 days (1 day from each month of March-October 2017) co-located with surface observations of cloud ceiling and surface visibility. Pixels with all solar orientations and cloud types were used to create these diagrams. The diagonal, dashed line bisecting the diagram represents perfect calibration. The diagram for the GOES-16 IFR probability product is noticeably closer to the dashed line confirming that it is more accurately calibrated than the GOES-13 IFR probability product. Similar improvements were seen with the LIFR and MVFR probability products.**

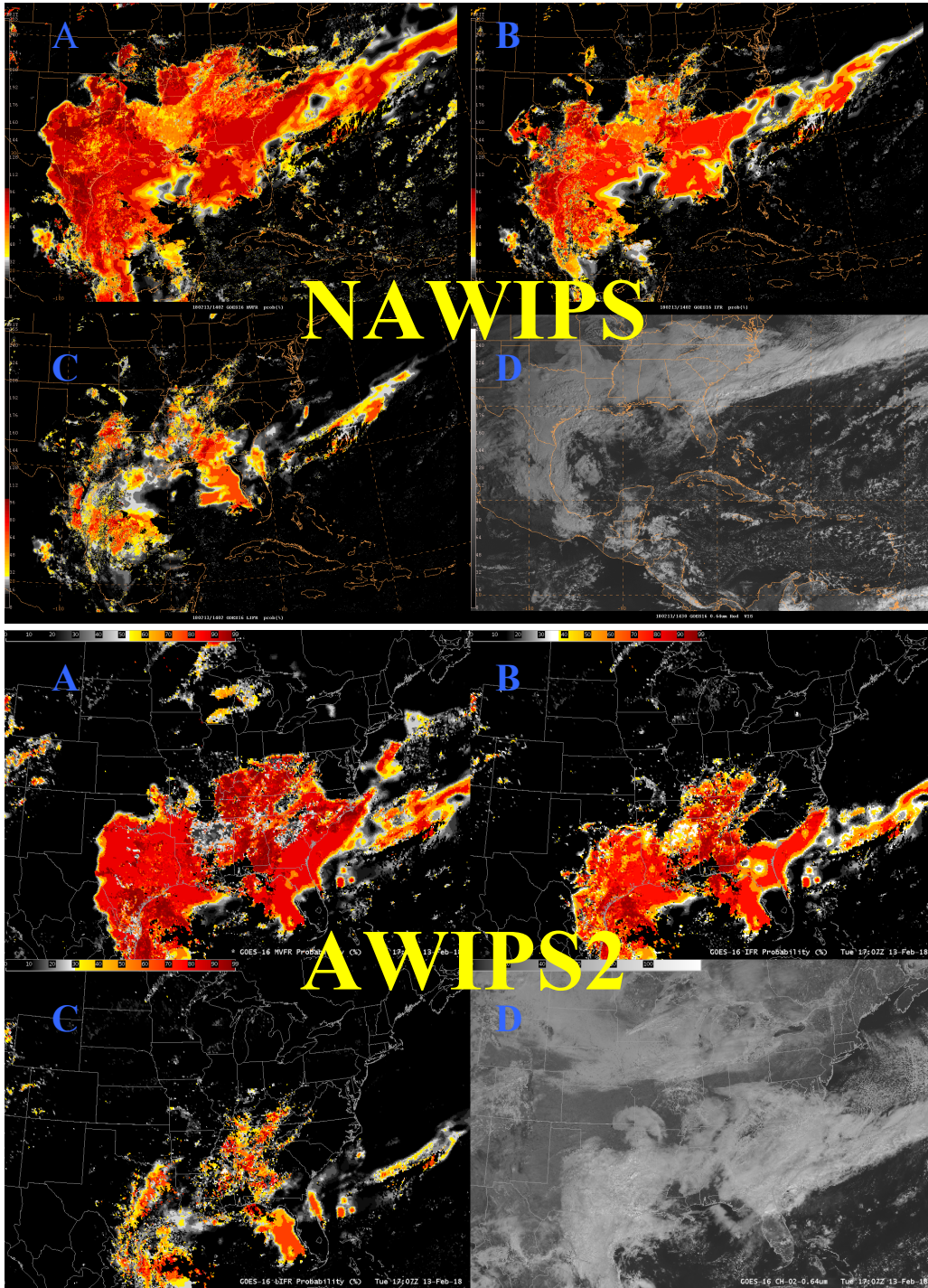

Figure 20. The GOES-16 FLS products are now available in near real-time for NAWIPS (top 4 images) and AWIPS2 (bottom 4 images) via an experimental feed. The MVFR (A), IFR (B) and LIFR (C) probability products, along with a visible satellite image (D), are shown above. Configuration information for both NAWIPS and AWIPS2 is provided to ensure the FLS products are properly named, organized and viewed using preferred color tables.



## **Publications and Conference Reports**

Pavolonis, M.J. and C. G., Calvert, 2018: Probabilistic Identification of Hazardous Fog and Low Stratus Clouds Using Satellite and Numerical Weather Prediction Data, *J. Appl. Meteor. and Climatology*, To be submitted.

## **5.3 Evaluation of Turbulence-Detection Methods on Himawari-8**

**CIMSS Task Leader: Anthony Wimmers**

**CIMSS Support Scientists: Sarah Griffin, Jordan Gerth**

**NOAA Collaborators: Bill Ward (Honolulu NWS), Amanda Terborg (Aviation Weather Center)**

**Budget: \$96,000**

### **NOAA Long Term Goals:**

- Weather-Ready Nation

### **NOAA Strategic Goals:**

- Serve society's needs for weather and water
- Support the nation's commerce with information for safe, efficient and environmentally sound transportation
- Provide critical support for the NOAA mission

### **CIMSS Research Themes:**

- Satellite Meteorology Research and Applications
- Satellite Sensors and Techniques

## **Objective**

The creation of new, real-time turbulence viewing tools for Himawari-8 and GOES-16 (online and through AWIPS) and their ongoing refinement based on feedback from NOAA aviation hazard forecasters.

## **Project Overview**

Stakeholders in the Pacific Region have stated the need for products that provide warning for atmospheric conditions leading to aircraft turbulence, and these are underrepresented in the GOES-R generation ABI product stream. We have previously tested various products on Himawari-8 and found one product, the High-Pass filter gravity wave detection, to be especially effective. We have investigated the physical reasons behind this product's effectiveness; produced the product in real-time for Himawari-8, GOES-16 and Meteosat-10; and collaborated with forecasters to find the best methods for real-time usage.

## **Milestones with Summary of Accomplishments and Findings**

### ***Online Presentation of Real-time Products and Aircraft Reports***

Sarah Griffin has reworked a previous satellite imagery viewer to display the gravity wave product in real-time with simultaneous automated aircraft observations (Figure 21). The software also sends out automated alerts when high turbulence observations are displayed. This setup has enabled the researchers and forecasters to collaborate to analyse the high-pass signatures of major turbulent events, and has confirmed that the subset of gravity waves that are associated with turbulence, and not nearby convection, are usually closely associated with signatures of directional shearing.

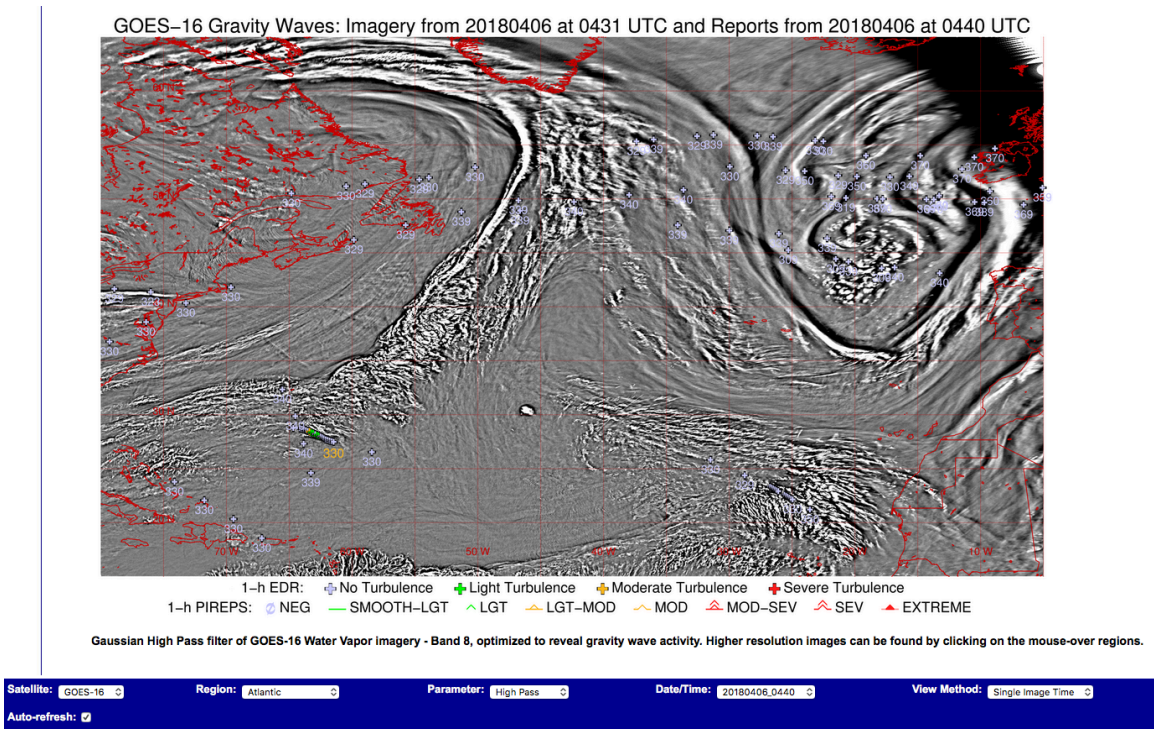

Figure 21. Screen capture of the gravity wave product turbulence online viewer, showing the North Atlantic from GOES-16.

### ***AWIPS Rendering of High-pass Gravity Wave Product***

Jordan Gerth adapted the high-pass gravity wave product to run as an image filter function in AWIPS2, and this is now a regular visualization tool for the Honolulu WFO (Figure 22). An added benefit to this tool is that it can be viewed semi-transparently with the original water vapor channel in order to appear with the familiar colors and contrasts, but still provide extra highlighting of any gravity wave feature.

### ***Publication of High-pass Gravity Wave Paper***

In 2017 we submitted a paper to Weather and Forecasting (published in January 2018) introducing the high-pass gravity wave product and discussing related nowcasting/forecasting strategies (Wimmers et al., 2018). The paper also presented a new, practical discovery with the AHI/ABI instruments, which is that their temperature resolution exceeds (and sometimes far exceeds) the data resolution of the 8-bit renderings often distributed for operational visualization. We offer a possible solution that high-pass filtering can create products that are well-displayed in 8-bit resolution and capture all the sub-1K gradients that are important for gravity wave visualization.

### ***Collaboration with Forecasters for Developing Interpretation and Visualization Techniques***

In December 2017 Anthony Wimmers and Jordan Gerth visited the Honolulu WFO to present research, shadow forecasters and brainstorm new interpretation methods for the gravity wave product. We found that the gravity wave product filled an important niche in defining the area for turbulent SIGMETs. Also, while shadowing forecasters we saw the need for future enhancements to automate the products and generate high-accuracy forecaster alerts.

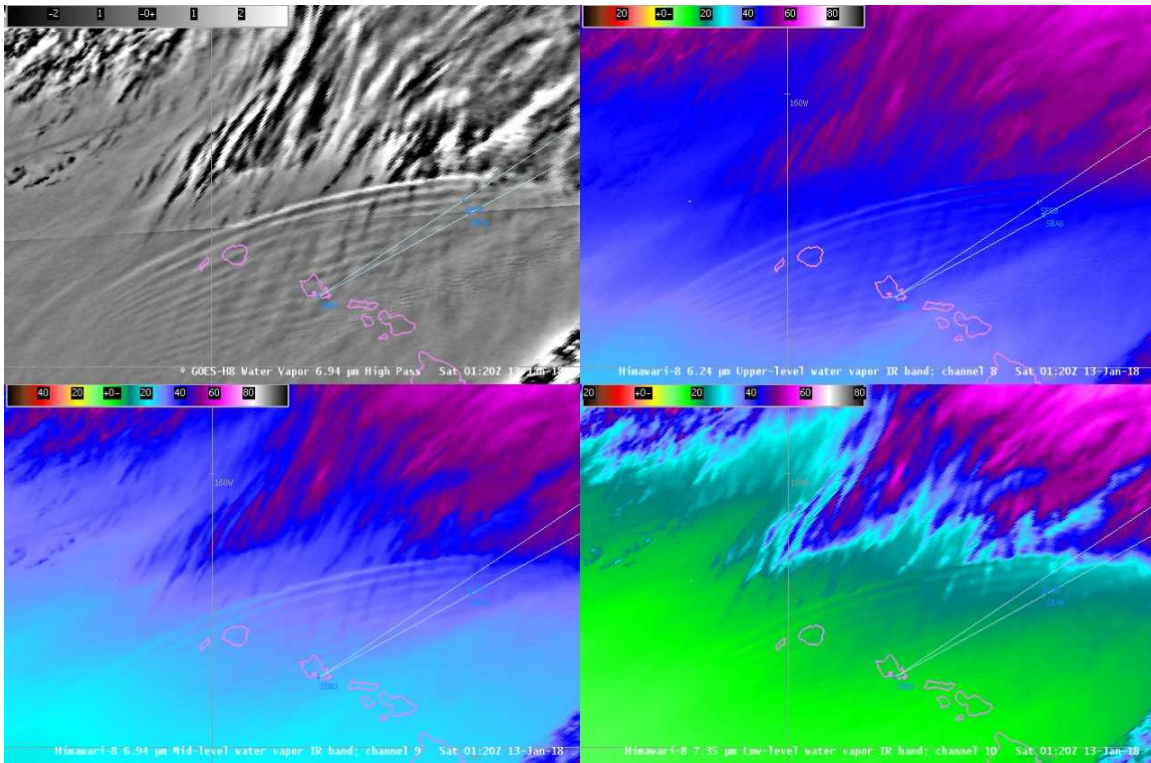

**Figure 22. Screen capture of the high-pass gravity wave product (upper left) with three other panels of water vapor imagery displayed in AWIPS2.**

**Publications and Conference Reports**

Wimmers, A. J., S. Griffin, J. Gerth, S. Bachmeier, S. Lindstrom, 2018: Observations of gravity waves with High-Pass filtering in the new generation of geostationary imagers and their relation to aircraft turbulence, *Wea. Forecast.* 33, 139-144.

Wimmers, A. J., S. Griffin, J. Gerth, S. Bachmeier, S. Lindstrom, 2017: Resolving “hidden gravity waves” with Himawari-8 imagery and its application to aircraft-scale turbulence, EUMETSAT annual conference, Rome.

Wimmers, A. J., S. Griffin, J. Gerth, S. Bachmeier, S. Lindstrom, 2017: Resolving gravity waves with Himawari-8 at the new limit of resolution, and the application to large-scale turbulence, AMS annual conference, Austin, Texas.

**5.4 Severe Storms Component of the GOES-R High-Impact Weather Theme**

**CIMSS Task Leader: Chris Velden**

**CIMSS Support Scientists: Dave Stettner (CIMSS), Jason Dunion (CIMAS)**

**NOAA Collaborators: Brad Pierce (STAR)**

**Budget: \$96,000**

**NOAA Long Term Goals:**

- Weather-Ready Nation

**NOAA Strategic Goals:**

- Serve society’s needs for weather and water
- Provide critical support for the NOAA mission



### **CIMSS Research Themes:**

- Satellite Meteorology Research and Applications
- Satellite Sensors and Techniques
- Environmental Models and Data Assimilation

### **Objective**

The severe storm component of this project aims to improve severe storms and hurricane analysis/prediction by building on mature research activities and applying novel GOES-R observing capabilities to leading-edge product and data assimilation methodologies.

### **Project Overview**

The CIMSS GOES-R High Impact Weather Research Theme project focuses on two major high impact weather events: fires and severe storms. The objective of the fires component of the research is to improve NWS WFO and IMET situational awareness during wildfire events. The fires component will have three sub-topics focusing on fire detection and characterization, smoke forecasting and data assimilation, and development of probabilistic estimates of lightning wildfire ignition sources. The severe storm component of this project aims to improve severe storms and hurricane analysis/prediction by building on mature research activities and applying novel GOES-R observing capabilities to leading-edge product and data assimilation methodologies. FY17 funding to CIMSS was reduced by \$300K over what was originally proposed, which has adversely impacted progress. Only the tropical cyclone applications portion of the severe storms focus area was funded in this period, and is reported on here.

### **Milestones with Summary of Accomplishments and Findings**

The two research foci supported in FY17 are: 1) explore the application and assimilation of GOES-16 Atmospheric Motion Vectors (AMVs) on fine time and space scales to better characterize the evolving mesoscale flows into and around severe storm development and hurricanes, and 2) improve tropical cyclone characterization using GOES-16 multispectral imagery and derived products. [Funding curtailments did not allow any R&D work on the other severe storm application foci originally proposed (these will be fully funded in FY18)]. The progress so far on these two tasks is summarized below.

#### ***Milestone 1: Application and Assimilation of High-resolution AMVs***

One of the principle benefits expected from GOES-16 is the improved temporal sampling of images from the ABI. In addition to qualitative uses by forecasters, the rapid refresh (1-5 min.) will allow for quantitative improvements in derived products normally associated with geostationary satellite imagery. One of those products is AMVs. The reasons we are optimistic that GOES-16 AMVs can be an important contributor to mesoscale analyses derive from recent and ongoing proxy studies (Velden et al. 2017). Our plan in this project is to build on these efforts as we also take advantage of GOES-16 capabilities and new AMV derivation methods towards the production of mesoscale AMV datasets with the goal of extracting wind information that benefits short-term forecasts and operational NWP.

For this project, we utilize the new (and novel) approaches of the GOES-16 AMV tracking algorithm developed under the GOES-R Algorithm Working Group (AWG) program (Bresky et al. 2012) , and focus on the smaller (meso) scales for AMV derivation, quality control, and applications, taking advantage of what the improved ABI temporal and spatial sampling will provide. The first goal is to optimize the algorithm settings, tuning, and AMV derivation methodologies to increase the data density and improve the ultimate quality to better capture smaller-scale flow fields. This process involves empirical testing and statistical validation of the





AMVs vs. existing GOES AMV datasets, rawinsonde observations, and other tropospheric wind datasets of opportunity.

### *Tropical Cyclone Applications*

During the 2017 hurricane season, AMV datasets were processed during selected events. The focus was on employing the GOES-16 1-min. meso scans when they were centered on a target tropical cyclone. An example of AMVs extracted for one time period during Hurricanes Harvey, Irma and Maria are shown in Figure 23, Figure 24, and Figure 25. The plotted vectors are thinned for viewing purposes, and shown in two colors representing upper (cyan) and lower (yellow) tropospheric coverage. The AMVs are derived from a combination of VIS, SWIR (3.9m), LWIR, and WV image triplets at nominal time resolutions (1-10mins) for each band. Datasets at hourly intervals were created for the entire lifecycles of Hurricanes Harvey, Irma and Maria.

In the 2nd half of FY17, we plan to start collaborations with experts in regional data assimilation and NWP (NCEP-EMC, AOML/HRD) to conduct AMV data impact experiments from the above cases. Locally, SDAT and HWRF will be the primary NWP tools for evaluation.

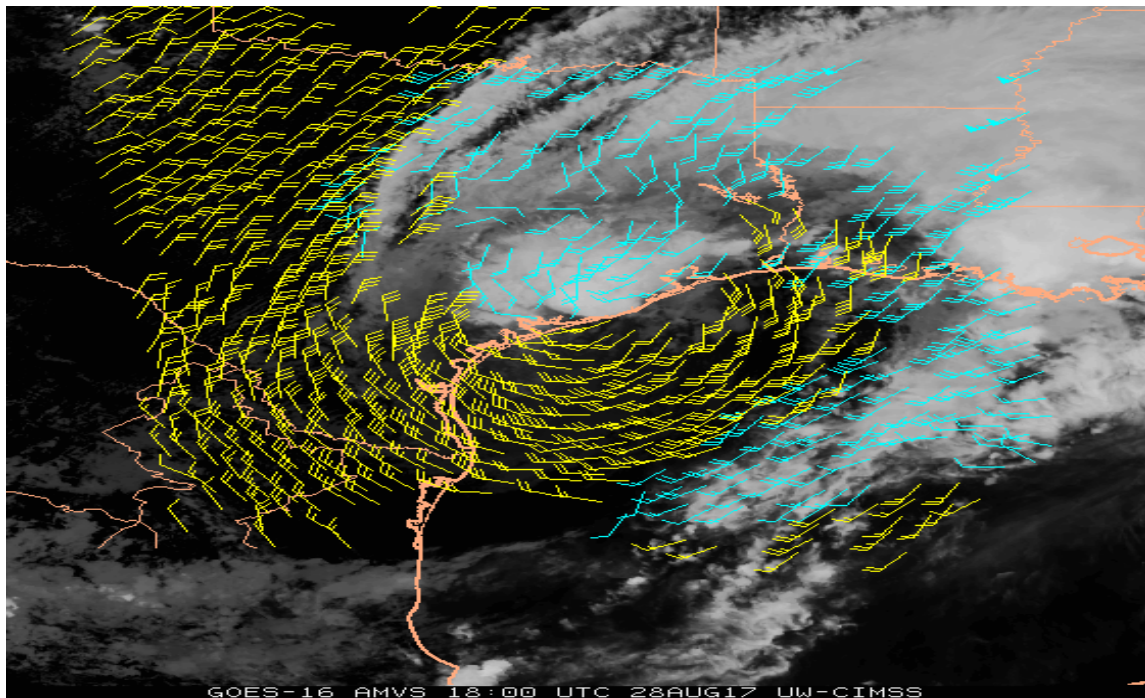

**Figure 23.** Plot of AMVs derived from a triplet of multispectral GOES-16 meso sector scan images during Hurricane Harvey (2017). Yellow (Cyan) vectors denote lower (upper) tropospheric flow.

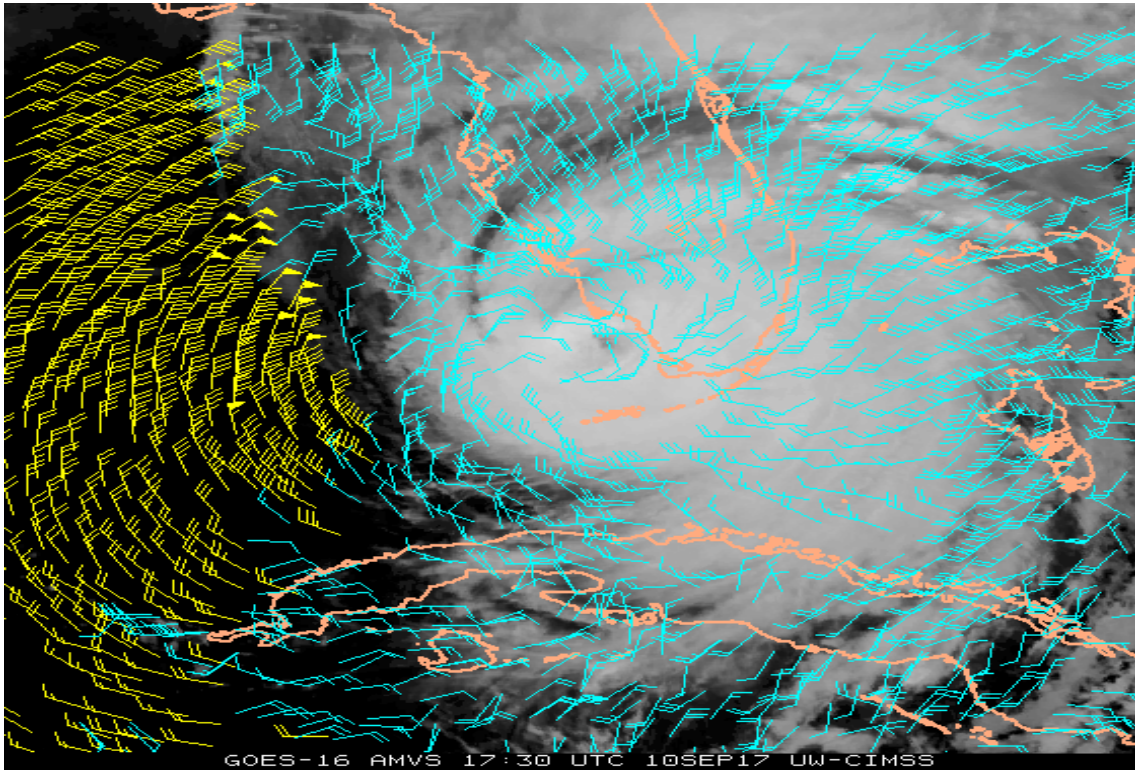

Figure 24. Plot of AMVs derived from a triplet of multispectral GOES-16 meso sector scan images during Hurricane Irma (2017). Yellow (Cyan) vectors denote lower (upper) tropospheric flow.

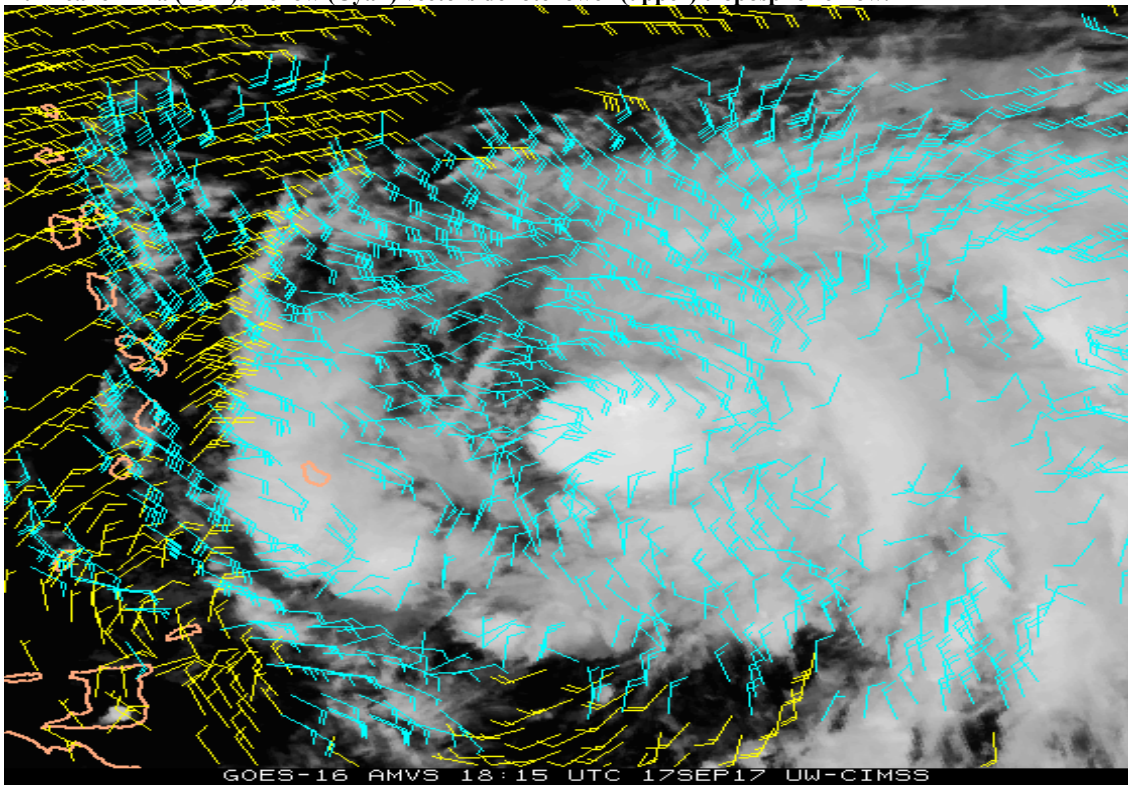
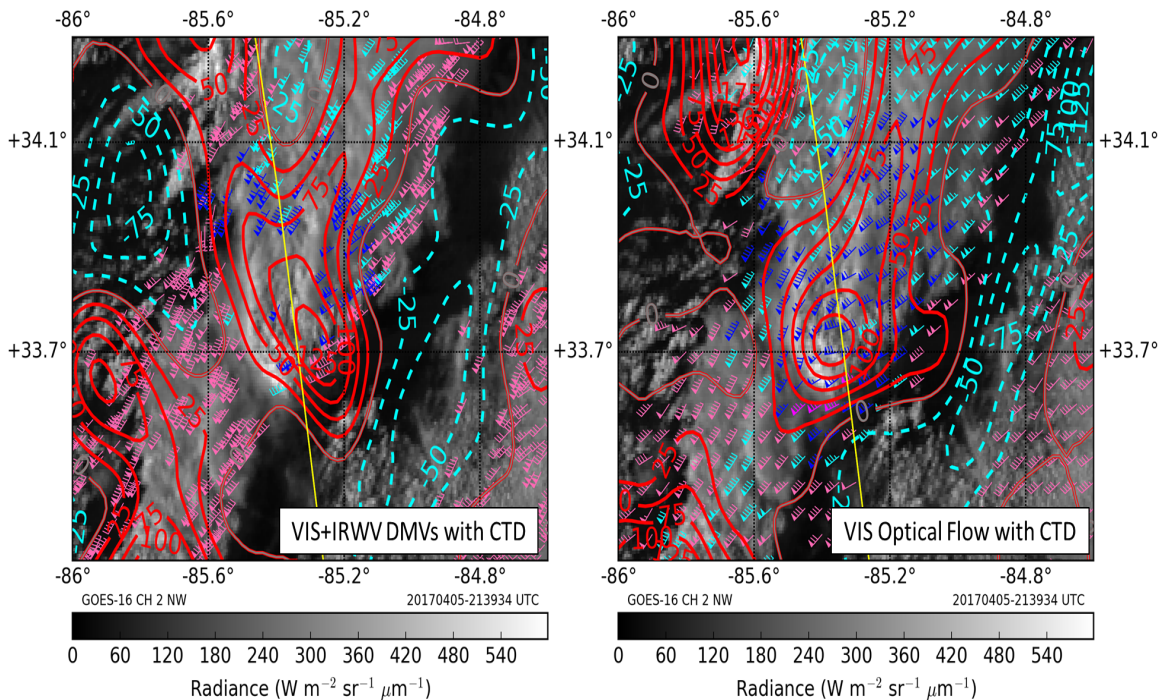

Figure 25. Plot of AMVs derived from a triplet of multispectral GOES-16 meso sector scan images during Hurricane Maria (2017). Yellow (Cyan) vectors denote lower (upper) tropospheric flow.

### Severe Local Storm Applications

The improved spatiotemporal sampling from the GOES-16 ABI will allow critical mesoscale flow features associated with severe local storms diagnostics and kinematics to be better observed. We are exploring both heritage and novel new AMV derivation methodologies that can identify key convective cloud-top variables associated with severe storm events. This work is being done in collaboration with John Mecikalski and Jason Apke at the University of Alabama-Huntsville, Jaime Daniels at NESDIS/STAR, and Bob Rabin at NOAA/NSSL. Preliminary attempts on case studies are encouraging. An example is shown in Figure 26, comparing two methodologies to derive AMVs over a severe convective complex. Further tuning experiments and analysis will be needed to verify the optimal processing strategies. Once the AMV processing is optimized for this application, we also plan to partner with data assimilation experts and conduct AMV data impact studies.



**Figure 26.** The GOES-16 channel 2 VIS imagery of a severe storm on 5 April 2017 over eastern Alabama with an overshooting top. Plotted are AMVs derived from GOES-16 VIS, IR and WV imagery from the NESDIS algorithm and subsequent cloud-top divergence (CTD) analysis (*Left*), and VIS vectors derived with a novel Optical Flow algorithm with CTD (*Right*). CTD is contoured with positive (negative) values in red (blue dash) every  $25 \times 10^{-5} \text{ s}^{-1}$ , and vectors are colored by pressure, with hot pink representing vectors at pressure (p) 500 hPa  $> p \geq 200 \text{ hPa}$ , cyan at  $200 \text{ hPa} \geq p > 175 \text{ hPa}$ , blue at  $175 \text{ hPa} \geq p > 150 \text{ hPa}$ .

### Milestone 2: Improve Tropical Cyclone Characterization Using Multispectral Imagery and Derived Products

The 16 channels on the GOES-16 ABI allow for multispectral combination products such as the pseudo-natural color and Saharan Air Layer (SAL) that are currently derived from MSG SEVIRI data. For this project, a focus of these derived-imagery products is on hurricane environment analyses in the Atlantic. Our longer-term plan is to expand and merge these products using the ABI imagery to cover the entire Atlantic, and explore hurricane-environment interaction cases.

An example of an experimental SAL product derived from GOES-16 ABI data is shown in Figure 27. For comparison, a companion SAL image is shown from the MSG SEVIRI. This work is being done in collaboration with Jason Dunion (UM/CIMAS), and he will visit CIMSS for a



week or two in May to fine-tune the derived products. Once the products are fully developed from ABI, we plan to showcase them as part of the GOES-16 NHC Proving Ground in 2018.

## Saharan Air Layer Product: 19 Aug 2017 12 UTC

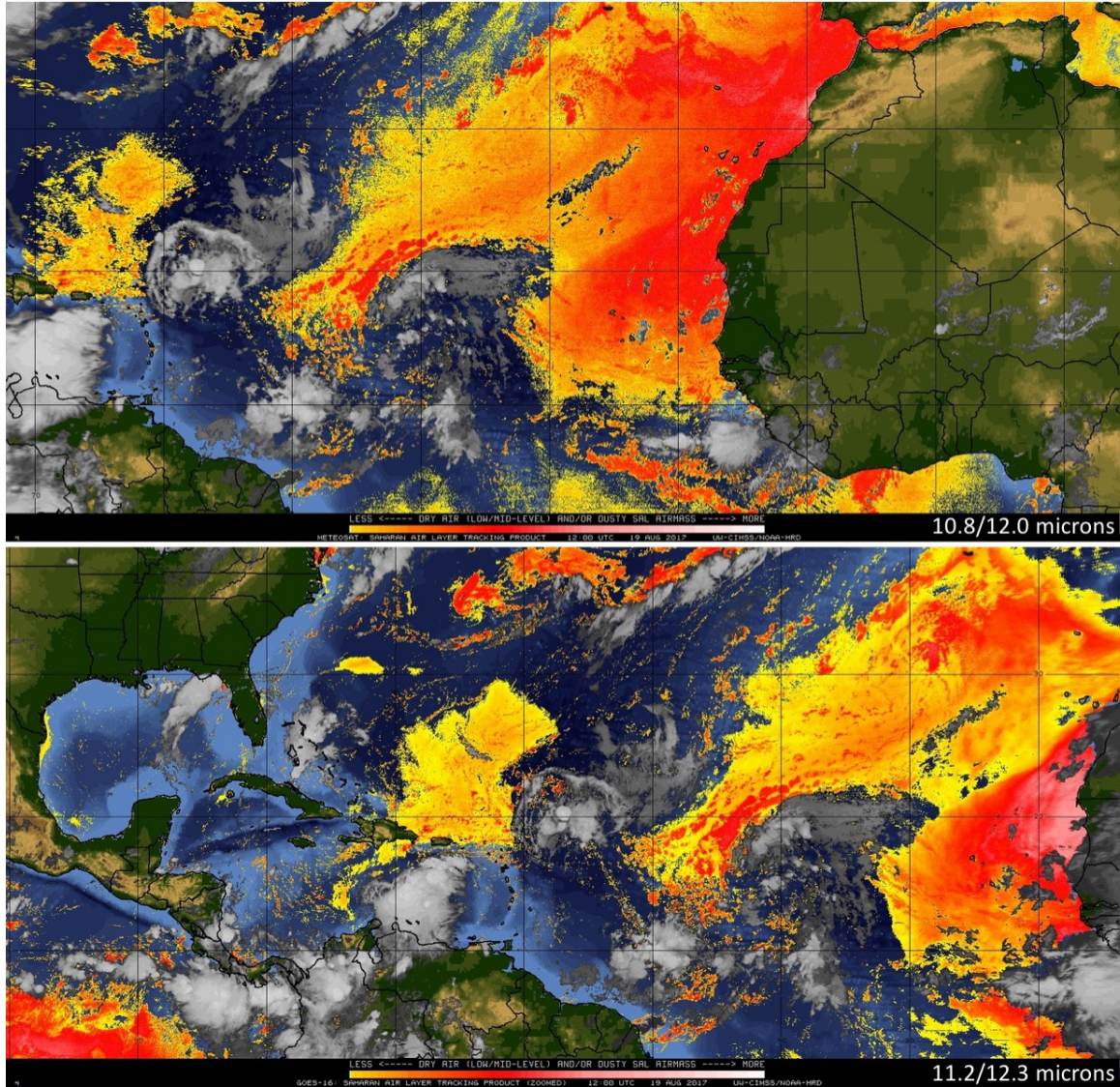

Figure 27. Example of experimental Saharan Air Layer (SAL) split-window derived imagery from concurrent MSG-SEVIRI (top) and GOES-16 ABI (bottom). The warm colors in the imagery depict dry air and especially dry/dusty air associated with air masses originating over the African Saharan desert.

### References

Bresky, W.C., J.M. Daniels, A.A. Bailey, and S.T. Wanzong, 2012: New Methods toward Minimizing the Slow Speed Bias Associated with Atmospheric Motion Vectors. *J. Appl. Meteor. Climatol.*, **51**, 2137–2151.



Velden, C., W.E. Lewis, W. Bresky, D. Stettner, J. Daniels, and S. Wanzong, 2017: Assimilation of High-Resolution Satellite-Derived Atmospheric Motion Vectors: Impact on HWRF Forecasts of Tropical Cyclone Track and Intensity. *Mon. Wea. Rev.*, **145**, 1107–1125.

### **5.5 ProbSevere: Train ProbSevere with GOES-16 Data**

**CIMSS Task Leader: John Cintineo**

**CIMSS Support Scientists: Justin Sieglaff, Jason Brunner**

**NOAA Collaborator: Michael Pavolonis**

**Budget: \$85,000**

#### **NOAA Long Term Goals:**

- Weather-Ready Nation

#### **NOAA Strategic Goals:**

- Serve society's needs for weather and water
- Provide critical support for the NOAA mission

#### **CIMSS Research Themes:**

- Satellite Meteorology Research and Applications

#### **Objective**

To train satellite-based predictors in the ProbSevere model with GOES-16 data.

#### **Project Overview**

Hazards from severe convective storms annually cause property losses in the U.S. exceeding \$1 billion and the loss of human lives. Accurate short-term forecasts of these storms are vital to the protection of life and property. In an effort to support severe weather warning operations through data fusion, the ProbSevere model was developed under a previous GOES-R Risk Reduction project. ProbSevere utilizes NWP, GOES, NEXRAD, and ground based lightning data to estimate the probability that a developing thunderstorm will produce severe weather up to 90 minutes in the future. ProbSevere has been shown to add 14 minutes of additional lead-time compared to traditional radar interrogation techniques. The lead-time is largely a result of the satellite component of ProbSevere. The spatial, temporal, and spectral attributes of the Advanced Baseline Imager (ABI) and the Geostationary Lightning Mapper (GLM) will allow the satellite component to have an even greater positive impact on accuracy, lead-time, and the ability to forecast storm severity in the absence of radar data. ProbSevere is a statistical model that is reliant on a training database to make predictions. Given that the GOES-R series of satellites are much more capable than the previous generation of GOES, on-orbit GOES-16 data must be used to retrain ProbSevere. Without this retraining effort, many of the critical GOES-R capabilities will go unused.

#### **Milestones with Summary of Accomplishments and Findings**

Automated satellite cloud object identification and tracking for ABI data has been optimized. Using numerous busy convective days in the spring and summer of 2017, tracking was optimized in a heuristic fashion, attempting to create objects and object-tracks similar to human pattern recognition. The increased temporal and spatial resolution of ABI compared to the legacy GOES imagers make identification and tracking more accurate, but with a significant runtime challenge (i.e., keeping up with identification/tracking in real-time was an obstacle). However, through



testing and manual evaluation, we have been able to faithfully track and identify clouds in an efficient, real-time manner CONUS-wide, with minimal tradeoffs to tracking accuracy.

A new lookup table for the normalized vertical growth rate predictor in ProbSevere (similar to 11- $\mu\text{m}$  brightness temperature cooling, but using the top-of-troposphere emissivity [Pavolonis 2010]) has been developed using approximately 4 months (April through July 2017) of ABI data. Figure 28 shows how the ABI predictor compares to the GOES-NOP predictor. The higher the ratio of conditional probabilities for a given growth rate value, the stronger it adds to the probability of severe. The ABI and NOP ratios for this growth rate predictor are similar for many values, but the ABI predictor has a much higher maximum ratio ( $\geq 8$ ) at very strong growth rates ( $\geq 6\% \text{ min}^{-1}$ ).

ProbSevere now exclusively uses GOES-16 for its satellite data source over the CONUS (until GOES-17 becomes operational). This incorporation will be in effect when ProbSevere becomes operational at NCEP-NCO.

The ProbSevere model was evaluated on independent data using both the GOES-16 ABI predictor and GOES-NOP predictors for the overlap period when both imagers were observing the same storms, in April through August 2018 (see the orange and yellow bars in Figure 29). ProbSevere with GOES-16 ABI increased the median leadtime to initial severe hazards by 4 min, while the critical success index (CSI) stayed the same. This result is for storms that were observed from early development to maturity. Thus, the GOES-16 growth rate predictor skilfully increases the leadtime in ProbSevere.

The glaciation rate predictor is not currently used in the GOES-16 version of ProbSevere. Through retraining, it was found that the glaciation rate did not differ substantially between severe and non-severe storms, and is thus not skillful. The investigators hypothesize (and looking at numerous cases has largely confirmed) that this is due to the fact that GOES-R ABI “sees” ice much sooner than GOES-NOP did, due to the presence of the 8.5- $\mu\text{m}$  channel and the higher temporal resolution. We are still working on incorporating this predictor into ProbSevere.

The GLM data have been explored but no robust training has been produced yet, due to data quality problems. These issues were partly resolved in GLM achieving provisional status in January 2018, so the training of GLM predictors in ProbSevere will most likely use convective days from 2018.

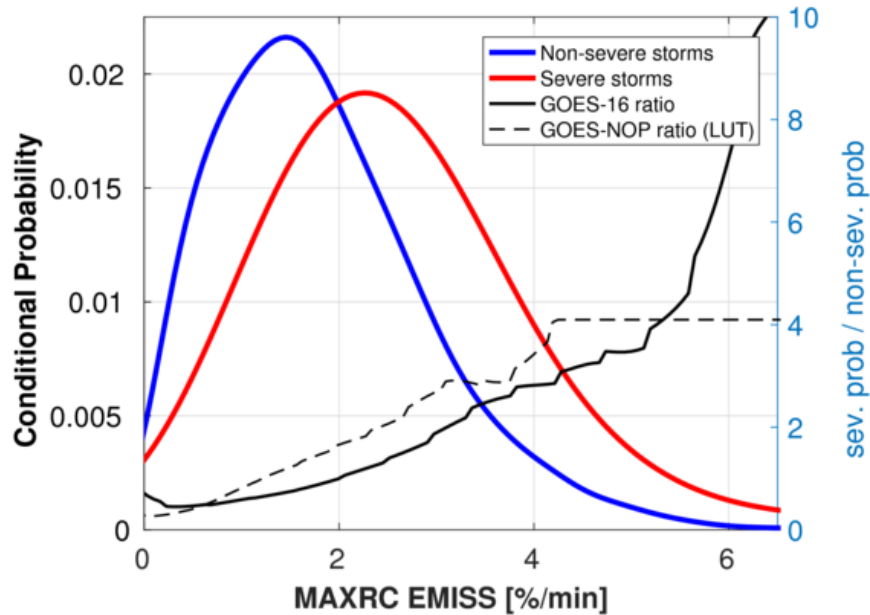

Figure 28. The GOES-16 severe and non-severe conditional probability distributions (red and blue lines) with the GOES-16 ratio of these two distributions (solid black lines). The GOES-NOP ratio is also superimposed (dashed black line). The magnitude of the ratio lines indicate how.

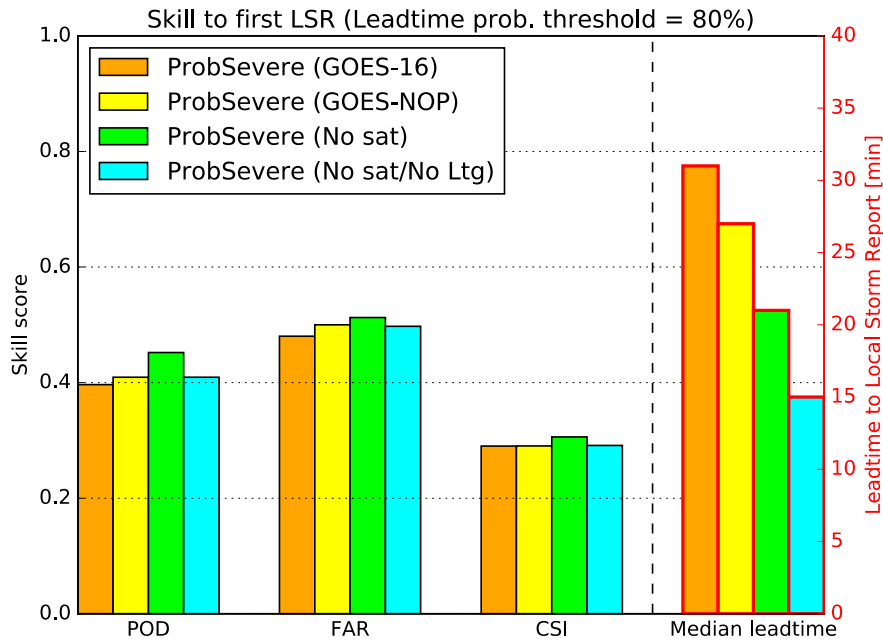

Figure 29. Skill scores, relative to initial local storm report (LSR), for storms that were well observed by GOES measurements from an early stage of development. A probability threshold of 80% was utilized. Note that the GOES-16 version (orange bar) of ProbSevere adds 4 minutes of lead-time compared to the corresponding GOES-NOP version (yellow bar).

### Publications and Conference Reports

Cintineo, J. L., M. J. Pavolonis, J. M. Sieglaff, D. T. Lindsey, L. Cronce, J. Gerth, B. Rodenkirch, J. Brunner, and C. Gravelle, 2018: The NOAA/CIMSS ProbSevere Model - incorporation of total lightning and validation. *Wea. Forecasting*, **33**, 331–345.



Cintineo, J. L., M. J. Pavolonis, J. M. Sieglaff, J. Brunner, and D. T. Lindsey, 2017: Next generation geostationary satellite observations in a multi-sensor severe weather nowcasting tool. *EUMETSAT Meteorological Satellite Conference*, Rome, Italy, 95

## References

Cintineo, J. L., Pavolonis, M. J.; Sieglaff, J. M. and Lindsey, D. T., 2014: An empirical model for assessing the severe weather potential of developing convection. *Weather and Forecasting*, 29(3), 639–653.

Cintineo, J. L., Pavolonis, M. J.; Sieglaff, J. M. and Heidinger, A. K., 2013: Evolution of severe and nonsevere convection inferred from GOES-derived cloud properties. *Journal of Applied Meteorology and Climatology*, 52(9), 2009–2023.

Pavolonis, M.J., 2010: Advances in Extracting Cloud Composition Information from Spaceborne Infrared Radiances – A Robust Alternative to Brightness Temperatures. Part I: Theory. *J. Appl. Meteor. Climatol.*, 49, 1992-2012, <https://doi.org/10.1175/2010JAMC2433.1>

## 6. CIMSS GOES-R Risk Reduction Program New 2017-2018

### 6.1 Integration of GOES-R/ABI data in Flood Mapping Software for Flood Monitoring and Forecasting

**CIMSS Task Leader: Jay Hoffman**

**CIMSS Support Scientist: David Santek**

**Budget: \$4,000**

#### NOAA Long Term Goals:

- Weather-Ready Nation

#### CIMSS Research Themes:

- Satellite Meteorology Research and Applications
- Satellite Sensors and Techniques

#### Objective

To support GMU in the development of a flood detection algorithm from GOES-R/ABI.

#### Project Overview

A river flood product was originally developed for VIIRS at George Mason University (GMU). CIMSS has provided support for this product to run routinely using direct broadcast VIIRS data. Building on this partnership, CIMSS is tasked with providing support in acquiring the GOES-16 data as the product is being developed at GMU. By taking advantage of the frequent imaging pattern, the ABI based product will be built on a mosaic of cloud-free observations and therefore provide greater coverage than can be achieved from a polar orbiting imagers.

#### Milestones with Summary of Accomplishments and Findings

CIMSS has provided support in acquiring some GOES-16 data to begin testing the flood detection algorithm. Plans are being made to purchase new hardware to be able to begin running the algorithm routinely in the upcoming Year 2 of the project.





A product example in Figure 30 shows results from a test case using ABI data after Hurricane Harvey. The flooding in South Texas appears as shades of yellow and red.

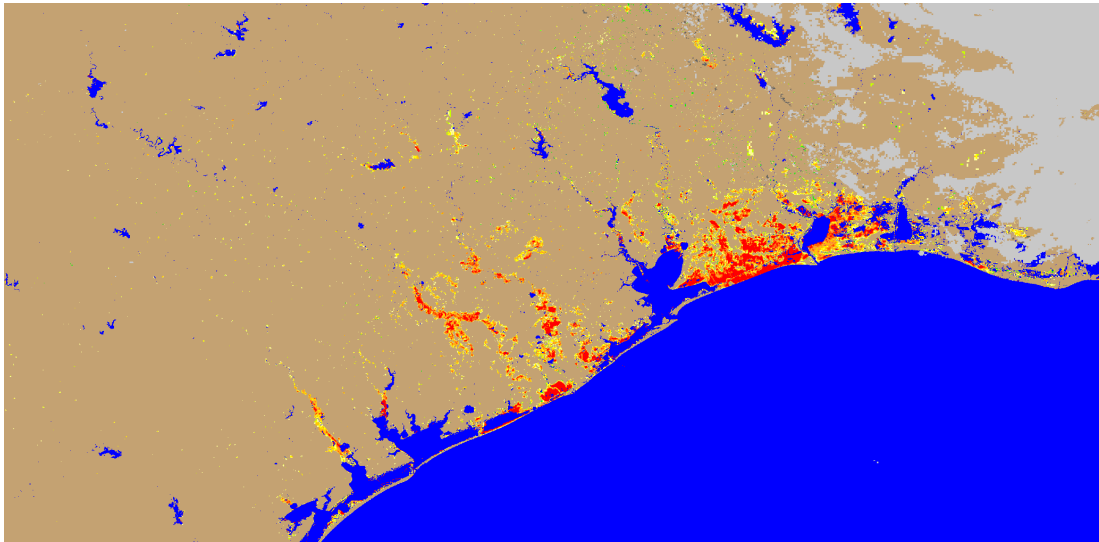

Figure 30. Example ABI flood product from 31 Aug 2017 showing flooding in South Texas after Hurricane Harvey.

## **6.2 ProbSevere: Upgrades and Adaption to Offshore Thunderstorms**

**CIMSS Task Leader: Justin Sieglaff**

**CIMSS Support Scientists: John Cintineo, Jason Brunner, Lee Cronic**

**NOAA Collaborator: Michael Pavolonis**

**Budget: \$120,774**

### **NOAA Long Term Goals:**

- Weather-Ready Nation

### **NOAA Strategic Goals:**

- Serve society's needs for weather and water
- Provide critical support for the NOAA mission

### **CIMSS Research Themes:**

- Satellite Meteorology Research and Applications

### **Objective**

Improving short-term prediction of continental and offshore thunderstorm severity through data fusion.

### **Project Overview**

Severe thunderstorms endanger lives and can cause damage in excess of \$10 billion dollars in a single year (USA Today, 2016). Timely and accurate severe thunderstorm and tornado warnings are critical for protecting life and property. The Science and Technology Plan of the NWS's Weather-Ready Nation Roadmap (NWS 2013) highlights the value of data fusion techniques for improving operational decision-making, including severe weather warning operations. In an effort to support severe weather warning operations through data fusion, the NOAA/CIMSS ProbSevere model (Cintineo et al., 2013; Cintineo et al., 2014, Cintineo et al., 2018) was developed under a



previous GOES-R Risk Reduction project. ProbSevere utilizes NWP, GOES, NEXRAD, and ground based lightning data to estimate the probability that a developing thunderstorm will produce severe weather up to 90 minutes in the future, including hazard specific predictions of severe hail, severe wind gusts, and tornadoes. This project focuses on feedback from NWS user requests for improving ProbSevere. The two primary topics include upgrades to ProbSevere for improved WFO severe weather warning operations within the current warning paradigm (as well as within the FACETS warning paradigm) and developing a version of ProbSevere for predicting which offshore thunderstorms will produce gale force winds. The Ocean Prediction Center (OPC) requested that an offshore version of ProbSevere be developed to assist with their real-time warnings to mariners.

## **Milestones with Summary of Accomplishments and Findings**

### ***Progress toward the Upgrades to ProbSevere for Improved WFO Severe Weather Warning Operations***

Based on NWS forecaster feedback, trends in ProbSevere probabilities (and associated predictors) are important for improving severe weather warning operations. Forecasters largely manually estimate these temporal trends, and many forecasters have requested, if possible, the development of an AWIPS-2 time series tool for displaying temporal trends in ProbSevere output. Existing AWIPS-2 tools have been explored in collaboration with the AWIPS Hazards Services group. Extending the capabilities of the MegaWidgets AWIPS tool has been identified as the best path forward.

In support of a separate GOES-R Risk Reduction project, ProbSevere has been retrained with on-orbit GOES-16 ABI data collected over the course of 2017. Figure 31 shows that the GOES-16 version of ProbSevere provides four minutes of additional lead-time (to the first report of severe weather), in the median, compared to the corresponding GOES-NOP results. The results shown in Figure 31 are constrained to storms where the geostationary satellites were able to observe the evolution from cumulus to cumulonimbus. The GOES-16 version of ProbSevere attains the additional four minutes of lead-time without sacrificing any skill compared to the GOES-NOP version. We expect the impact of the GOES-R series capabilities, on ProbSevere performance, to increase as ProbSevere development and optimization continue.

### ***Progress toward the Development of an Offshore Version of ProbSevere***

ProbSevere for offshore regions (most of which is void of any NEXRAD coverage) must utilize satellite and lightning observations, as well as numerical weather prediction as predictors. The CONUS version of ProbSevere is able to utilize NEXRAD data, not only to assess and help forecast storm intensity, but also for identifying and tracking storm cells. Extraction and tracking of convective storms in geostationary satellite data is far more complicated since, from a satellite perspective, adjacent storms commonly merge. The offshore version of ProbSevere cannot rely on NEXRAD so alternate storm identification and tracking procedures need to be developed. As a first step, we have employed the method of Pavolonis et al. (2018) to identify and track convective cells using geostationary infrared measurements. Using this approach, we have started developing a large data set for training, testing, and validating the offshore version of ProbSevere. The data set currently consists of storms, within OPC's Atlantic region of responsibility, from April through June 2017. The storms were sampled at 5-minute intervals using the ABI CONUS domain. A portion of the data set is used to construct basic statistics on cloud vertical growth, as captured by the ABI. As in Pavolonis et al. (2018), those statistics will be used to compute cloud vertical growth rate anomalies. A sample distribution of cloud vertical growth is shown in Figure



32, where the blue lines indicate where in the distribution the 2, 4, 6, 8, and 10 standard deviation cloud vertical growth rate anomalies occur. As shown in previous ProbSevere research (e.g., Cintineo et al. (2013)), large vertical growth rates are generally associated with the development of more intense storms. A next step is to relate the cloud vertical growth rate anomalies to lightning activity captured by the GLM and ground-based sensors.

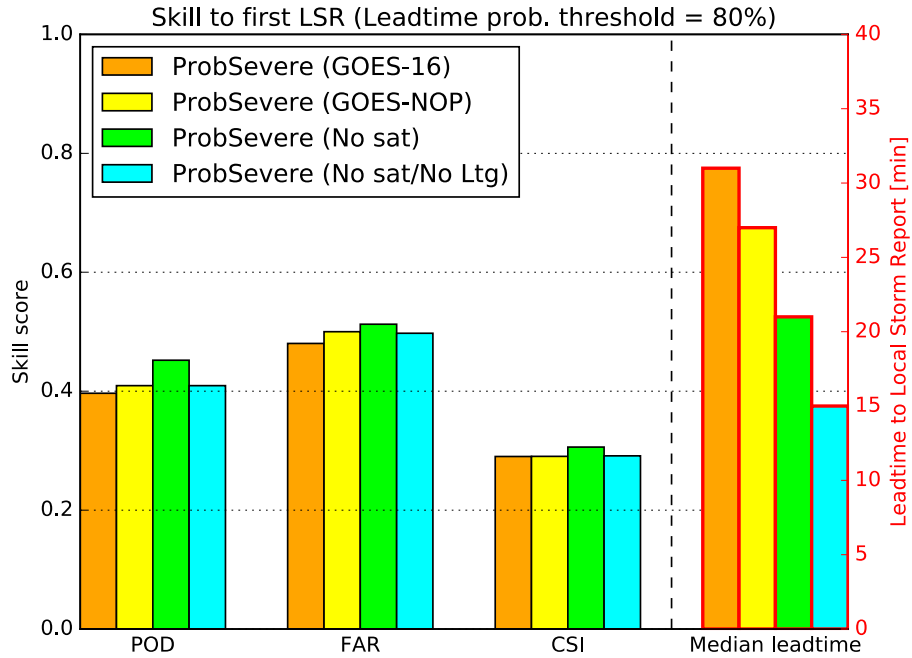

Figure 31. Skill scores, relative to initial local storm report (LSR), for storms that were well observed by GOES measurements from an early stage of development. A probability threshold of 80% was utilized. Note that the GOES-16 version (orange bar) of ProbSevere adds 4 minutes of lead-time compared to the corresponding GOES-NOP version (yellow bar).

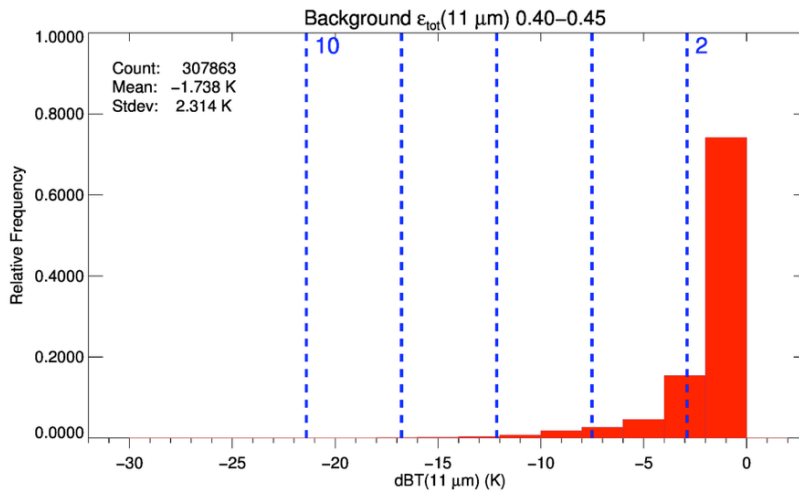

Figure 32. The distribution of GOES-16 ABI-derived cloud vertical growth rates for over 300,000 vertically growing clouds. The vertical blue dashed lines indicate number of standard deviations above the mean (2 standard deviations above the mean on the right to 10 standard deviations above the mean on the left). The vertical growth rate distribution accounts for initial state of each cloud feature being tracked.



## Publications and Conference Reports

Cintineo, J. L., M. J. Pavolonis, J. M. Sieglaff, D. T. Lindsey, L. Cronce, J. Gerth, B. Rodenkirch, J. Brunner, and C. Gravelle, 2018: The NOAA/CIMSS ProbSevere Model - incorporation of total lightning and validation. *Wea. Forecasting*, **33**, 331–345.

Cintineo, J. L., M. J. Pavolonis, J. M. Sieglaff, J. Brunner, and D. T. Lindsey, 2017: Next generation geostationary satellite observations in a multi-sensor severe weather nowcasting tool. *EUMETSAT Meteorological Satellite Conference*, Rome, Italy, 95

## References

Cintineo, J. L., Pavolonis, M. J.; Sieglaff, J. M. and Lindsey, D. T., 2014: An empirical model for assessing the severe weather potential of developing convection. *Weather and Forecasting*, 29(3), 639–653.

Cintineo, J. L., Pavolonis, M. J.; Sieglaff, J. M. and Heidinger, A. K., 2013: Evolution of severe and nonsevere convection inferred from GOES-derived cloud properties. *Journal of Applied Meteorology and Climatology*, 52(9), 2009–2023.

NWS, 2013: National Weather Service Weather-Ready Nation Roadmap. [Available online at: [http://www.nws.noaa.gov/com/weatherreadynation/files/nws\\_wrn\\_roadmap\\_final\\_april17.pdf](http://www.nws.noaa.gov/com/weatherreadynation/files/nws_wrn_roadmap_final_april17.pdf)]

Pavolonis, M.J., J. Cintineo, and J. Sieglaff, 2018: Automated Detection of Explosive Volcanic Eruptions Using Satellite-derived Cloud Vertical Growth Rates, *Journal Geophysical Research*, *To be submitted*.

USA Today, 2016: Tornadoes, severe storms cost \$10 billion in 2015. [Available online at: <http://www.usatoday.com/story/weather/2016/01/03/tornadoes-severe-storms-insured-losses/78234474/>]

## 6.3 Improving the Assimilation of High-Resolution GOES-16 Water Vapor Variables and Atmospheric Motion Vectors in the HWRF Model

**CIMSS Task Leader: Jun Li**

**CIMSS Support Scientists: Chris Velden, Jinlong Li, William E. Lewis, and Dave Stettner**

**NOAA Collaborators: Jason Sippel (NOAA/NHC), Zhan Zhang (NOAA/EMC), and Timothy J. Schmit (CoRP/STAR/NESDIS)**

**Budget: \$130,000**

### NOAA Long Term Goals:

- Climate Adaptation and Mitigation
- Weather-Ready Nation

### NOAA Strategic Goals:

- Serve society's needs for weather and water
- Support the nation's commerce with information for safe, efficient and environmentally sound transportation
- Provide critical support for the NOAA mission



### **CIMSS Research Themes:**

- Satellite Meteorology Research and Applications
- Satellite Sensors and Techniques

### **Objective**

The objective is to improve the assimilation of high resolution moisture and atmospheric motion vector (AMV) information from GOES-R series satellites in NOAA's operational HWRF model.

### **Project Overview**

Reliable forecasts of landfalling tropical cyclones (TCs) such as Hurricane Sandy (2012), Matthew (2016), Harvey (2017), Irma (2017) and Maria (2017) are critical for decision making and better preparation. Obtaining good TC intensity forecasts remains one of the most challenging aspects in NOAA operations. Observations of atmospheric water vapor variables and winds in the TC environment as well as in the inner core at high spatiotemporal resolution are very important to the prediction of the storm evolution and landfall impacts. Optimizing the assimilation of that information into the operational Hurricane WRF (HWRF) model is a vital step towards improving TC forecasts. To help address this need, the Advanced Baseline Imager (ABI) (Schmit et al. 2005; 2007) onboard NOAA's next generation of geostationary weather satellites (GOES-R series), beginning with GOES-16 launched on 19 November 2016, will routinely provide high temporal (every 5 minutes) and spatial (2 km) resolution moisture variables and atmospheric motion vector (AMV) information not previously available. This proposed work is to optimize the impact of the high spatiotemporal resolution GOES-R series water vapor information and AMVs for improving TC analyses and forecasts in HWRF. In particular, our study will focus on using GOES-16 observations in the analysis-sensitive regions associated with the TC near-environment, exploring and optimizing the effective assimilation of these data into HWRF for improving TC moisture, wind, track, and intensity forecasts.

### **Milestones and Summary of Accomplishments and Findings**

#### ***The forward operator has been implemented into hybrid GSI on S4 for LPW assimilation studies***

The layered precipitable water (LPW) forward operator has been implemented into the latest version of GSI. Codes are developed and added into GSI by taking into account the different methodologies between LPW generation and assimilation (e.g., the three LPWs are produced in sigma levels: 0.3 – 0.7, 0.7 – 0.9 and 0.9 – 1.0 in GOES-R series product generation, while the GSI assimilation system is based on the vertical pressure levels). The hybrid GSI with LPW operator included inside is ready for GOES-16 LPW and AMV assimilation.

#### ***The GOES-16 ABI LPWs and AMVs for recent hurricane cases (Harvey, Irma and Maria) in 2017 have been processed and ingested into BUFR for assimilation experiments***

The LPW and AMV data from GOES-16 ABI have been processed and generated with quality control (QC) for recent hurricanes (Harvey, Irma and Maria). LPWs are from clear skies and AMVs are from mesoscale sectors, the available AMV data are: Ch 02 VIS, Ch 07 SWIR, Ch 08 WVCT, and Ch 14 IR. Both AMVs and LPWs have been converted to BUFR format for GSI to assimilate.



**Initial experiments on assimilating GOES-16 ABI LPWs and AMVs started with SDAT, and positive impact found on Harvey forecasts**

GOES-16 ABI AMV and LPW assimilation experiments have been conducted for recent hurricanes (Harvey, Irma and Maria). SDAT (WRF-ARW v3.6.1 forecast system with 12 km resolution together with GSI assimilation system) is used assimilation experiments and impact studies. The control run contains the assimilation of conventional data from GTS (Global Telecommunication System) and satellite data from AMSU-A, IASI, ATMS and CrIS. The other three experiments include:

- Control+CCRS, adding SNPP CrIS cloud-cleared radiances (CCRs) to control;
- Control+LPW, adding three LPWs to control;
- Control+AMVs, adding AMVs to control.

Data are assimilated every 6 hours followed by 72 hour forecasts. Figure 33 shows the assimilation and forecast experiments schemes. The experiments are designed to address whether the new satellite information (GOES-16) provides value-added impact on TC forecasts.

**Experiments on Hurricane Harvey (2017)**

WRF-ARW v3.6.1: 12 km horizontal resolution (400\*300), 52 vertical layers from surface to 10hPa  
GSI v3.3: 3D-Var Data Assimilation Method

Hurricane Harvey (2017)

- Assimilation : Aug 23 00z to Aug 25 18z, 2017
- Forecasts: Aug 23 12z to Aug 28 18z, 2017
- Assimilation every 6 hour, 10 groups in statistics



Experiment	GTS	AMSU-A	IASI	ATMS	CrIS (org)	CrIS CCRs	LPW	AMVs
<b>CNTRL</b>	✓	✓	✓	✓	✓			
<b>CNTRL+CCRs</b>	✓	✓	✓	✓	✓	✓		
<b>CNTRL+LPW</b>	✓	✓	✓	✓	✓		✓	
<b>CNTRL+AMVs</b>	✓	✓	✓	✓	✓			✓

CCRs: CrIS cloud-cleared radiances (CCRs) in cloudy skies;  
GOES-16: Three layered precipitable water (LPW) from ABI at: 0.3 - 0.7, 0.7 - 0.9, and 0.9 – 1.0 in sigma level.

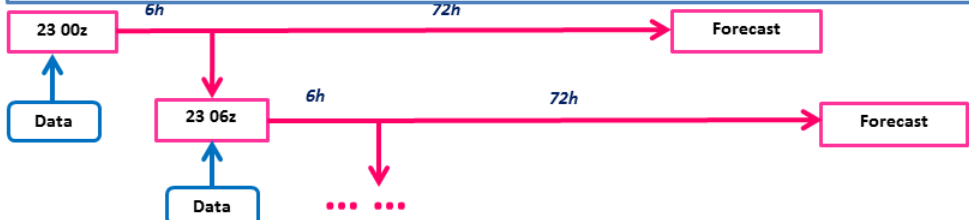
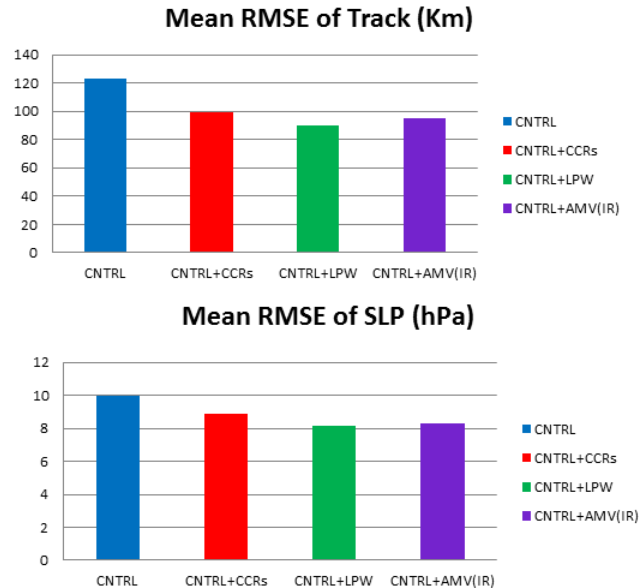

Figure 33. Data assimilation and forecast experiment schemes for hurricane Harvey (2017).

The hurricane track (HT) and central sea level pressure (SLP) Root Mean Square Error (RMSE) have been computed against the best track estimates from National Hurricane Center (NHC). Figure 34 shows the mean HT and SLP RMSE from control run and the three experiments for Hurricane Harvey (2017). It can be seen that, the new information from GOES-16 (either LPW or AMV) improves the control run, especially for later forecast hours (after 42 hours) for this Harvey case. The atmospheric temperature, moisture, wind (U, V) profile forecasts are also improved with new GOES-16 ABI information assimilated into SDAT when compared with



RAOBs (not shown). In addition, the cloud-cleared radiances (CCRs) from CrIS also improve the control run, indicating the importance of assimilating atmospheric sounding information in cloudy skies for improving the TC forecasts. Similar DA experiments in HWRF is ongoing at CIMSS, the goal is to improve TC forecasts with HWRF by better assimilating combined information from GOES-R series and JPSS series satellites.



**Figure 34. The mean HT (km) (upper) and SLP (hPa) (lower) RMSE from control run and the three assimilation experiments for Hurricane Harvey (2017).**

The ongoing work is focused on HWRF/GSI assimilation of GOES-16 ABI new information (moisture and AMVs) for Hurricane Harvey (2017, Irma (2017) and Maria (2017). In addition, combination of new information altogether for impact studies, as well as comparison between ABI radiance assimilation and LPW assimilation, etc., are also be conducted.

### Publications and Conference Presentations

Wang, Pei, Jun Li, Timothy J. Schmit, Jiazhen Lu, Bing Lu, Yong-Keun Lee, Agnes H. N. Lim, Jinlong Li, Zhiquan Liu, Chian-Yi Liu, and Wei Han, 2018: Impact of Moisture information from Advanced Himawari Imager Measurements on Heavy Precipitation Forecasts over land in a regional NWP model, *Journal of Geophysical Research – Atmospheres* (conditionally accepted).

Lee, Yong-Keun, Jun Li, Zhenglong Li, and Tim Schmit, 2017: Atmospheric temporal variations in the pre-landfall environment of Typhoon Nangka (2015) observed by the Himawari-8 AHI, *Asia-Pacific Journal of Atmospheric Sciences*. DOI:10.1007/s13143-017-0046-z.

Lee et al., 2018: Validation of GOES-16 atmospheric precipitable water and instability indices products for operational applications, 98th American Meteorological Society Annual Meeting, 07 – 12 January 2018, Austin, TX.

Li et al., 2018: All-sky layered precipitable water products from ABI/AHI and their applications in nowcasting and forecasting the severe storms, 98th American Meteorological Society Annual Meeting, 07 – 12 January 2018, Austin, TX.



## **6.4 Assimilation of High Resolution GOES-R ABI Infrared Water Vapor and Cloud Sensitive Radiances using the GSI-based Hybrid Ensemble-variational Data Assimilation System**

**CIMSS Task Leader: Jason Otkin**

**CIMSS Support Scientist: Yafang Zhong**

**Budget: \$56,000**

### **NOAA Long Term Goals:**

- Weather-Ready Nation

### **NOAA Strategic Goals:**

- Serve society's needs for weather and water

### **CIMSS Research Themes:**

- Satellite Meteorology Research and Applications
- Environmental Models and Data Assimilation

### **Objective**

The primary objective of the project is to extend the capabilities of the operational GSI-based hybrid data assimilation system to assimilate ABI infrared brightness temperatures and to assess their impact on convection forecasts in high-resolution numerical weather prediction models.

### **Project Overview**

In this collaborative project between the University of Wisconsin-Madison and the University of Oklahoma, we will extend the capabilities of the operational GSI hybrid data assimilation system to assimilate infrared brightness temperatures from the GOES-16 ABI sensor in high-resolution numerical weather prediction models. This goal will be accomplished by 1) modifying the GSI so that high-resolution ensemble output from the convection-permitting model can be used instead of coarse-resolution ensemble output from the Global Forecasting System, 2) updating cloud hydrometeor variables during the data assimilation step, 3) improving the use of GOES-16 ABI water vapor and cloud sensitive brightness temperatures by refining data quality procedures, 4) using high-resolution infrared land surface emissivity databases, and 5) exploring the use of all-sky bias correction and observation error methods. We will also test different data assimilation configurations. The impact of assimilating water vapor and cloud sensitive infrared brightness temperatures on convection forecasts will be assessed using case study experiments.

### **Milestones with Summary of Accomplishments and Findings**

The project progressed as planned during this reporting period. Specifically, co-investigators at the University of Oklahoma made substantial progress in regard to extending the capabilities of the GSI system so that it can assimilate both clear and cloudy sky brightness temperatures from the ABI sensor. This includes code development and testing to ingest pre-processed ABI data in netcdf format into the GSI, treating the ABI observations as a new observation type, and linking the newest version of the CRTM (version 2.3) to the GSI. In addition, a case study containing a significant severe weather event across the central U.S. was selected for this project. A baseline experiment for this case was performed in which both conventional and radar observations were assimilated. Subsequent experiments will assimilate all-sky ABI brightness temperatures with and without using bias correction. Ongoing work includes assisting efforts to update the GSI/CRTM so that it can use the University of Wisconsin surface infrared emissivity database and developing or enhancing methods to improve quality control and to apply appropriate bias corrections to the





all-sky infrared observations. Given the preliminary nature of the results, they will be discussed in greater detail in subsequent reports.

### **Publications and Conference Reports**

None during the current reporting period; however, publications describing results from the data assimilation experiments will be submitted later in the project.

### **6.5 Using Multi-sensor Observations for Volcanic Cloud Detection, Characterization, and Improved Dispersion Modeling**

**CIMSS Task Leader: Justin Sieglaff**

**CIMSS Support Scientist: John Cintineo**

**NOAA Collaborator: Michael Pavolonis**

**Budget: \$54,000**

#### **NOAA Long Term Goals:**

- Weather-Ready Nation

#### **NOAA Strategic Goals:**

- Serve society's needs for weather and water
- Support the nation's commerce with information for safe, efficient and environmentally sound transportation
- Provide critical support for the NOAA mission

#### **CIMSS Research Themes:**

- Satellite Meteorology Research and Applications
- Satellite Sensors and Techniques
- Environmental Models and Data Assimilation

### **Objective**

We will continue to develop an advanced volcanic ash detection and characterization system and ensure results of the system can be integrated into volcanic ash dispersion models.

### **Project Overview**

GOES-R will provide unprecedented capabilities to detect and track hazardous volcanic clouds. These capabilities, however, will only be fully realized using automated algorithms as the impressive GOES-R data volume makes volcanic eruption detection, solely using manual analysis of imagery, impossible. To ensure that the full spectral, spatial, and temporal capabilities of GOES-R are utilized for volcanic cloud monitoring, the Volcanic Cloud Analysis Toolkit (VOLCAT) was developed. VOLCAT utilizes spectral, spatial, and temporal metrics provided by GOES-R to detect and characterize volcanic ash clouds (VOLCAT can actually be applied to nearly any geostationary or low earth orbit sensor). This project builds upon previous research by incorporating additional key data sources into VOLCAT, performing several case studies, and developing an application that utilizes VOLCAT to improve operational volcanic ash dispersion modeling. The project directly addresses NWS research priorities A (improved model forecasts) and B (improved situational awareness) and is a natural progression of a pre-existing line of (successful) research. This project also addresses several operational challenges associated with tracking and forecasting volcanic clouds, which are a well-known aviation hazard. NOAA operates two Volcanic Ash Advisory Centers (VAACs) and three Meteorological Watch Offices (MWO) with operational volcanic hazard monitoring and forecasting responsibilities. NOAA's



total area of responsibility covers a very large region that stretches from the Western Pacific to the Eastern Caribbean and from Alaska to Ecuador. Thus, volcanic cloud monitoring and forecasting is an important component of NOAA operations.

### **Milestones with Summary of Accomplishments and Findings**

- During 2017 we began generating GOES-16 VOLCAT products in near real-time for internal use. The real-time processing was initially used to facilitate the optimization of the VOLCAT algorithms for GOES-16 ABI measurements. Optimization activities included tuning thresholds related to cloud object identification, selection, and tracking. Some GOES-16 performance issues, related to L1b data quality, remain.
- GOES-16 volcanic eruption alerts, from CONUS and full disk scans, were provided to the Washington VAAC. The VOLCAT algorithms are designed to utilize the spectral, spatial, and temporal capabilities of the GOES-R ABI for early eruption detection. The GOES-16 alerts have already detected several eruptive events not detected using any other means. Thus, the long-term impact on VAAC operations is likely to be significant. The Washington VAAC has already issued several volcanic ash advisories in direct response to GOES-16 VOLCAT alerts (see Figure 35).
- The performance of the VOLCAT website was significantly improved, thereby giving users quicker access VOLCAT product images. A database was deployed to manage the very large number of product images generated by VOLCAT. The database improved the load time of image animations by an order of magnitude. In addition, new overlay tools and options were added at the request of VAAC users.
- An automated volcanic cloud time series capability was developed. Time series of volcanic cloud properties, such as area and total mass of ash (Figure 36), can be used to derive eruption source parameters required to constrain dispersion model forecasts. The time series tool is a “one of a kind” capability. If resources allow, the time series capability will be used to generate eruption source parameters in near real-time. The eruption source parameters would be subsequently fed into NOAA’s operational dispersion model, HYSPLIT.
- Since renewed activity began in December 2016, VOLCAT automatically detected many of the numerous explosive events produced by Bogoslof volcano in the Aleutian Islands (Alaska). In close collaboration with the USGS Alaska Volcano Observatory (AVO), the VOLCAT satellite-based alerting capability was compared to the infrasound and ground-based lightning alerting capabilities managed by the AVO. The goal was to determine how best to combine these different alerting capabilities. The infrasound alerts identified the most events. Lightning was also found to be a powerful tool for early eruption detection in regions where meteorological lightning is climatologically rare, such as the in the Aleutian Islands, where Bogoslof is located. Most of the failures in the VOLCAT satellite-based alerting tool occurred when higher-level metrological clouds obscured the resulting volcanic cloud. Two of the events correctly identified by the VOLCAT satellite-based alerts did not trigger lightning or infrasound alerts. Thus, satellite, infrasound, and lightning are needed to ensure early detection of eruptions. Work is underway to integrate ground-based (Earth Networks) and GLM lightning into the VOLCAT alerting tool. Integration of infrasound and VOLCAT alerts is more complicated. As an initial step, the VOLCAT alerts will be integrated into the infrasound alert manager used internally by AVO scientists.

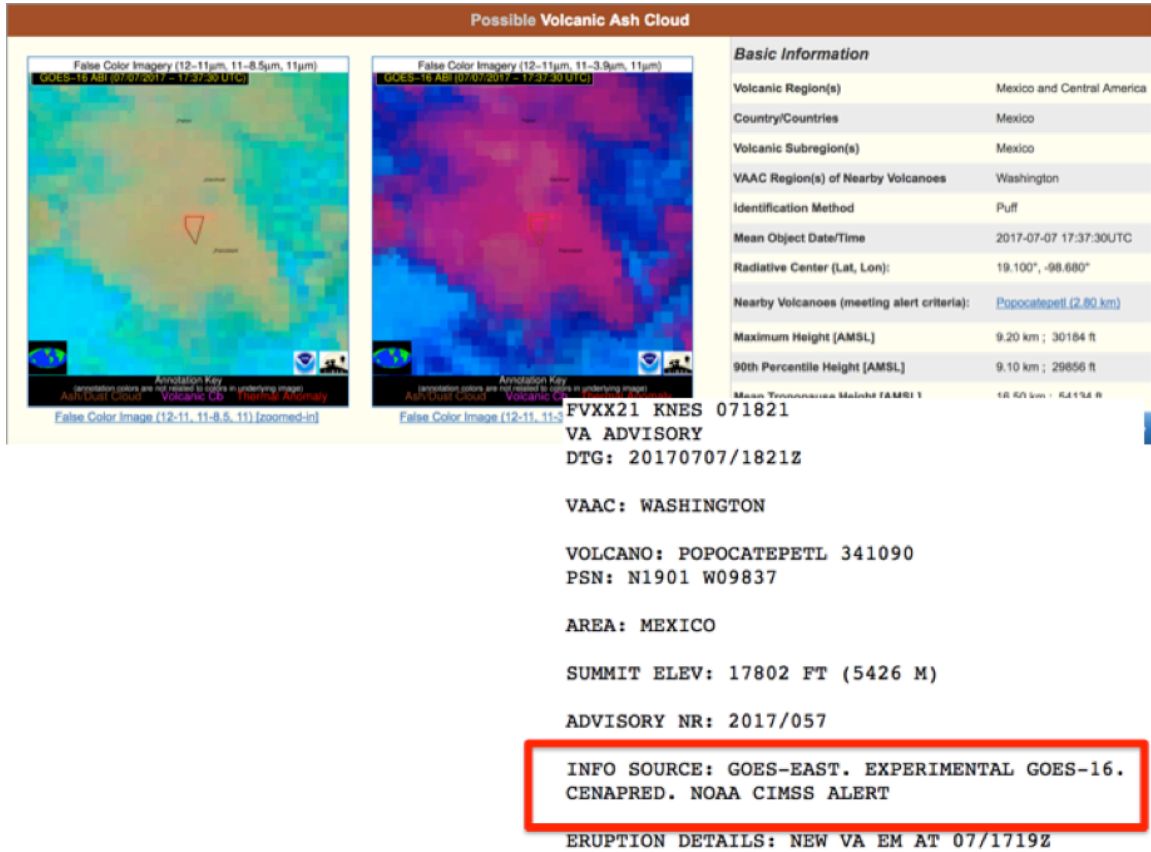

Figure 35. A GOES-16 VOLCAT alert for a Popocatepetl (Mexico) ash emission on July 7, 2017 is shown in the top panel. The volcanic ash advisory, issued by the Washington Volcanic Ash Advisory Center (VAAC), is also shown. This particular ash emission was not easily identifiable in GOES-13 or GOES-15 imagery. As indicated in the red box, this volcanic ash advisory was a direct result of the GOES-16 VOLCAT alert. This and many other cases illustrate the operational value of VOLCAT alerts and products. VOLCAT alerts are routinely cited by VAAC's.

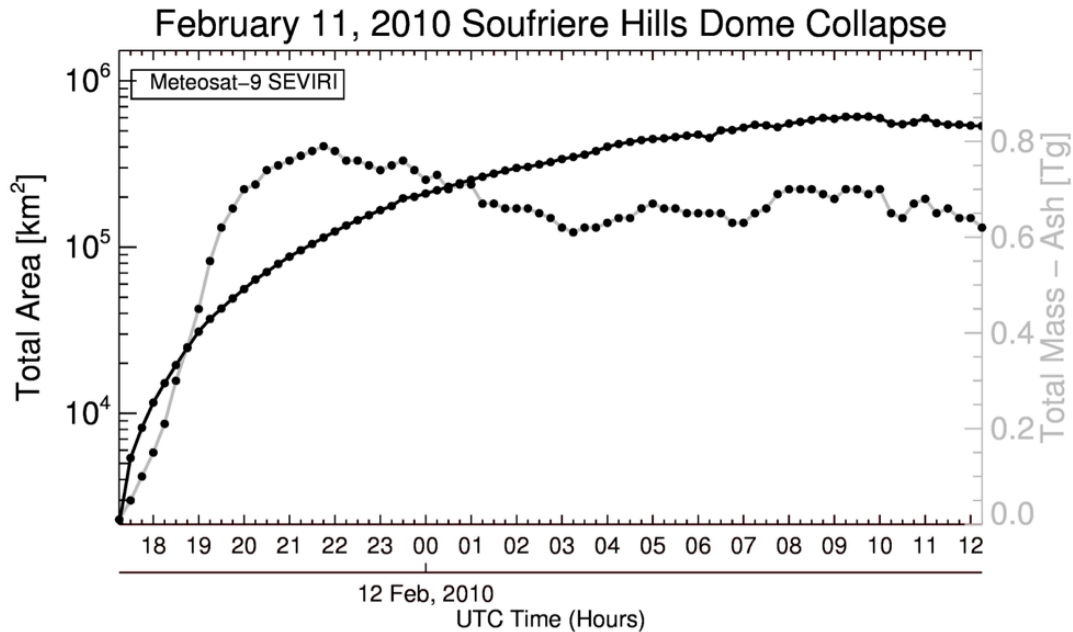

Figure 36. An automatically generated time series of total volcanic cloud area (black line) and total mass of ash (gray line) following the February 11, 2010 lava dome collapse at Soufriere Hills (Montserrat). The time series was derived from Meteosat Second Generation SEVIRI data, which has comparable capabilities as the GOES-R ABI (a GOES-16 ABI case is not shown because GOES-16 has not yet observed a significant explosive eruption). The time evolution of volcanic cloud area can be used to estimate mass eruption rate, which is a critical parameter needed to constrain dispersion models. The total mass of ash acts as an additional constraint. Automated derivation of time series, such as the one shown above, is a “one of a kind” capability.

### Publications and Conference Reports

Pavolonis, M. J., J. Sieglaff, and J. Cintineo (2015a), Spectrally Enhanced Cloud Objects (SECO): A Generalized Framework for Automated Detection of Volcanic Ash and Dust Clouds using Passive Satellite Measurements, Part I: Multispectral Analysis, *J. Geophys. Res. Atmos.*, 120, doi:[10.1002/2014JD022968](https://doi.org/10.1002/2014JD022968).

Pavolonis, M. J., J. Sieglaff, and J. Cintineo (2015b), Spectrally Enhanced Cloud Objects (SECO): A Generalized Framework for Automated Detection of Volcanic Ash and Dust Clouds using Passive Satellite Measurements, Part II: Cloud Object Analysis and Global Application, *J. Geophys. Res. Atmos.*, 120, doi:[10.1002/2014JD022969](https://doi.org/10.1002/2014JD022969).

Pavolonis, M. J., A. K. Heidinger, and J. Sieglaff (2013), Automated retrievals of volcanic ash and dust cloud properties from upwelling infrared measurements, *J. Geophys. Res. Atmos.*, 118, doi:[10.1002/jgrd.50173](https://doi.org/10.1002/jgrd.50173).

### References

Pavolonis, M. J., 2010: Advances in extracting cloud composition information from spaceborne infrared radiances: A robust alternative to brightness temperatures. Part I: Theory. *J. Applied Meteorology and Climatology*, 49, 1992-2012.



## **6.6 Development of GOES-R IR Clear-Sky and All-Sky Radiance Products for NCEP**

**CIMSS Task Leader: James A. Jung**

**CIMSS Support Scientist: Sharon Nebuda**

**NOAA Collaborators: Walter Wolf (NESDIS/STAR), Andrew Collard (NCEP/EMC)**

**Budget: \$72,000**

### **NOAA Long Term Goals:**

- Weather-Ready Nation

### **NOAA Strategic Goals:**

- Serve society's needs for weather and water

### **CIMSS Research Themes:**

- Satellite Meteorology Research and Applications
- Satellite Sensors and Techniques
- Environmental Models and Data Assimilation

### **Objective**

Determine the radiance data algorithm settings and quality control to optimize the product for data assimilation use.

### **Project Overview**

The GOES-16 ABI All Sky and Clear Sky Radiance (ASR/CSR) products are derived from the 2 km infrared pixels of channels 7-16 combined with the GOES-R cloud mask to identify clear and cloud impacted pixels. The full scene of 2 km pixels are subset into samples defined by a processing box to aid in the assignment of brightness temperatures, cloud amounts, and other information desired by NWP centers for quality control. This approach has been used by EUMETSAT for SEVIRI ASR/CSR products as well as JMA for AHI ASR/CSR products. Consistency of algorithm and data information from different geostationary imagers is desirable for NWP use in data assimilation.

To optimize the quality of the GOES-16 ABI ASR/CSR products, a validation effort is included in this project. The radiance product generation requires a selection of processing box size, data quality control, and metrics for NWP use in data assimilation. To evaluate the impact of these choices on the ASR/CSR product quality, the analysis from the NOAA/NCEP GFS Data Assimilation System (GDAS) has been used to provide collocated simulated brightness temperatures. By examining the differences between the GDAS brightness temperatures and the ABI ASR/CSR product, selection of the optimal settings for NWP use can be made. Also included in the effort is the validation of the radiance products using the Enterprise channel dependent cloud masks. Settings that are chosen for products using the GOES-R cloud mask will also be investigated for products generated using the Enterprise cloud masks.

### **Milestones with Summary of Accomplishments and Findings**

The first goal for this effort was to evaluate the software algorithm settings for the CSR product. To assess impact, GDAS collocated simulated brightness temperatures were collected for a 2-week period using 0, 6, 12, and 18Z full disk ABI images. Preliminary analysis began using data during July 2017. Development of software to read the ABI product within GDAS was completed and the GDAS simulated brightness temperatures were obtained. Once significant updates to the



GOES-16 products because available, 2 weeks of data were collected in November 2017 before GOES-16 was moved to its final GOES-East longitude.

Processing box size was the first setting examined. SEVIRI with 3 km infrared pixels and AHI with 2 km infrared pixels have radiance products generated using a 16x16 pixel processing box. A range of box sizes from 9x9 to 23x23 were applied to the CSR software. Results indicate small changes in defined brightness temperature performance for all infrared channels compared to the GDAS simulated values. Box size impact is shown for channel 14 (Figure 37). More significant than the departure statistics (observed-GDAS background/first guess) is the change in data count and file size. One important consideration is to select a box size with sufficient number of pixels in the sample to determine a box value for brightness temperature; a 16x16 box provides 256 pixels. Because the mean and standard deviation for the brightness temperature departures are not significantly different, the setting of 16x16 pixel processing box can be used for ABI with the benefit of remaining consistent with existing geostationary imager radiance products.

During the CSR analysis of the sample within the box, several parameters are calculated including percent clear pixels, percent valid pixels, standard deviation of the clear pixels, as well as the determination of clear pixels with values colder than 2 standard deviations from the mean. Percent clear in the box is the current metric provided with CSR products from SEVIRI and AHI. For ABI CSR product, the percent clear in the box will be used to determine that the sample size is sufficient to determine brightness temperature for the box. For NWP use, the standard deviation of the clear pixels will provide better information for quality control for data assimilation and has been selected for the ABI product.

Determining the brightness temperature for the sample of pixels is done using the mean value of the clear pixels for SEVIRI and AHI. For this project, the median value was also examined to see if its value was less impacted by cold pixels missed in cloud detection. For low values of clear pixel standard deviation of brightness temperature, the mean and median of the box sample is very similar. For large values of standard deviation, the median does have smaller bias (mean departure) when compared to the GDAS simulated brightness temperature. Additionally, to check for cloud impacted pixels missed by the cloud mask, an outlier screen will be added to remove pixels that are colder than 2 standard deviations from the clear pixel mean. This outlier check will reduce the impact of suspect data on the CSR product.

During the reporting period, the Enterprise cloud mask has been included in the analysis. Using the newer Enterprise cloud mask improves the CSR departure statistics through better cloud clearing. The number of processing boxes with lower clear pixel standard deviation of brightness temperature has also increased. This analysis is ongoing which will include examining the channel dependent cloud masks which will expand the clear sky extent for higher peaking channels.

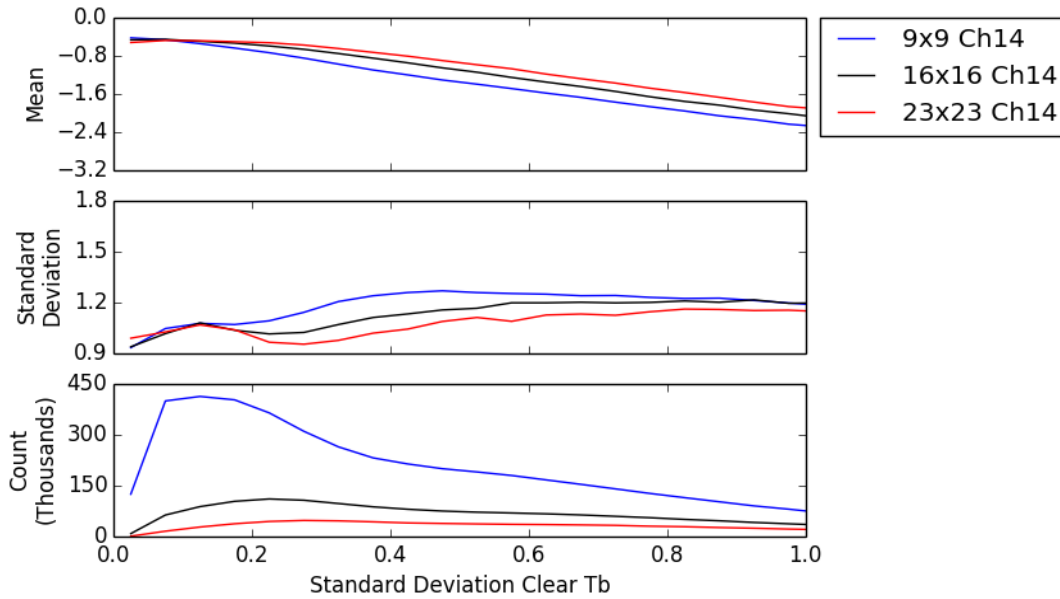

Figure 37. Departure statistics for channel 14, 11.2  $\mu\text{m}$  observed brightness temperature minus the GDAS simulated brightness temperature (first guess) as a function of the standard deviation of the clear pixels within the processing box. Data are limited to ocean points with sensor zenith angles less than 60°. Three processing box sizes are shown.

## 7. CIMSS Participation in the Development of GOES-R Proving Ground in 2017-2018

**CIMSS Task Leader:** Wayne Feltz

**CIMSS Support Scientists:** Chris Velden, Sarah Griffin, Scott Bachmeier, Scott Lindstrom, Lee Counce, Justin Sieglaff, Kaba Bah

**NOAA Collaborator(s):** Michael Pavolonis (NESDIS/STAR), Bradley Pierce (NESDIS/STAR), Andy Heidinger (NESDIS/STAR), and Tim Schmit (NESDIS/STAR)

**Budget:** \$310,000

### NOAA Long Term Goals:

- Weather-Ready Nation

### NOAA Strategic Goals:

- Serve society's needs for weather and water
- Support the nation's commerce with information for safe, efficient and environmentally sound transportation

### CIMSS Research Themes:

- Satellite Meteorology Research and Applications
- Satellite Sensors and Techniques
- Education and Outreach

### Objective

CIMSS researchers will expand partnerships with NWS Forecast Offices and NOAA National Centers to provide these products, train forecasters in their applications, and evaluate their utility.



This work will help to ensure that GOES-16 products will be available and useful to forecasters soon after launch.

### **Project Overview**

UW-CIMSS supported the GOES-16 Proving Ground demonstrations by evaluating the GOES-16/GOES-S Algorithm Working Group demonstration algorithms and baseline products, testing enhancements and advanced products (Risk Reduction), and providing user assessments and feedback to the product developers. Partnerships were expanded with NWS Forecast Offices in 2017-2018 to help train additional forecasters in product applications and to evaluate their utility. This work helped to ensure that GOES-16 products were available and useful to forecasters soon after launch.

In 2017-2018 research period of performance, the primary focus was to test, apply, and improve select GOES-16/GOES-17 satellite baseline, future capability, and risk reduction imagery/products in support of National Centers and local NWS offices. CIMSS researchers and scientists attended the June 2017 Proving Ground and User Readiness Satellite Science week in Kansas City, MO to determine goals/milestones of the GOES-16/GOES-S Risk Reduction and Proving Ground tasks and were present at regular by-monthly GOES-16/GOES-S Proving Ground coordination/reporting teleconferences. GOES-16/GOES-S PG oral and poster presentations occurred at various conferences in 2017-2018 including the American Meteorological Society (AMS) Conference, the National Weather Association (NWA) Conference, and the EUMETSAT Annual conference in Darmstadt, Germany.

### ***Test and Apply Algorithms for Expected GOES-16/GOES-S Satellite Data Imagery/products in Support of National NOAA Testbeds/PG Demonstrations***

The following Proving Ground activities occurred in 1 April 2017 – 30 March 2018 funding cycle where several GOES-16/GOES-S proxy decision support products developed at CIMSS were demonstrated with operational forecasters to obtain feedback:

- Hazardous Weather Testbed (HWT) Spring Experiment (19 June – 21 July 2017). Participants included 4 CIMSS researchers, 25 NWS forecasters, 5 Broadcast Meteorologists and several visiting scientists;
- National Hurricane Center (NHC) Tropical Cyclone Demonstration Participants included forecasters from NHC;
- Aviation Weather Center (AWC) Summer Experiment. Participants included AWC forecasters and FAA representatives;
- HPC/ OPC/ TAFB/ and SAB demonstrations (ongoing: focus on precipitation and ocean applications);
- High Latitude and Arctic Testbed (ongoing: focus on snow/ cloud/ volcanic ash/ and aviation applications). Participants include NWS Alaska Region;
- Air Quality (ongoing: focus on aerosol detection); and
- Pacific Region OCONUS Demonstration (ongoing: focus on tropical cyclones/ heavy rainfall/ and aviation applications). Participants include Jordan Gerth, NWS forecasters and scientists from the University of Hawaii.

UW-CIMSS scientists were engaged with the demonstrations listed above by providing the following GOES-16/GOES-S Baseline, Future Capability, or Risk Reduction decision support proxy data. Product assessment highlights for eight of the UW-CIMSS decision support products are listed below as reported in the GOES-16/GOES-S PG 2017 Annual report (to be published)





and HWT/AWC/NHC Testbed final evaluation reports located at: <http://www.goes-r.gov/users/proving-ground.html>

*UW-CIMSS Decision Support Product GOES-16/GOES-S Proving Ground Significant Outcomes and Product Assessment Highlights:*

1. **The Fog and Low Stratus products** - are currently scheduled to be operationalized on OSPO ESPC systems and will be delivered to NWS users via Satellite Broadcast Network (SBN), NCEP Central Region Operations (NCO) backbone, Direct Broadcast, and possibly AWIPS Data Distribution Service (DDS) as an alternative. This product was also delivered to the Alaska Aviation Weather Unit for testbed utility discussions. There is a current activity due to Proving Ground success to transition from research to operations.
2. **ProbSevere** - The NOAA/CIMSS ProbSevere model was evaluated in the HWT for the fifth consecutive year, with minor updates made since last year's experiment. The statistical model produces a probability that a developing storm will first produce any severe weather in the next 60 minutes but now contains specific severe weather type (wind, hail, and/or tornado). The data fusion product merges NWP-based instability and shear parameters, satellite vertical growth and glaciation rates, and radar derived maximum expected size of hail (MESH). A developing storm is tracked in both satellite and radar imagery using an object-oriented approach. As the storm matures, the NWP information and satellite growth trends are passed to the overlapping radar objects. The product updates approximately every two minutes and is displayed as contours that change color and thickness with probability to be overlaid on radar imagery. Data readout is available by mousing over the probability contour, revealing the probability of severe along with the model predictor values.
3. **GOES-R Legacy Atmospheric Profile Products** - New to the HWT this year were moisture and stability fields generated via a fusion of GOES Sounder radiance observations and Numerical Weather Prediction (NWP) forecast data using a GOES-16/GOES-S Risk Reduction (GOES-R3) algorithm.
4. **ABI Cloud Height Algorithm (ACHA)** - The Algorithm Working Group's Cloud Height Algorithms (ACHA), including the Cloud Top Height, Cloud Top Temperature, and Cloud Emissivity products, were provided to the AWC in 2012. Cloud Top Heights saw the most use, and as a result of forecaster feedback over the past two years, a Cloud Top Altitude product was developed for the 2014 demonstration. This product provides cloud tops in feet instead of meters, as feet (or flight levels) are the common unit in aviation forecasting. Multiple concepts for this product were explored in the 2015 demonstration and continued evaluation was requested. Additionally, the need for more ceiling and visibility specific products was noted. From this came the Cloud Cover Layers and the Cloud Base Heights in the 2016 demonstration. The latter of these two was evaluated in both experiments, while the Cloud Cover Layers was evaluated in only the Summer Experiment. The domain of both of these was focused on the CONUS and both were available in N- AWIPS and AWIPS-2 D2D.
5. **Atmospheric Motion Vectors (AMV)** - Satellite Derived Motion Winds or Atmospheric Motion Vectors, are wind vectors generated by tracking cloud features in visible, IR, and water vapor satellite imagery. The generation process utilizes three satellite images, the first and third to track the cloud feature, and the second to target the features themselves. Heights of these wind vectors are assigned based on 1) measured radiances of the targets and the spectral responses of the satellite and channel that is being sampled.
6. **Icing product** - Aircraft icing is a major hazard to aviation and no phase of aircraft operations is immune to the threat. This proposal addresses a high National Weather



Service (NWS) priority to improve the diagnosis of dangerous aircraft icing conditions for the aviation community. A capability to determine the in-flight icing (IFI) threat to aircraft has been developed that uses satellite derived cloud parameters. The methods are applicable to cloud parameters now commonly retrieved in real-time from meteorological satellite data, and are particularly well suited for application to the high spatial and temporal resolution operational cloud products from the GOES-R ABI. Verification studies indicate that relative to traditional icing forecasting techniques based on NWP analyses, the satellite methods significantly improve the resolution of icing conditions, including the dangerous conditions found to be associated with several recent aviation incidents and accidents. The objectives of this proposal are to (1) integrate a state of the art satellite based icing algorithm into the NOAA GOES-R Proving Ground (PG) processing system at the Cooperative Institute for Meteorological Satellite Studies (CIMSS), (2) validate and tune the algorithm, if necessary, using icing PIREPS as guidance, (3) generate and deliver satellite-based flight icing threat (S-FIT) products to the major NWS aviation weather forecast offices and to the PG with the current CIMSS product suite, (4) develop training materials for the S-FIT products, and (5) participate in and conduct S-FIT product evaluations to acquire feedback. The expected benefits to the NWS and the aviation community include better definition and situational awareness of the in-flight icing threat, improved icing forecasts, and the potential for safer, more efficient aviation.

7. **Legacy Atmospheric Profiling Product** - The algorithm retrieves atmospheric temperature and moisture profiles and the derived products including total precipitable water (TPW), layered precipitable water (PW), lifted index (LI), convective available potential energy (CAPE), total totals index (TT), Showalter index (SI), and the K-index (KI) from the clear sky infrared (IR) radiances. This project requires CIMSS scientists to develop and validate the GOES-R series LAP algorithm to be able to process high temporal and spatial resolution ABI data efficiently. This project provides prototype science codes to the GOES-R series algorithm integration team (AIT) for algorithm integration and helps the system provider to implement the algorithm and prototype codes into the GOES-R series ground system. CIMSS scientists also evaluate and validate the GOES-R series LAP products to assure that the GOES-R series legacy atmospheric temperature and moisture profiles, TPW, LI, CAPE, TT, SI and KI products meet the science/user requirements and operational applications.

1. *Fog and Low Stratus detection (Future Capability)*

***AWC input:***

Forecasters would like to keep this product in operations and also focus more on LIFR probabilities. Additionally, it is possible that an Aviation Weather Statement for C&V will be developed. During the Summer Experiment this was explored and the FLS was found to be a valuable tool here as well. It was requested that evaluation to this end be continued in future experiments.

Furthermore, forecasters would like to look more closely at a comparison of the MVFR, IFR, and LIFR probabilities to observed flight conditions, ceilings and visibilities. To this end, a qualitative view of the product has been designed as a web tool. Twenty of the major terminals that deal with ceiling issues on a regular basis have been input into the tool, with analysis of the past 24-hours available at 3-hour intervals.



## 2. *Probability of Severe Model*

### ***HWT input:***

The NOAA/CIMSS ProbSevere statistical model, planned for operational implementation by NCO as an update to MRMS in 2018, was evaluated in the HWT for the fifth consecutive year, with updates made since last year's experiment. ProbSevere is currently undergoing tuning and assessment with the in-orbit ABI and GLM data for future demonstrations. The statistical model produces a probability that a storm will first produce any severe weather in the next 60 minutes (Cintineo et al. 2014). The data fusion product merges RAP model-based instability and shear parameters, satellite vertical growth and glaciation rates, radar derived maximum expected size of hail (MESH), and Earth Networks (ENI) total lightning information. Additional RAP and Multi-Radar Multi-Sensor (MRMS) fields such as azimuthal shear were used in the model this year to provide guidance on specific severe hazards of tornado, wind, and hail. ProbSevere tracks a developing storm incorporating data from both satellite and radar imagery using an object-oriented approach. As the storm matures, the Numerical Weather Prediction (NWP) information, lightning data, and satellite growth trends are applied to the overlapping radar objects. The product updates approximately every two minutes and is displayed as contours with different colors and thicknesses corresponding to different probability value bins that are overlaid on radar imagery. Data readout is available by mousing over the probability contour, revealing the probability of severe for each hazard (hail, wind, and tornado), along with the model predictor values. The product was evaluated on its ability to increase forecaster confidence and skillfully extend lead time to severe hazards for NWS warnings during potential severe weather situations. Additionally, feedback regarding the product display and readout was solicited.

At the very least, ProbSevere enhanced forecaster confidence when issuing severe thunderstorm warnings, but played a lesser role for tornado warnings. On days when ProbSevere was used in warning decisions, forecasters felt that it increased their confidence in issuing severe thunderstorm warnings 88% of the time (37/42 answers), whereas they only felt that ProbTor increased their confidence in issuing tornado warnings 43% of the time (6/14 answers) when tornado warnings were issued. The small number of tornado cases during this experiment could have prevented a more robust evaluation of the ProbTor model. Forecasters noted that the trends in ProbSevere were the most important in focusing their attention on storms and adding confidence to the warnings. A quick jump in probabilities over a couple of radar volume scans was a key indicator to forecasters that the storm was intensifying rapidly and would most likely soon become severe. In these situations, forecasters recommended it was best to wait for one or two scans of rapidly increasing probabilities (e.g. from say 10% to 50% to 80%) and to interrogate the base data further before making a warning decision. 60% of the time, forecasters felt that ProbSevere increased their lead time for severe thunderstorm warning issuance, and felt that ProbTor increased lead time in tornado warning issuance 43% of the time. When asked after each shift if they would use ProbSevere in operations, 100% answered yes.

Many forecasters saw great utility in having the separate hazards and corresponding severe probabilities listed in the readout. An example from 22 June 2017 in eastern Colorado, shown below, shows how a forecaster found utility in using the different hazard percentages and how it affected their warning decision. ProbWind steadily increased from 1% to 73% over 20 minutes, which indicated an increasing damaging wind threat with the thunderstorms (in addition to hail). There is evidence in the radial velocity of accelerating outbound winds coincident with the time period that ProbWind increased. "Based on other environmental conditions", he decided that the



wind threat had increased from 60 mph to 70 mph and incorporated this into his warning. Later on, wind damage was reported with this storm, although the wind speed was unknown.

This example shows the utility the specific ProbSevere hazards can have in a warning environment.

### ***Limitations of ProbSevere***

There were still some instances commonly pointed out by forecasters where ProbSevere was not effective. Forecasters often found that the ProbSevere probabilities often lagged slightly behind the strengthening in base radar data both spatially and temporally due to the latency of the MRMS data processing and subsequent ingesting into the model. In rapidly strengthening scenarios this seemed to hamper the lead time of ProbSevere compared to that of the base radar data. Also, when storms were within close proximity of each other, the ProbSevere model would typically group the storms together into one contour, often times reducing the severe probability value drastically and making ProbSevere much less useful and trustworthy. Some ideas offered from forecasters included an option to have a user defined box drawn around a storm of interest and use that to track storms, or to possibly have a user-defined reflectivity threshold to follow the storm core more effectively.

“Found that as storms morphed, got bigger, the ProbSevere became one big contour. That was frustrating when looking at ProbTor because one storm area had 3 circulations (few counties apart) and only one ProbTor. Maybe a user defined (drawn the box you want) option for ProbSevere/Tor would help.”

*Forecaster, End-of-Week Survey*

“ProbSevere and ProbTor are useful for situational awareness; however, there is some lag from base data because of the use of MRMS. Though it probably isn't feasible from a bandwidth standpoint, I could see a significant advantage of incorporating data from individual radars.”

*Forecaster, End-of-Week Survey*

As has been the case in previous years of the HWT experiment, ProbSevere was most useful in cases where severe hail was the primary threat and in discrete storm modes. This is to be expected as there is no other input for wind or tornado that performs as well as MESH does for hail guidance. Many forecasters did comment that this iteration of ProbSevere seemed to do better with wind and tornado events than previous versions, but could still use some further improvements before being ready for use in primetime in operations. Many of the issues with the ProbWind seemed to stem from storm tracking issues and the significant wind being displaced from the reflectivity core, such as in cases of outflows racing out ahead of the storm. Forecasters also commented that the model could be better trained for different regions of the country with different environments and threats than others.

### **3. Legacy Temperature and Moisture Profile - Nearcast Atmospheric Stability Indices (Risk Reduction)**

#### ***HWT input:***

The enhanced NearCast analyses and short-range forecasts were the primary ways that forecasters used the GOES Moisture and Temperature soundings in their forecasting process. Without the NearCasts, forecasters would have been unlikely to use the GOES retrievals as stand-alone observations. The NearCast products were especially effective in increasing situational awareness to where convection was more and less likely to initiate in the 0-6 hour range and how on-going



convection was likely to evolve. The training was certainly an important part of this success, as it focused on what features to look for in the NearCast fields via multiple examples. The theta-e difference instability field was very well-received by the forecasters, garnering an average rating of 4.41 out of 5 from participants when asked how useful its addition would be to their forecast office. Finally, although the data gaps were undesirable, participants understood why they occurred and didn't let that deter them from using the NearCast products due to the valuable and unique information they provide in areas where GOES data have recently been available.

***AWC input:***

The CWSU forecasters were particularly pleased with this product. While they noted that the concept of the NearCast required a bit of a learning curve, they liked the fact that the color bar made it very easy to interpret, in this case the dry air associated with the trough sinking into the middle of the country as compared to the higher instabilities associated with the obvious frontal features of the low. All of the CWSU offices in attendance requested the weblink for the imagery as it is not currently available in their AWIPS

**4. *ACHA Cloud products - (Baseline)***

***AWC Input:***

Estimating cloud bases is a challenging prospect given the lack of information in the satellite observations for some cloud types. How they are derived is therefore highly dependent upon the cloud type. The method is to first derive the cloud top height from ACHA and then to derive the geometrical thickness of the cloud layer. The cloud base height (CBH) is computed as the difference between the two. For cirrus and low-level water cloud, a direct estimation of the cloud geometrical thickness is possible from the satellite observations. For moderately thick clouds throughout the atmosphere, a set of regressions derived from CloudSat are used. Both the direct retrieval and CloudSat regressions use (1) the estimated cloud top, and (2) an estimated cloud layer thickness from cloud optical depth, cloud from GOES generated statistics. For the thickest clouds, the satellite observations provide little skill and the CCL Level from the NWP ancillary data is used to estimate the geometrical thickness. However, it is often the case that there are multiple layers of clouds which overlap. In these cases, the derived base is most indicative of that for the highest cloud layer. Treatment of these cases is being actively researched. The Cloud Base Heights were first evaluated in the 2016 Winter Experiment for the C&V effort. As mentioned in earlier sections, one of the major foci of the AWT experiments this year has been the Digital Aviation Services efforts and associated grid editing through GFE. The Winter Experiment was the first deep dive into this process and such was mainly an exercise in knobology. However, a cursory evaluation was done of the Cloud Base Height (hereafter referred to as CBH) product. The initial observation of this product by many forecasters was its high accuracy in single layer clouds. However, it did also have a marked struggled in areas multiple cloud layers. In those multiple layers, the bases were far too high, and it appeared the algorithm was estimating the base of the top most layer of clouds when compared to visible imagery.

**5. *Atmospheric Motion Vectors product - (Baseline)***

***AWC Input:***

One of the main concepts for the AMVs taken from last year was the possibility of utilizing them to aid in the forecast or verification of compression issues around major terminals. Compression is caused when the winds at upper levels are much higher than winds near the surface. As arrivals near the terminal, these stronger upper level winds cause aircraft to quickly catch up with those at lower levels in lighter winds. It is the opposite on take off if there are strong surface winds and lighter winds aloft. Because of the minimum distance requirements between aircraft, traffic flow managers are required to spread traffic out further in these cases and often end up having to delay



or hold other flights. O’Hare and the New York area terminals are those where compression is a common issue and causes the biggest problems.

In 2016 the AWC began producing forecasts of vertical winds using the SREF, the idea being to provide traffic flow managers a forecast vertical profile of winds. However, this would not be limited to just the terminal point. The arrival and departure points of each terminal contain an expansive chunk of airspace and wind conditions and differ from one end to the other. Therefore, plots from the various approach and departure gates around the main hubs are also created. The first airport this has been explored for is ORD.

This is a very new concept and currently these plots are being verified using aircraft sounds and also RAOBs. The latter are typically only available at the center of the main hub and not at the various departure/arrival points. Additionally, aircraft soundings can be limited at times as they are only produced from certain types of aircraft.

It is here where AMVs could perhaps become useful. While AMVs are derived only for cloud objects in the top layer of clouds, the addition of many spectral channels from which winds can be derived will increase the density of winds in these layers. The layers themselves will not be consistent to a specific point, but by examining winds from various points within a region, forecasters may be able to get a better perspective on the vertical profile of winds. These could be compared to SREF wind forecast departure/arrival points as well as RAOBs and RAOB sounds to potentially 1) provide at least some wind forecast verification, 2) provide more insight on the accuracy and reliability of satellite derived winds, and 3) gauge whether satellite derived winds provide any information over and above current modeled winds.

## 6. *Icing*

### *AWC Input:*

The Flight Icing Threat (FIT) integrates various cloud properties from the GOES-R baseline DCOMP algorithm to generate a probability and intensity of icing conditions. It is composed of three components including (1) an icing mask available day and night which discriminates regions of possible icing, (2) an icing probability, estimated during the daytime only, and (3) a two-category intensity index which is also derived during the daytime only. While it is difficult to validate a product such as this given the lack of icing PIREPs and other methods of ice measurement, it has been shown to have skill in identifying areas of more significant icing conditions.

Funding to continue work on this algorithm was received in late 2015. As such, it was evaluated during Evaluation Period I of the 2017 GOES-R/JPSS Demonstration, and underwent an in detail examination during the Winter Experiment. Prior to this, several improvements had already been made after the 2016 GOES-R/JPSS demonstration. These included the addition of a ‘heavy’ category to identify the more intense icing associated with supercooled large droplets and convection, as well as improved estimates of cloud vertical structure that enable the inference of icing conditions embedded beneath glaciated clouds. Additionally, this year’s evaluation was expanded to include an AWIPS-2 version of the product, which was examined by forecasters in D2D.

In general, forecasters continue to note that the FIT has a lot of potential. It provides situational awareness not typically available for icing conditions, typically in areas that don’t see a lot of in situ icing reports from aircraft. This is beneficial both to G-AIRMET and SIGMET issuances. The product was also found useful in the non-convective CAWS portion of the Winter



Experiment. While a non-convective CAWS is not likely to be made an operationally issued product, the concept explored the need for a product that would fit in between a G-AIRMET and a SIGMET, similar to what is currently issued at the Alaskan Aviation Weather Unit. This ‘in-between’ product would identify icing areas not as broad as the forecasted moderate or greater conditions in a G-AIRMET, but less specific than the severe conditions within a SIGMET or ‘warning’ product.

Its ability to discern icing intensities (during the day only) within the clouds helped to narrow down smaller areas in which a non-convective CAWS may need to be issued. In some cases of widespread clouds of multiple layers, the FIT product is more uncertain and it became somewhat difficult to determine which particular areas to really key in on. While this ‘messiness’ depicted the inherent nature of multi-layer clouds, forecasters mentioned that it might be helpful to apply some sort of smoothing technique in some cases as N-AWIPS does not current support this capability. AWIPS-2 D2D, however, does provide the ability to interpolate, and forecasters were able to utilize this if they chose.

While the algorithm did show continued improvement over the past few years, there were still a few caveats forecasters noted. Firstly, intensities were overestimated in the terminator region. Low sun angles and the shift from day to nighttime retrievals were the culprits behind this issue. Eclipse periods were also somewhat problematic. With the stray light during these periods, there was a significant erroneous increase in intensities. This occurred at relatively the same time each day and so was easy become accustomed to. Additionally, there were some cases in which undetected thin cirrus clouds overlapping liquid clouds were interpreted as SLD causing an overestimation of the icing threat. Lastly, thin cirrus over snow covered ground also caused overestimation at times. All of these caveats –terminator regions, eclipse periods, and cirrus cloud contamination- were significant, but with a good understanding of the cloud environment, not particularly difficult for forecasters to become accustomed to and subsequently keep in mind when issuing icing forecasts.

Beyond the non-convective CAWS, there were a number of CWSUs who noted the potential benefit of the product in their operations. CWSUs advise the traffic flow managers within their air space of various weather hazards that may impact air traffic. Icing is not typically one of the highest priority issues to forecast for in their daily duties, however it was suggested that the FIT would become useful in and around a major terminal, particularly the top and base of the icing layer. Icing is commonly seen in the ascent or descent phase of flight as a layer of clouds conducive to icing settles over a particular hub. Identifying the extent of the icing layer within these clouds as well as the estimated intensity of icing with the FIT would provide valuable situational awareness. There were several cases where the FIT showed high skill in identifying smaller scale areas of icing around terminals that would have provided this situational awareness.

## **7. GOES-16/GOES-S Legacy Atmospheric Profiling Products - (Baseline)**

### ***HWT Input:***

The GOES Sounder LAP products were viewed most often by forecasters at the beginning of the shift as they conducted their initial environmental analysis. Additionally, some forecasters viewed the products throughout the shift to get an update on how moisture and instability were evolving. Oftentimes they would use the LAP information as a check on the models and other environmental information (SPC meso-analysis, NUCAPS, etc). Participants liked the full-CONUS coverage of these environmental fields. Past product demonstrations have revealed that a portion of forecasters prefer fields with little-to-no data gaps, even if that means filling in the gaps with NWP data. In addition to the complete spatial coverage, the hourly availability and



low-latency of the LAP products were appreciated, keeping forecasters aware of significant environmental trends as they occurred.

Participants consistently commented that gradients, maxima/minima, and trends in the LAP fields provided them with the most unique and accurate information, rather than the absolute values themselves. It was along the moisture/instability gradients and within the areas of increasing moisture/instability that convection most often developed. Alternatively, decreasing moisture/instability trends were often a sign that convective activity would cease. Forecasters would look back at the fields at the end of the day and see that convection had indeed developed along the gradients and in areas of increasing moisture/instability. Observing this early in the week gave forecasters confidence when using the tools as the week progressed. Additional forecast situations in which the LAP products aided participants included: dryline progression, depth of moisture in the atmosphere, progression of moisture return, elevated or surface-based storms, severe vs. non-severe storms, and convection in data sparse regions.

While the PW values appeared to be reasonably consistent with that from other data sources (e.g., Rapid Refresh Model, SPC meso-analysis, radiosondes), the LAP CAPE absolute values were often substantially different. This led participants to lose trust in the absolute values of the LAP CAPE field, which is the instability field of choice for most operational forecasters. The other major issue with the LAP products was the apparent “blotchiness” and unrealistic spatial variations that oftentimes appeared in the fields. This anomaly was addressed and mostly resolved by the developers after week 3, but deficiencies in the Sounder instrument cause some striping to remain.

### ***Development of New GOES-R Weather Event Simulations and AWIPS-II Transition Support***

CIMSS remains committed to assuring a smooth transition of all CIMSS research to operations products from the existing AWIPS software to the upcoming AWIPS-II. Preliminary work has been done finding a new product implementation approach for AWIPS-II. AWIPS-II activities are rapidly accelerating on the national scale to transition local applications between the two software environments. An AWIPS archive capable of archiving 60 days worth of AWIPS formatted files has been acquired through SSEC funding to support easier generation of WES cases AWIPS-II will soon be accessible for use at CIMSS, with training modules employing the new AWIPS software included as part of the VISIT/COMET training programs for operational satellite meteorology professional development. UW-CIMSS participated in multiple GOES-16/GOES-S Proving Ground organizational and testbed/PG demonstration planning telecons.

### **Publications**

Cintineo, Rebecca M.; Otkin, Jason A.; Jones, Thomas A.; Koch, Steven and Stensrud, David J.. **Assimilation of synthetic GOES-R ABI infrared brightness temperatures and WSR-88D radar observations in a high-resolution OSSE.** *Monthly Weather Review*, Volume 144, Issue 9, 2016, pp.3159-3180. Reprint # 7698

Feng, Lian; Hu, Chuanmin; Barnes, Brian B.; Mannino, Antonio; Heidinger, Andrew K.; Strabala, Kathleen and Iraci, Laura T.. **Cloud and sun-glint statistics derived from GOES and MODIS observations over the Intra-Americas Sea for GEO-CAPE mission planning.** *Journal of Geophysical Research-Atmospheres*, Volume: 122, Issue: 3, 2017, pp.1725-1745. Reprint # 7878.





Gravelle, Chad M.; Mecikalski, John R.; Line, William E.; Bedka, Kristopher M.; Petersen, Ralph A.; Sieglaff, Justin M.; Stano, Geoffrey T. and Goodman, Steven J.. **Demonstration of a GOES-R satellite convective toolkit to 'bridge the gap' between severe weather watches and warnings: An example from the 20 May 2013 Moore, Oklahoma, tornado outbreak.** *Bulletin of the American Meteorological Society*, Volume 97, Issue 1, 2016, pp.69-84. Reprint # 7564.

Greenwald, Thomas J.; Pierce, R. Bradley; Schaack, Todd; Otkin, Jason; Rogal, Marek; Bah, Kaba; Lenzen, Allen; Nelson, Jim; Li, Jun and Huang, Hung-Lung. **Real-time simulation of the GOES-R ABI for user readiness and product evaluation.** *Bulletin of the American Meteorological Society*, Volume 97, Issue 2, 2016, pp.245-261. Reprint # 7570.

Gunshor, Mathew. **GOES-R: What's new in orbit.** *AWPA Reporter*, Volume: 85, Issue: 1, 2018, pp.57-59. Reprint # 8230.

Lindstrom, Scott; Schmit, Timothy J.; Gunshor, Mathew M.; Daniels, Jaime; Bah, Kaba and Goodman, Steven J.. **Latest assessment of GOES-R (16) Advanced Baseline Imager (ABI) data quality from an application and training perspective.** Piscataway, NJ, Institute of Electrical and Electronic Engineers, Inc. (IEEE), 2017, pp.283-285. Reprint # 8238.

Line, William E.; Schmit, Timothy J.; Lindsey, Daniel T. and Goodman, Steven J.. **Use of geostationary super rapid scan satellite imagery by the Storm Prediction Center.** *Weather and Forecasting*, Volume 31, Issue 4, 2016, pp.483-494. Reprint # 7587.

Miller, Steven D.; Schmit, Timothy; Seaman, Curtis J.; Lindsey, Daniel T.; Gunshor, Mathew M.; Kohrs, Richard A.; Sumida, Yasuhiko and Hillger, Donald. **A sight for sore eyes: The return of true color to geostationary satellites.** *Bulletin of the American Meteorological Society*, Volume 97, Issue 10, 2016, pp.1803-1816. Reprint # 7780.

Rabin, Robert M.; Gultepe, Ismail; Kuligowski, Robert J. and Heidinger, Andrew K.. **Monitoring snow using geostationary satellite retrievals during the SAAWSO Project.** *Pure and Applied Geophysics*, Volume 173, Issue 9, 2016, pp.3085-3102. Reprint # 7732.

Schmit, Timothy J.; Griffith, Paul; Gunshor, Mathew M.; Daniels, Jaime M.; Goodman, Steven J. and Lebair, William J.. **A closer look at the ABI on the GOES-R series.** *Bulletin of the American Meteorological Society*, Volume: 98, Issue: 4, 2017, pp.681-698. Reprint # 7913.

Schmit, Timothy J.; Griffith, Paul; Gunshor, Mathew M.; Daniels, Jaime M.; Goodman, Steven J. and Lebair, William J.. **A closer look at the ABI on the GOES-R series: Supplement.** *Bulletin of the American Meteorological Society*, Volume: 98, Issue: 4, 2017. Reprint # 7913.

## **8. CIMSS Collaboration with the NWS Operations Proving Ground**

**CIMSS Task Leader: Chad Gravelle**  
**CIMSS Support Scientist: Wayne Feltz**  
**NOAA Collaborator: Tim Schmit**  
**Budget: \$172,000**

### **NOAA Long Term Goals:**

- Weather-Ready Nation



### **NOAA Strategic Goals:**

- Serve society's needs for weather and water
- Support the nation's commerce with information for safe, efficient and environmentally sound transportation
- Provide critical support for the NOAA mission

### **CIMSS Research Themes:**

- Satellite Meteorology Research and Applications
- Satellite Sensors and Techniques
- Education and Outreach

### **Objective**

The CIMSS collaboration with the NWS Operations Proving Ground focuses on maximizing analysis and forecast value of geostationary satellite data and products, particularly activities centered on NWS weather forecast office operations to improve forecast and warning services to the nation.

### **Project Overview**

This project entails activities focused on interactions with NWS forecasters at weather forecast offices to prepare them for new satellite dependent products that will become operational after the launch of the GOES-R satellite series.

### **Milestones with Summary of Accomplishments and Findings**

The following are recent milestones and accomplishments:

- Manuscript submitted to the American Meteorological Society's Weather, Analysis & Forecasting journal titled "Forecaster Evaluations of High-Temporal Satellite Imagery for the GOES-R Era at the NWS Operations Proving Ground";
- Operations Proving Ground evaluation on operational applications of multispectral bands for the GOES-R era was coordinated and facilitated; and
- NWS Central and Eastern Region evaluation on the CIMSS ProbSevere Model is currently being coordinated and facilitated.

### **Publications and Conference Reports**

Gravelle, C. M., J. R. Mecikalski, W. E. Line, K. M. Bedka, R. A. Petersen, J.M. Sieglaff, G. T. Stano, and S. J. Goodman, 2016: Demonstration of a GOES-R satellite convective toolkit to "bridge the gap" between severe weather watches and warnings: An example from the 20 May 2013 Moore, Oklahoma, tornado outbreak. *Bull. Amer. Meteor. Soc.*, **97**, 69–84, doi:10.1175/BAMS-D-14-00054.1.

Gravelle, C. M., K. J. Runk, K. L. Crandall, and D. W. Snyder, 2016: Forecaster evaluations of high-temporal satellite imagery for the GOES-R era at the NWS Operations Proving Ground. *Wea. Forecasting*, In Press.

43<sup>rd</sup> American Meteorological Society Conference on Broadcast Meteorology. Raleigh, NC. *GOES-R Derived Products for Operational Meteorology*. 9 June 2015.

2015 Satellite Proving Ground/User Readiness Meeting. Kansas City, MO. *Preliminary Results from the Operations Proving Ground 1-minute Satellite Imagery Evaluation*. 17 June 2015.



2015 COMET Mesoscale Analysis and Prediction (COMAP) Course. Boulder, CO. *Capabilities of The Next-Generation Geostationary Environmental Satellite System for Operational Meteorology*. 17 July 2015.

2015 High Plains Conference. Goodland, KS. *Capabilities of The Next-Generation Geostationary Environmental Satellite System for Operational Meteorology*. 12 August 2015.

2016 American Meteorological Society Annual Meeting. New Orleans, LA. *Enhancing Impact-Based Decision Support Services in the GOES-R Era*. 13 January 2016.

St. Louis, MO AMS Chapter Local Meeting. *Capabilities of The Next-Generation Geostationary Environmental Satellite System for Operational Meteorology*. St. Louis, MO. 18 February 2016.

St. Louis, MO NWS Forecast Office Visit. St. Louis, MO. 19 February 2016.

Douglas County, KS Emergency Management Severe Weather Symposium. Lawrence, KS. *Observing the Initiation and Development of Convection in the GOES-R Era*. 5 March 2016.

## **9. CIMSS Support for High Impact Weather Studies with GOES-16 ABI and JPSS Advanced IR Sounder Data**

**CIMSS Task Leader: Jun Li**

**CIMSS Support Scientists: Kevin Baggett, Jinlong Li, Agnes Lim, Pei Wang**

**NOAA Collaborator: Timothy J. Schmit**

**Budget: \$175,000**

### **NOAA Long Term Goals:**

- Weather-Ready Nation
- Resilient Coastal Communities and Economies

### **NOAA Strategic Goals:**

- Serve society's needs for weather and water
- Provide critical support for the NOAA mission

### **CIMSS Research Themes:**

- Satellite Meteorology Research and Applications
- Environmental Models and Data Assimilation

### **Objective**

The primary goal of CIMSS high impact weather (HIW) project is to study the applications of high spatial and temporal resolution water vapor information from GOES-R series on improving severe storm warning and short-range forecasts.

### **Project Overview**

To take advantage of high vertical resolution information, advanced infrared sounder measurements from polar-orbiting satellites (JPSS series) are used together with GOES-R series water vapor information for HIW warning and forecasting. Focuses are on: (1) how to better use of high temporal and spatial resolution GOES-R series water vapor information in pre-convection environment for severe storm warning, and (2) how to improve severe storm over CONUS and tropical cyclones (TCs) such as Sandy (2012), Harvey (2017), Irma (2017) and Maria (2017) with



high temporal and spatial resolution GOES-R series water vapor information in regional and storm scale numerical weather prediction (NWP) models?

The objectives of this CIMSS high impact weather (HIW) studies are:

1. To improve the high impact weather (HIW) forecasts with high temporal and spatial resolution GOES-R series water vapor measurements. High temporal resolution moisture measurements from the Advanced Baseline Imager (ABI) onboard GOES-16, the first satellite of GOES-R series, launched on 19 November 2016, the current GOES Sounder, and the Advanced Himawari Imager (AHI) onboard Himawari-8 are used for HIW short-range forecasting through data assimilation in regional and storm scale numerical weather prediction (NWP) models.
2. To study value-added advanced IR sounder measurements from polar-orbit satellites (POES) for HIW warning, nowcasting and short-range forecasting, and to demonstrate the advantage of combined ABI and CrIS/AIRS/IASI measurements in HIW nowcasting and short-range forecasting. Study the application of atmospheric moisture and instability information from the combined POES/GOES-16 measurements in pre-convection environment for warning and forecasting; improve short-range severe storm forecasts through assimilation of combined ABI and advanced IR sounders observations.

Local severe storm (LSS) and hurricane/typhoon cases will be used in this study. Weather Research and Forecasting (WRF) and operational hurricane WRF (HWRF) models are used together with community based data assimilation system - Gridpoint Statistical Interpolation (GSI) in our studies. The research progress will be demonstrated in CIMSS near real time (NRT) Satellite Data Assimilation for Tropical storm forecasts (SDAT) (<http://cimss.ssec.wisc.edu/sdat>). On one hand, SDAT serves as research testbed to conduct HIW studies that have the potential transition to operation; on the other hand, SDAT directly provides forecast products in NRT to users for forecast applications.

CIMSS HIW project is highly related to reliable and stable forecasts on super storm such as hurricane Sandy (2012) landed on CONUS, hurricane Matthew (2016) affected the east coast, Hurricane Harvey, Irma and Maria in 2017. Continuous observations of atmospheric moisture information in environment are very important to the prediction of the genesis, intensification, motion, rainfall potential, and landing impacts of storms through NWP models. ABI provides water vapor information with much better spatial coverage and higher temporal/spatial resolution than the current GOES Sounder. With GOES-16 launched on 19 November 2016 and ABI data available in 2017, a dedicated research towards operational application of ABI water vapor measurements for severe storm events is needed to optimize the information extraction, data assimilation and utilizations within a higher resolution regional NWP framework. The advantages of using ABI observations for regional NWP are that (a) the data have good temporal coverage to assure the data availability within each assimilation time window; (b) the assimilation window can be narrowed (i.e., within  $\pm 0.5$  hour) in order to keep consistency between model's atmospheric states and the observations in a rapid changing weather situation; and (c) more frequent assimilation of data (i.e., hourly assimilation instead of 6-hourly assimilation) is possible.



## Milestones with Summary of Accomplishments and Findings

### ***CIMSS near real-time (NRT) Satellite Data Assimilation for Tropical storm (SDAT) system has been used for demonstrating the impact of JPSS and GOES-R series measurements***

CIMSS scientists have developed a NRT regional SDAT (<http://cimss.ssec.wisc.edu/sdat>) utilizing the NESDIS-funded Supercomputer S4 (Boukabara et al. 2016) physically located at SSEC. The core of the SDAT system is the NOAA community GSI assimilation system and the advanced WRF model. Real-time NCEP GFS outputs are used as SDAT background and initial/boundary input. The system runs a 6-hour cycling assimilation followed by 72-hour forecasts that could be extended to 120 hours if computer resources allow. In addition to conventional data and satellite radiances obtained from NCEP BUFR files which contain GOES Sounder, AMSU-A/-B, HIRS, MHS, ATMS, AIRS, CrIS and IASI are assimilated, the system is also capable of assimilating satellite derived products such as CrIS cloud-cleared radiances (CCRs) (or cloud-removed radiances), derived soundings, ABI derived AMVs, total precipitable water (TPW), and layered precipitable water (LPW). Therefore, SDAT is flexible for assimilating JPSS/GOES-R series radiances and products. Using SDAT as a research testbed, we have conducted studies to improve the assimilation of CrIS radiances by using collocated high resolution VIIRS data (e.g., cloud mask and IR band radiances) to better handle sub-footprint clouds as follows:

- (a) Using collocated VIIRS cloud mask information to characterize CrIS sounder sub-footprint cloudiness, so that CrIS clear fields-of-view (FOVs) and clear channels (not affected by clouds) can be confidently assimilated.
- (b) Using cloud-clearing technique (Li et al. 2005) developed by CIMSS scientists, CrIS cloud-cleared radiances can be derived from collocated CrIS cloudy radiances and high resolution VIIRS IR band clear radiances. The CrIS CCRs allow assimilation of thermodynamic information from those footprints with partial cloud cover. The improved impact from assimilating CrIS CCRs has been demonstrated under joint support of JPSS PGR and this high impact weather projects (Wang et al. 2017), and the progress is highlighted by Editor for AGU news: <https://eos.org/editor-highlights/listening-to-the-clouds>

Figure 38 shows impact of CrIS CCRs on hurricane Joaquin (2015) forecasts with SDAT. Results show that for some situations the CrIS CCRs provided critical needed observations in cloudy skies for improving track and intensity forecasts. Results show the seven groups of the forecasts (120-hour) after satellite sounder data assimilation, it can be seen that consistent improvement from using CrIS CCRs is obtained.



## Hurricane Joaquin Track Forecast

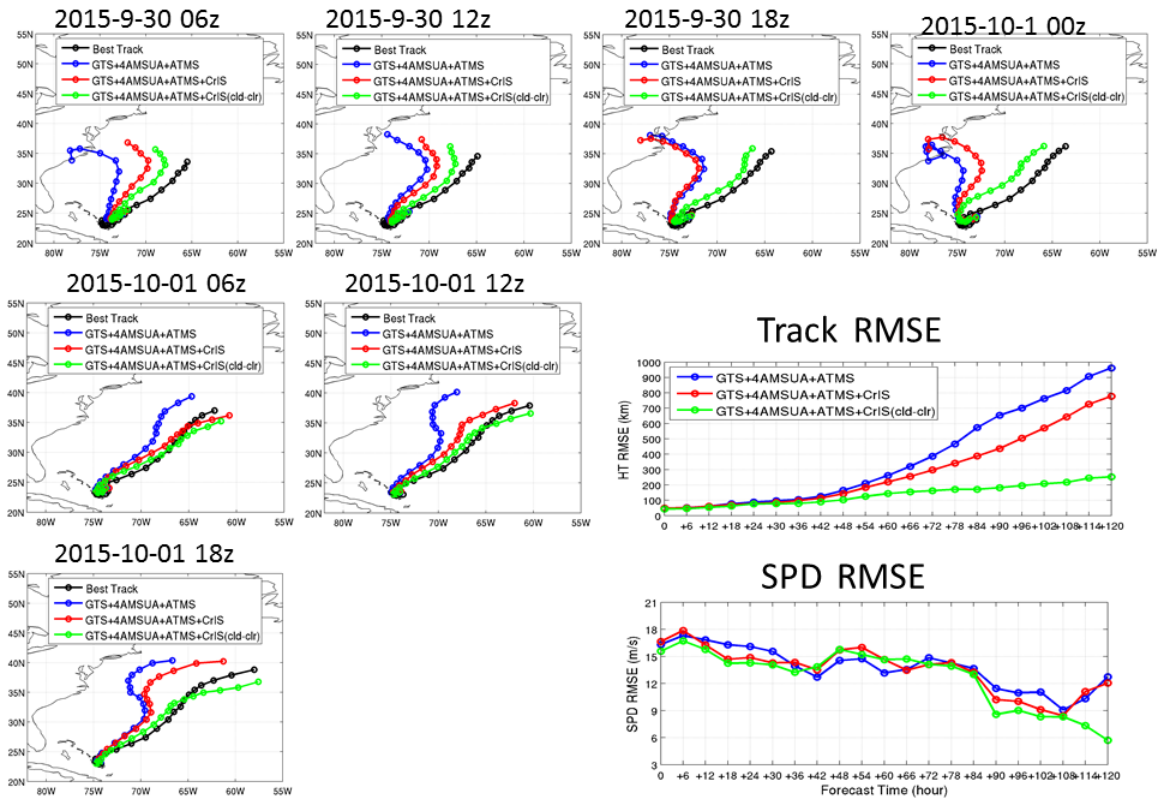
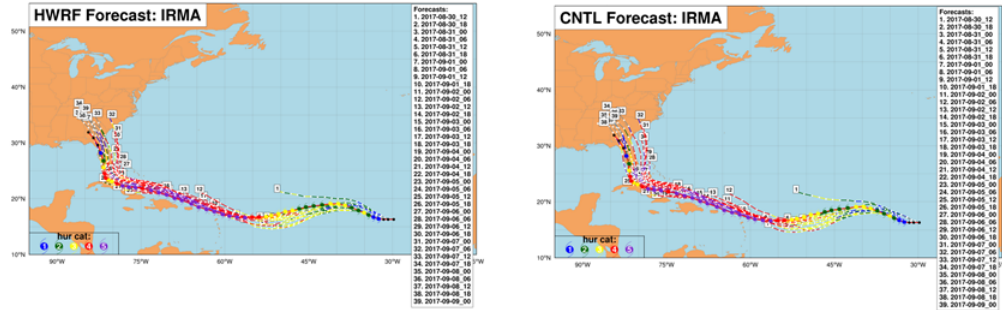

Figure 38. Seven groups of the 120-hour forecasts for Hurricane Joaquin (2015) after assimilation of CrIS CCRs. Black: best estimate (observations); Bule: using conventional data from GTS, 4 AMSU-A and ATMs; Red: conventional data, 4 AMSU-A, ATMS and CrIS clear radiances (GSI approach); green: same as red but using CrIS CCRs instead of CrIS clear radiances only.

### **Latest version of HWRF benchmarked at S4 to support JPSS and GOES-R series data assimilation research**

In order to support JPSS and GOES-R series data assimilation for high impact weather forecast improvement in the NOAA operational NWP models, the latest version of the operational HWRF model has been tested at S4. The community HWRF\_v3.9a from DTC was installed on S4 in November 2017 and tested with Hurricane Irma (2017) (including DA with hybrid GSI). Figure 39 shows the forecasts from control (HWRF/S4) and NOAA operational HWRF (HWRF/Op), for track and categories. The forecasts between HWRF/S4 and HWRF/Op are similar. The RMSE (root mean square error) statistics for track and maximum wind speed forecasts are also reasonably close (not shown) between HWRF/S4 and HWRF/Op. Therefore, HWRF/S4 can be used for DA research.



**2017083012 - 2017090912**

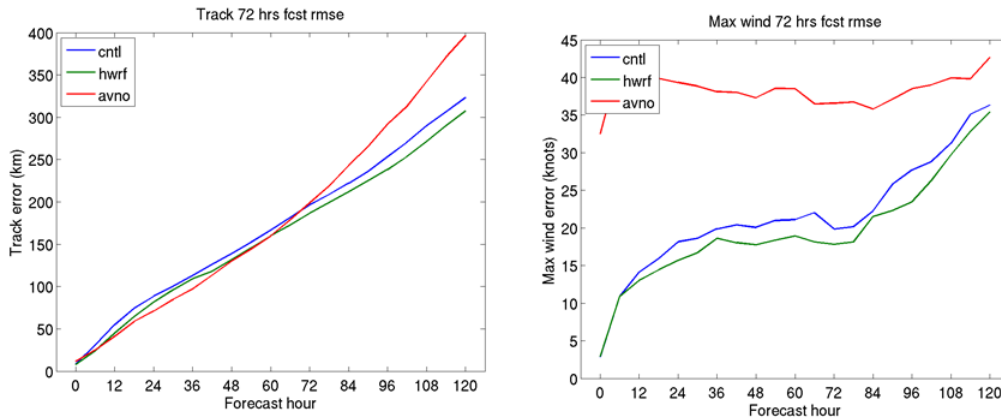

Figure 39. Forecasts from HWRP/Op (upper left), HWRP/S4 (upper right) for hurricane Irma (2017), along with track and intensity forecast statistics against best track estimate (cntl is the results from HWRP/S4, avno is the results from GFS).

**Combined SNPP and GOES-16 data assimilated tested with recent hurricanes**

The three layered precipitable water (LPWs) from GOES-16 ABI have been processed and generated with quality control (QC) for recent hurricanes (Harvey, Irma and Maria). LPWs are from clear skies and they have been converted to BUFR format for GSI to assimilate. In addition, the SNPP CrIS cloud-cleared radiances (CCRs) are also included in the assimilation experiments. Initial experiments on assimilating CrIS CCRs and GOES-16 ABI LPWs are started with CIMSS SDAT, positive impact found on track and intensity forecasts. SDAT (WRF-ARW v3.6.1 forecast system with 12 km resolution together with GSI assimilation system) is used assimilation experiments and impact studies. The control run contains the assimilation of conventional data from GTS (Global Telecommunication System) and satellite data from AMSU-A, IASI, ATMS and CrIS (original radiances). The other three experiments include:  
Control+CCRs, adding CrIS cloud-cleared radiances (CCRs) to control;  
Control+LPWs, adding three LPWs to control;  
Control+CCRs+LPWs, adding combined new information from SNPP and GOES-16 ABI.

Data are assimilated every 6 hours followed by 72 hour forecasts. The experiments are designed to address whether the new satellite information provides value-added impact on TC forecasts. The hurricane track (HT) and maximum wind speed (SPD) Root Mean Square Error (RMSE) have been computed against the best track estimates from National Hurricane Center (NHC).

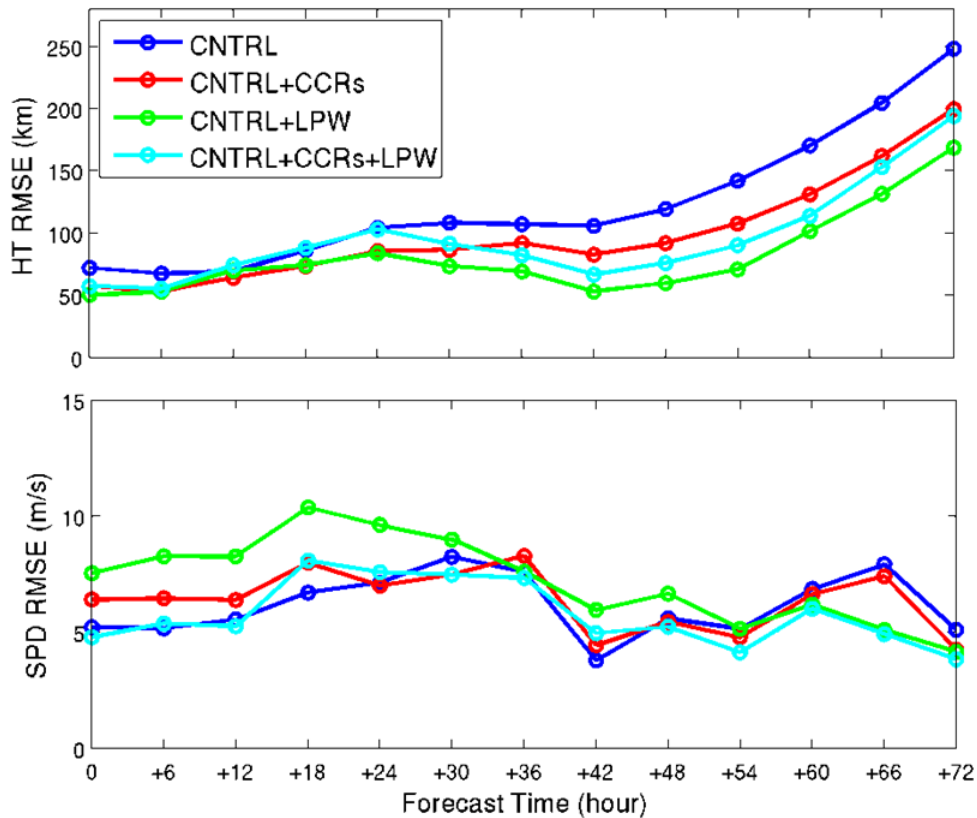

Figure 40. The track (upper) and SPD (lower) forecast RMSE from control run (blue) and the other three experiments, for Hurricane Harvey (2017) forecasts.

Figure 40 shows the track (upper) and SPL (lower) forecast RMSE from control run (blue) and the other three experiments, for Hurricane Harvey (2017) forecasts. Both CrIS CCRs (SNPP) and GOES-16 LPW have improved the control run using the existing conventional and satellite measurements, indicating that CrIS CCRs and LPW added useful information for Harvey forecasts. Combination of CrIS CCRs and LPW improves the control run but does not show better than either CCRs or LPW alone. Better assimilation of combined CCRs from SNPP/JPSS and LPW from GOES-16 will be further investigated, especially with HWRF model.

### Publications and Conference Reports

Wang Pei, Jun Li, Z. Li, A. H. N. Lim, Jinlong Li, T. J. Schmit, and M. D. Goldberg, 2017: The Impact of Cross-track Infrared Sounder (CrIS) Cloud-Cleared Radiances on Hurricane Joaquin (2015) and Matthew (2016) Forecasts, *Journal of Geophysical Research - Atmospheres*, 122, DOI: 10.1002/2017JD027515.

Wang, Pei, Jun Li, Timothy J. Schmit, Jiazhen Lu, Bing Lu, Yong-Keun Lee, Agnes H. N. Lim, Jinlong Li, Zhiquan Liu, Chian-Yi Liu, and Wei Han, 2018: Impact of Moisture information from Advanced Himawari Imager Measurements on Heavy Precipitation Forecasts over land in a regional NWP model, *Journal of Geophysical Research – Atmospheres* (conditionally accepted).

Li et al., 2018: All-sky layered precipitable water products from ABI/AHI and their applications in nowcasting and forecasting the severe storms, 98th American Meteorological Society Annual Meeting, 07 – 12 January 2018, Austin, TX.





Li, J., et al., 2018: Value-added impact from geostationary hyperspectral infrared sounding on nowcasting and forecasting high-impact weather events, 98th American Meteorological Society Annual Meeting, 07 – 12 January 2018, Austin, TX.

## References

Boukabara, S. and Co-authors, 2016: S4: An O2R/R2O Infrastructure for Optimizing Satellite Data Utilization in NOAA Numerical Modeling Systems: A Step Toward Bridging the Gap between Research and Operations, Bulletin of American Meteorological Society, 97, 2359 – 2378.

Li, J., C. Y. Liu, H.-L. Huang, T. J. Schmit, W. P. Menzel, and J. Gurka, 2005: Optimal cloud-clearing for AIRS radiances using MODIS. IEEE Trans. On Geoscience and Remote Sensing, 43, 1266 - 1278.

Li, Jun, P. Wang, H. Han, J. Li, and J. Zheng, 2016: On the assimilation of satellite sounder data in cloudy skies in the numerical weather prediction models, Journal of Meteorological Research. 30, 169-182.

Li, Jun, et al. 2017: Impact of assimilating the VIIRS-based CrIS cloud-cleared radiances on hurricane forecasts. ITSC21, 28 Nov. – 05 Dec 2017, Darmstadt, Germany.

Liu, H., and A. Collard, 2017: Comparison among three cloud-clearing radiance products, ITSC21, 28 Nov. – 05 Dec 2017, Darmstadt, Germany.

Wang, P., Jun Li, M. Goldberg, T. J. Schmit, et al., 2015: Assimilation of thermodynamic information from advanced IR sounders under partially cloudy skies for regional NWP, Journal of Geophysical Research - Atmosphere, 120, doi:10.1002/2014JD022976.

Wang Pei, Jun Li, Z. Li, A. H. N. Lim, Jinlong Li, T. J. Schmit, and M. D. Goldberg, 2017: The Impact of Cross-track Infrared Sounder (CrIS) Cloud-Cleared Radiances on Hurricane Joaquin (2015) and Matthew (2016) Forecasts, Journal of Geophysical Research - Atmospheres, 122, DOI: 10.1002/2017JD027515.

## 10. CIMSS Support to GOES-R SHYMET, Mcidas-V, and Program Support Tasks

### 10.1 CIMSS Participation in SHyMet for 2017

**CIMSS Task Leader: Steve Ackerman**

**CIMSS Support Scientists: Scott Lindstrom, Scott Bachmeier**

**NOAA Collaborators: Tim Schmit, Bill Ward, Brian Motta, Steve Goodman**

**Budget: \$150,000**

#### NOAA Long Term Goals:

- Weather-Ready Nation

#### NOAA Strategic Goals:

- Serve society's needs for weather and water
- Provide critical support for the NOAA mission



### **CIMSS Research Themes:**

- Satellite Meteorology Research and Applications
- Education and Outreach

### **Objective**

SHyMet work at CIMSS focuses on developing current and pertinent case studies that demonstrate Satellite Capabilities in the forecast process.

### **Project Overview**

The role of CIMSS in SHyMet has been to: 1) provide advice on the educational design of the program, 2) assist in the development of the curriculum, 3) support distance education activities, 4) develop and test appropriate satellite education materials, and 5) assist in the teaching of the courses as appropriate. SHyMet seeks to educate NWS forecasters on remote sensing in general and satellite capabilities in particular. Now that GOES-16 is launched, particular emphasis is on replacing dated content (GOES-15 and earlier) with GOES-16-based content.

### **Milestones with Summary of Accomplishments and Findings**

Potential cases for updated SHyMet modules are placed on the CIMSS Satellite Blog (<http://cimss.ssec.wisc.edu/goes/blog>); GOES-16 data are now flowing into both McIDAS and AWIPS at CIMSS; there are many pertinent entries (<http://cimss.ssec.wisc.edu/goes/blog/archives/category/goes-16>). More than 200 examples have been created. Himawari-8 data is an also excellent proxy for GOES-16 (<http://cimss.ssec.wisc.edu/goes/blog/archives/category/himawari-8>).

SHyMet funding underwrote the development of training modules for the Hazardous Weather Testbed at SPC in Norman. An example for NUCAPS soundings is at [this link](http://www.ssec.wisc.edu/~scottl/NUCAPS2017/presentation_html5.html) ([http://www.ssec.wisc.edu/~scottl/NUCAPS2017/presentation\\_html5.html](http://www.ssec.wisc.edu/~scottl/NUCAPS2017/presentation_html5.html)). Training was also recorded for NOAA/CIMSS ProbSevere and for Legacy Atmospheric Profiles.

SHyMet support requested travel to present preliminary GOES-16 ABI results at IGARSS in Fort Worth in July 2017.

SHyMet supported the development of two training modules given remotely to Environment Canada as part of their ‘Train the Trainer’ activities: **Red Green Blue (RGB) Composites with GOES-16 Data** (Presented to Environment Canada Train the Trainer Workshop, Montreal, via WebEx, 25 October 2017) and **GOES-R ABI Spectral Bands and Practical Applications** (Presented to Environment Canada Train the Trainer Workshop, Montreal, via WebEx, 11 September 2017).

### **Publications and Conference Reports**

Lindstrom, S. S., A. S. Bachmeier and T. J. Schmit, 2018: **Communicating new Satellite Technologies through the use of Blog**. 27<sup>th</sup> Symposium on Education, 98<sup>th</sup> Annual Meeting of the American Meteorological Society, 7-11 January 2018, Austin, TX.

Lindstrom, S. S., J. J. Gerth, D. Hoese and R. Garcia, 2018: **Using the Satellite Information Familiarization Tool (SIFT) to Train on New Multi-Spectral Geostationary Satellite Sensors**. 34<sup>th</sup> Conference on Environmental Information Processing Technology and 98<sup>th</sup> Annual Meeting of the American Meteorological Society, 7-11 January 2018, Austin TX.



Lindstrom, S. S., A. S. Bachmeier, J. J. Gerth, T. J. Schmit, M. M. Gunshor, D. Bikos, E. J. Szoke and B. H. Connell, 2018: **VISIT and SHyMet Training Activities at CIMSS**. 14<sup>th</sup> Annual Symposium [on New Generation Operational Environmental Satellite Systems](#) and 98<sup>th</sup> Annual Meeting of the American Meteorological Society, 7-11 January 2018, Austin, TX.

Li, J., J. Gerth, Y.-K. Lee, Z. Li, T. J. Schmit, P. Wang and S. Lindstrom, 2018: **All-Sky Layered Precipitable Water Products from ABI/AHI and Their Applications in Nowcasting and Forecasting the Severe Storms**, 14<sup>th</sup> Annual Symposium on New Generation of Operational Environmental Satellite Systems and 98<sup>th</sup> Annual Meeting of the American Meteorological Society, 7-11 August 2018, Austin TX.

Wimmers, A., S. M. Griffin, A. S. Bachmeier, J. J. Gerth and S. S. Lindstrom, 2018: **Resolving Gravity Waves with Himawari-8 and GOES-16 Imagery at the New Limit of Resolution and the Application to Aircraft-Scale Turbulence**, [Sixth Aviation, Range, and Aerospace Meteorology Special Symposium](#) and 98<sup>th</sup> Annual Meeting of the American Meteorological Society, 7-11 August 2018, Austin TX.

Jasmin, T., S. S. Lindstrom, A. S. Bachmeier and T. T. Whittaker 2018: **VISITview: 20 Years of Forecaster Training and Counting**. 34<sup>th</sup> Conference on Environmental Information Processing Technology (EIPT) and 98<sup>th</sup> Annual Meeting of the American Meteorological Society, 7-11 August 2018, Austin TX.

Ward, B., [F. Alsheimer](#), [B.C. Carcione](#), [C. B. Entwistle](#), R. D. Ewald, M. T. Stavish, G. T. Stano, K. W. Mozer, J. J. Gerth, S. S. Lindstrom, T. J. Schmit, C. M. Gravelle, K. J. Runk, M. A. Bowlan, J. G. LaDue, J. E. Ogren, E. J. Szoke, D. Bikos, 2018: **Workshops on GOES-16 Data for National Weather Service SOOs and DOHs**. [14th Annual Symposium on New Generation Operational Environmental Satellite Systems](#) and 98<sup>th</sup> Annual Meeting of the American Meteorological Society, 7-11 January 2018, Austin TX.

Lindstrom, S., T. J. Schmit, M. Gunshor, J. Daniels, K. Bah and S. J. Goodman, 2017: **Latest Assessment of GOES-R (16) Advanced Baseline Imager (ABI) Data Quality from an Application and Training Perspective**, IGARSS 2017, Fort Worth, TX, M03.L8.

## **10.2 Senior Scientist Support of the GOES-R Program Office**

**CIMSS Task Leader: W. Paul Menzel**

**NOAA Collaborators: Tim Schmit, Steve Goodman**

**Budget: \$50,000**

### **NOAA Long Term Goals:**

- Climate Adaptation and Mitigation
- Weather-Ready Nation

### **NOAA Strategic Goals:**

- Serve society's needs for weather and water
- Understand climate variability and change to enhance society's ability to plan and respond
- Provide critical support for the NOAA mission



### **CIMSS Research Themes:**

- Satellite Meteorology Research and Applications
- Satellite Sensors and Techniques
- Education and Outreach

### **Objective**

Dr. W. Paul Menzel (WPM) to participate in research on environmental remote sensing systems that helps to guide NOAA in evolving the GOES-R and JPSS satellite holdings

### **Project Overview**

Project includes (1) facilitating research demonstrations of new capabilities from GOES-R and JPSS, (2) teaching remote sensing seminars to new researchers, (3) participating in Technical Advisory Committees, JPSS Reviews, and other evaluations, (4) presenting research results at appropriate venues, and (5) collaborating with international partners pursuing the same goals.

### **Milestones and Summary of Accomplishments and Findings**

#### ***David Johnson Award***

Dr Menzel served again on the David Johnson Award selection panel in October 2017. Scott Rudlosky was chosen for the award this year for his work in preparing NOAA for using GOES Lightning Mapper data upon launch.

#### ***Sounding Publication***

Dr Menzel is the lead author on a March 2018 BAMS paper. The reference is Menzel, W.P., T. J. Schmit, P. Zhang, and J. Li, 2018: Satellite based atmospheric infrared sounder development and applications. Bull. Amer. Meteor. Soc., doi: 10.1175/BAMS-D-16-0293.1.

#### ***AOMSUC-8***

The eighth Asia/Oceania Meteorological Satellite Users' Conference (AOMSUC-8) was held in Vladivostok, Russia from 18-20 October 2017. The conference was hosted and sponsored by the Roshydromet of the Russian Federation, and was co-sponsored by the China Meteorological Administration (CMA), the Japan Meteorological Agency (JMA), the Korea Meteorological Administration (KMA), the Australian Bureau of Meteorology (AuBOM), and the World Meteorological Organization (WMO). A training event was conducted prior to the conference that brought together participants from WMO Regions II and V. Over 150 scientists, users, and satellite operators representing over 25 countries participated. Noting that the successful launch and operation of the Japanese Himawari-9 and the Chinese FY-4A in the past year offered unprecedented new capabilities to Asia-Oceania as well as to the Space Based Component of the WMO Integrated Global Observing System (WIGOS), the participants welcomed the efforts being undertaken to introduce and utilize these new data. AOMSUC-8 was focused on coordination in the generation of new products and services and the preparation for their utilization by the worldwide user community. Dr. Menzel served on the organizing committee for the conference and gave a talk on cloud and moisture trends. The AOMSUC-8 agenda and other information are available at <http://aomsuc8.ntsomz.ru/shedule/>.

#### ***GIIRS Data Study***

Clear sky BT spectra (1650 channels) for the Geostationary Interferometric Infrared Sounder (GIIRS) on FY4A were calculated upon receiving the specifications from Dr. Qiang Guo (NSMC/CMA). These are LWIR (700 - 1130 cm<sup>-1</sup>): 689 channels at 0.625 cm<sup>-1</sup> resolution and SWIR (1650 - 2250 cm<sup>-1</sup>): 689 channels at 0.625 cm<sup>-1</sup> resolution. The figure below shows

example spectra for various standard atmospheres. The Sounder Radiative Transfer Model is described in [ftp://ftp.ssec.wisc.edu/pub/ssec/eweisz/FengYun\\_RTM\\_ATBD\\_2011.pdf](ftp://ftp.ssec.wisc.edu/pub/ssec/eweisz/FengYun_RTM_ATBD_2011.pdf).

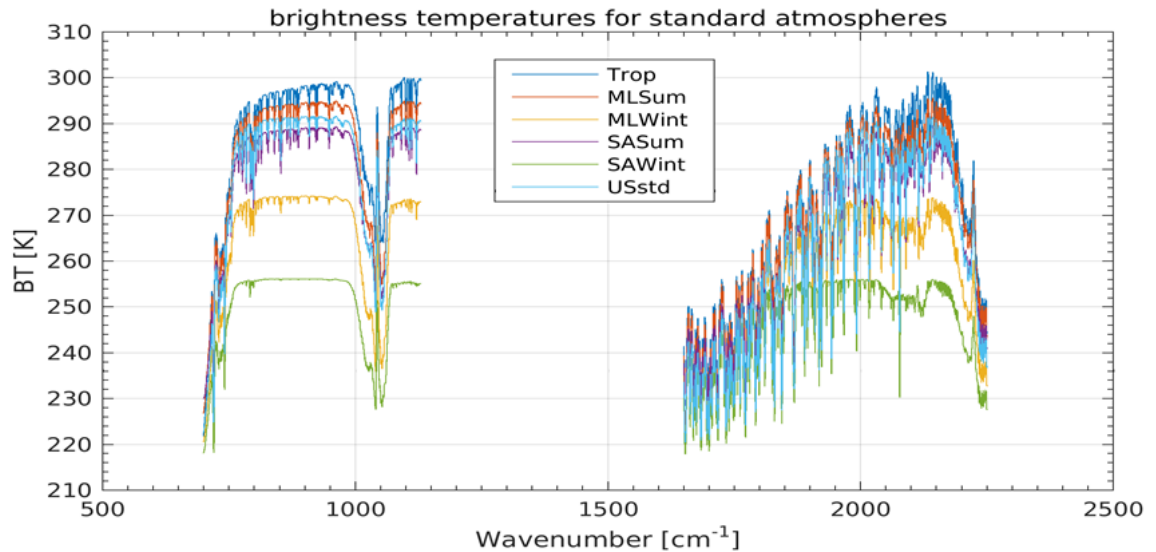

Figure 41. GIIRS Spectra for various standard atmospheres.

### Remote Sensing Seminars

Dr Menzel conducted two remote sensing seminars in the past year – for six weeks in late March through early May 2017 and again for one week in January 2018. Students got practical experience working with visualization software called HYDRA, utilizing data from the Community Satellite Processing Package (CSPP), learning how to create composite multi-spectral images, and identifying environmental signatures. The first course emphasized the capabilities of Suomi NPP to depict land, ocean, and atmospheric features; the second course focused on the new capabilities offered by the GOES imager – ABI.



Figure 42. Jan 2018 Remote Sensing Seminar attendees.



## Suomi Book

“Verner Suomi – The Life and Work of the Founder of Satellite Meteorology” was published by the American Meteorological Society. Dr Menzel is one of the co-authors.

### Verner Suomi

The Life and Work of the Founder of Satellite Meteorology  
JOHN LEWIS et al.

As the space age got underway in the wake of Sputnik, one of the earliest areas of science to take advantage of the new observational opportunities it afforded was the study of climate and weather. This book tells the story of Finnish-American educator, inventor, and scientist Verner Suomi, who, in those early days of space science, brought his pragmatic engineering skills to bear on finding ways to use our new access to space to put observational instruments into orbit. In 1959, Suomi's work resulted in the launching of Explorer VII, a satellite that measured the earth's radiation budget, a major step in our ability to understand and forecast weather. Drawing on personal letters and oral histories, the book presents a rounded picture of the man who launched the field of satellite meteorology—in the process changing forever the way we understand and interact with the weather around us.

**John M. Lewis** is a research meteorologist at National Severe Storms Laboratory and visiting professor of atmospheric science at Desert Research Institute and the University of Nevada-Reno.

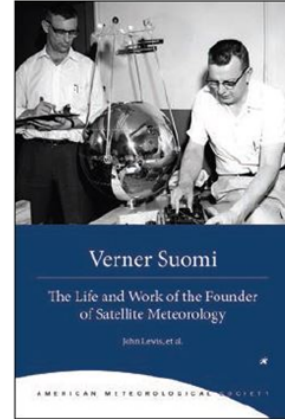

FEBRUARY 168 p., 30 halftones,  
30 line drawings 6 x 9  
ISBN-13: 978-1-944970-22-2  
Paper \$35.00s/£26.50  
E-book ISBN-13: 978-1-944970-23-9  
BIOGRAPHY SCIENCE

Figure 43. University of Chicago Press description of Suomi Book.

## 10.3 McIDAS-V Support for GOES-R

**CIMSS Task Leader: Thomas Rink**

**NOAA Collaborator: Brad Pierce**

**Budget: \$29,000**

### NOAA Long Term Goals:

- Climate Adaptation and Mitigation
- Weather-Ready Nation

### NOAA Strategic Goals:

- Serve society's needs for weather and water
- Understand climate variability and change to enhance society's ability to plan and respond
- Provide critical support for the NOAA mission

### CIMSS Research Themes:

- Satellite Meteorology Research and Applications
- Satellite Sensors and Techniques
- Environmental Models and Data Assimilation
- Education and Outreach

### Objective

To make improvements to 3D Visualization of wind parcel trajectories.



## Project Overview

Design and develop forward/reverse wind parcel trajectory computation and visualization through 2D/3D, earth navigated, gridded Eulerian wind fields with interactive control in McIDAS-V. Potential applications relevant to GOES-R, and under development, include: display 3D trajectories through time based on ABI retrieved Aerosol optical depth (AOD) and numerical model wind forecast, visualize the forward trajectories of parcels in the vicinity of volcanic eruption with respect to ash/SO<sub>2</sub> retrievals, trace conservative atmospheric stability parameters such as Equivalent Potential Temperature from NWP or analysis wind field.

## Milestones with Summary of Accomplishments and Findings

Improved trajectory cylinder form rendering to generate visually smoother shaded surface. This depiction of parcel path is particularly useful improving depth perception in 3D displays. Backward parcel propagation has been implemented (a few bugs yet, but in testing). This provides the capability, for example, to determine the air mass source by tracing backward from a parcel's current position and time. Implement terrain following flow adjustment for boundary layer parcels interacting with complex terrain. Terrain information can be retrieved from the model dataset, or specified externally via an earth navigated serialized data structure and automatically resampled to the model domain to account for resolution difference if needed.

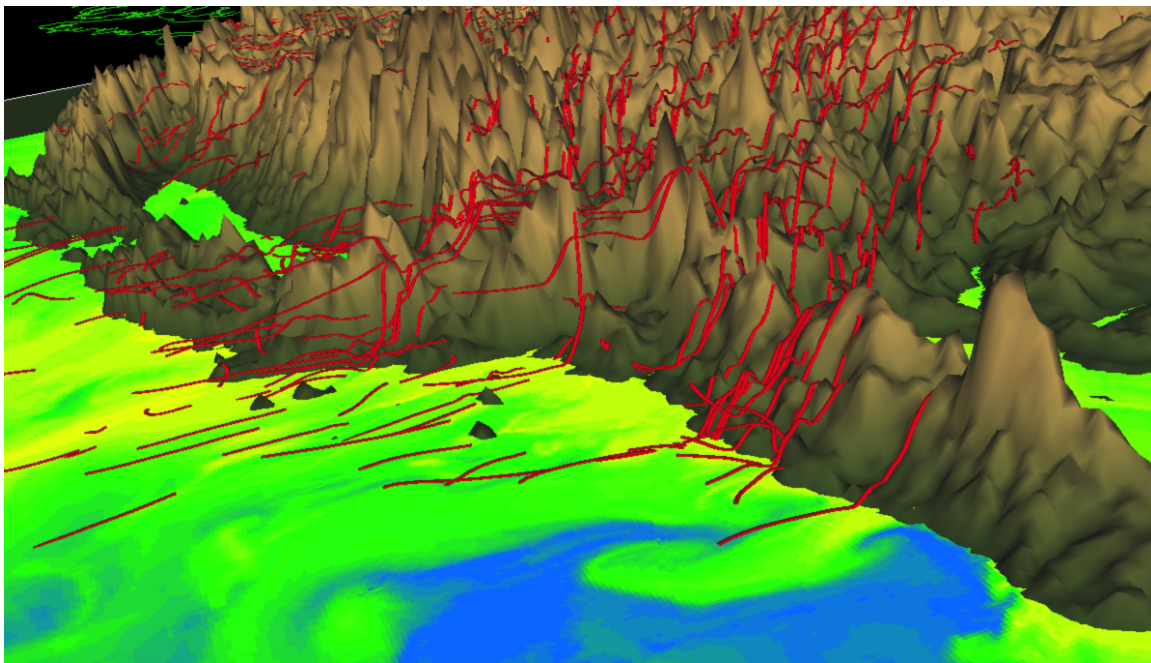

Figure 44. California wild fire event near the time of some of the most extreme Santa Ana wind gusts, Dec 5 to 6. Parcel trajectories, rendered as red cylinders, initialized in the boundary layer for a set of points over the Great Basin, and propagated forward with a 24hr, NAM 4km forecast starting at 18Z. The color shaded field (low, yellow to high, blue) is 1000mb Relative Humidity.

## Publications and Conference Reports

AMS Annual Meeting (IIPS): 2005-2016, 2018  
AMS Satellite Meteorology Conference: 2007, 2009, 2010, 2012, 2016  
AGU Fall Meeting: 2005, 2007-2011  
SPIE Photonics: 2007-2011  
NOAA Direct Broadcast: 2008, 2011  
GOES-R User's Conference: 2009 (workshop), 2010, 2011  
EUMETSAT Satellite Conference: 2008 (workshop), 2009-2012



International TOVS Working Group Meeting: 2007, 2008, 2010 (workshop), 2012  
McIDAS Users Group: 2006-2017 (workshops 2008-2017)

## **11. Development of a Geostationary Community Satellite Processing Package (CSPP) / Supplemental Tasks**

**CIMSS Task Leaders: Liam Gumley (PI), Graeme Martin (PM)**

**CIMSS Support Scientists: Nick Bearson, Jessica Braun, Geoff Cureton, Alan De Smet, Ray Garcia, Tommy Jasmin, Scott Mindock, Eva Schiffer, Kathy Strabala**

**NOAA Collaborators: Steve Goodman, Satya Kalluri, Andrew Heidinger, Michael Pavolonis, Walter Wolf**

**Budget: \$592,000**

### **NOAA Long Term Goals:**

- Weather-Ready Nation

### **NOAA Strategic Goals:**

- Serve society's needs for weather and water
- Provide critical support for the NOAA mission

### **CIMSS Research Themes:**

- Satellite Meteorology Research and Applications
- Satellite Sensors and Techniques

### **Objective**

The primary goal is to support processing of GOES Rebroadcast (GRB) data received from GOES-16. Additional goals are to support processing of direct broadcast data from the GOES-13, GOES-15 and Japanese Himawari-8 satellites.

### **Project Overview**

The CSPP Geo project supports the US and international community of direct broadcast users by developing and distributing software allowing them to process data received from geostationary satellites, generating data products locally in real-time.

CSPP Geo software is free to download and install, and is designed to be run at a direct broadcast receiving station on relatively modest hardware. The software is easy to install and run, and all required third-party software is bundled with the software package. Test datasets are provided, to allow users to verify correct installation and operation. Users can optionally plot products using “quicklook” image software. A high level of technical support is provided.

CSPP Geo software is widely used by vendors of direct broadcast receiving and processing systems, U.S government agencies, including the National Weather Service (NWS) and NASA, providers of data products and services, foreign meteorological agencies and forecast offices, and the academic and research community, including NOAA cooperative institutes. To date, users from more than 30 countries have registered to download CSPP Geo software. Based on information from the GRB User Group, the majority of direct broadcast users who operate GRB receiving stations are running CSPP Geo software.





## Milestones with Summary of Accomplishments and Findings

Major milestones achieved during the reporting period included multiple releases of the GRB and AIT Framework Level 2 software packages for GOES-16. These releases allowed direct broadcast users to start generating products from all GOES-16 instruments soon after they were added to the GRB stream, and to further process ABI data to generate Level 2 products. Other accomplishments included assisting users with setting up GRB reception and processing, contributing to GRB Post Launch Testing (PLT), and improvements to Level 2 product software for Himawari-8 AHI and AXI-Tools software for data conversion and tiling.

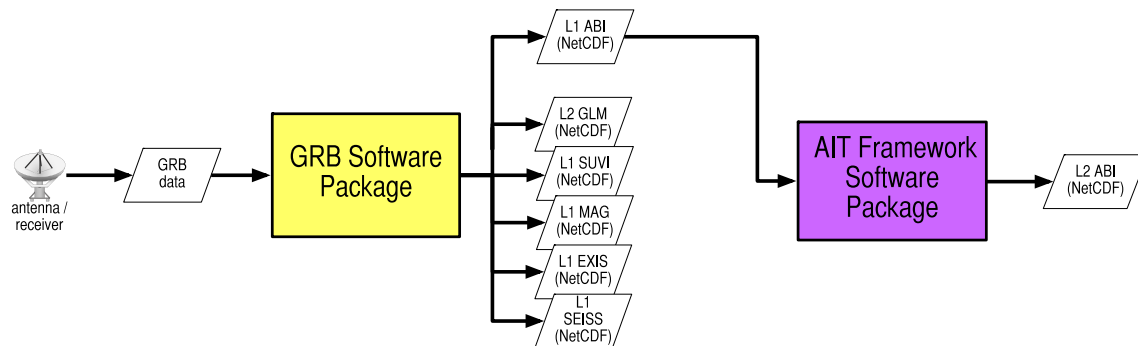

Figure 45. CSPP Geo processing chain for GOES-16 GRB.

### GRB Package

The function of this software is to process the raw GOES-16 GRB stream as it comes from a demodulator, generating Level 1 ABI and space weather products, and Level 2 GLM products. The GRB Software Package was developed following the technical specifications described in the GOES-R Product Users' Guide. Early prototype versions of the software were distributed in the GOES-R pre-launch period to encourage GOES-R preparedness. During the reporting period, as instruments were added to the GRB stream we continued to release “dev snapshot” versions of the software incorporating the latest improvements, allowing users to generate products as soon as possible. The current version of the GRB package generates products from all GOES-16 instruments, and is widely used at GRB receiving stations in the US and internationally.

We provided technical assistance to users as they built and tested their systems, helping to install and configure software and troubleshoot problems affecting their GRB receiving and processing systems. In some cases, we compared users' products and system performance with the GRB system operated by CIMSS / SSEC.

We participated in PLT via the GRB User Group, helping to evaluate the GRB stream and identify issues by providing product counts and quality assessments back to the ground system, and by comparing our results to reports from other receiving sites. We reported issues affecting the GRB stream to the PRO team (metadata ordering, packet delays), provided analyses of known issues and their impact on users, and suggested solutions. We participated in the GRB User Group splinter discussions regarding known issues, and provided feedback on proposed changes to the GRB stream.

Activities related to software development included: analyzing program performance during events affecting data quality (dropouts, outages, data duplication, channel crossing) and improving handling of error conditions; developing quicklook image generation capabilities; improvements to logging, including demodulator health monitoring and reporting of issues with



the GRB stream or reception; adding support for UDP multi-cast as requested by the NWS; optional compression of NetCDF output; workarounds for known issues affecting the GRB stream; stress testing, profiling and optimization; acquisition and configuration of a test machine matching the minimum GRB hardware specification; comparison of output with products from PDA; demonstration of streaming capabilities using the real-time tracking interface, and various other bug fixes and improvements.

We are currently working toward the Version 1.0 release of the GRB package, which will include improved performance and robustness, configuration changes, and various other enhancements and features requested by users.

### ***AIT Framework Level 2 Software Package for ABI***

This software allows users to process ABI L1B data from the GOES-16 GRB stream, generating a subset of the baseline Level 2 products. During the reporting period, alpha and beta versions of the AITF package were released. The software was well-received by users, and feedback from testers was used to improve the software.

This software package was developed as part of an ongoing collaboration with the GOES-R Algorithm Integration Team (AIT) at NOAA, who are the maintainers of the core science software. The CSPP Geo package consists of research implementations of the operational product algorithms running in the AIT Framework, and a CSPP Geo-developed scripting infrastructure that allows it to run on a relatively inexpensive shared-memory multi-core server in a direct broadcast setting. The primary tasks of the logic developed by the CSPP Geo team are job sequencing, ancillary data downloads, data format conversion, CMI product creation, segmentation and stitching to allow parallel processing, logging, error recovery and quicklook image generation.

Activities related to software development included: improvements to multi-processing including spatial overlap; developing CMI creation capability; testing of forward processing of real-time GRB data; profiling and performance optimizations to run on the recommended hardware; interface development and testing; assessment of products and comparison with baseline products from the AIT and the ground system; identification of algorithm issues and resolution or reporting to the AIT; and implementation of robust, atomic ancillary data downloading and syncing logic.

Periodic code drops with updates to the framework and science algorithms were accepted from the AIT, tested and integrated into the CSPP Geo software infrastructure. Technical issues were discussed in biweekly telecons with the NOAA AIT group; topics included software development, algorithm deliveries and integration, product issues and schedule expectations.

Improvements were made to quicklook image scripting, including significant performance improvements, transitioning to a new codebase, enhanced configurability, and gathering and incorporating feedback from scientists and other domain experts.

Currently we are working toward the Version 1 AIT Framework release, expected in Spring 2018.

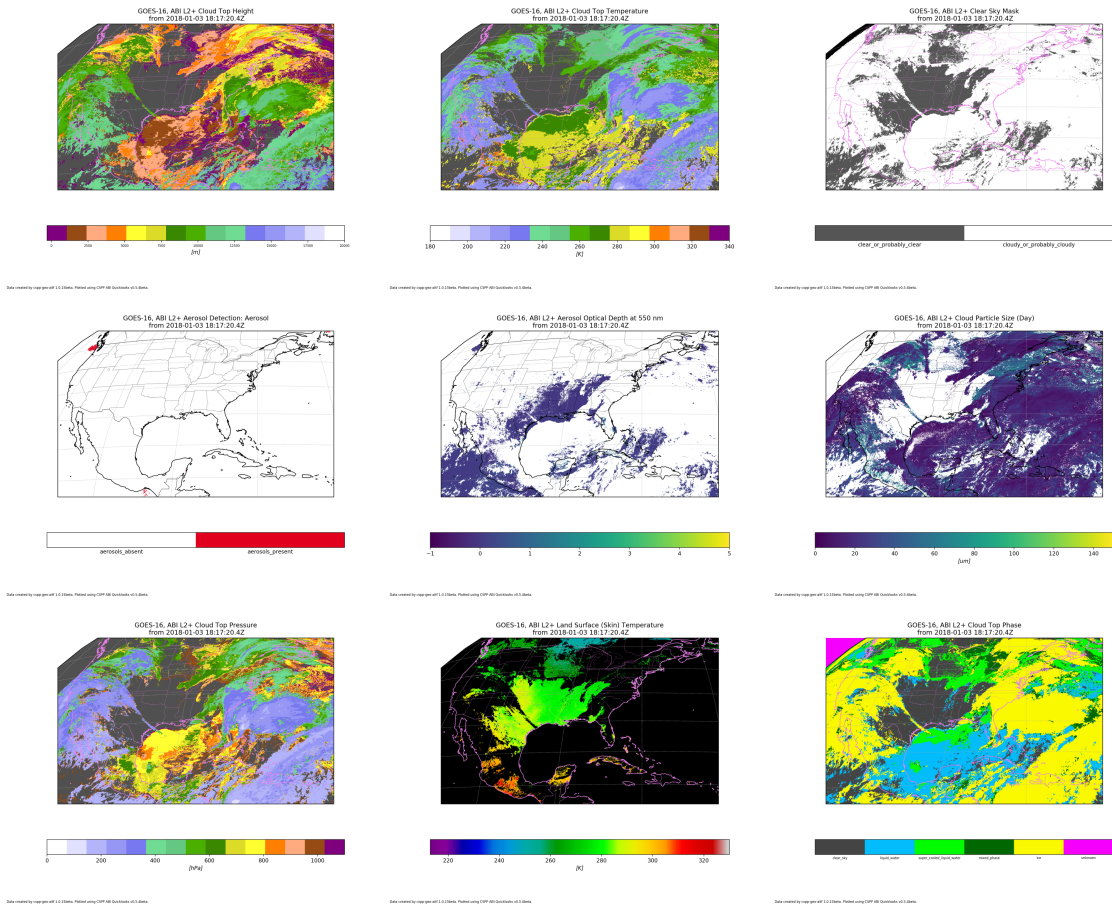

**Figure 46. Quicklook images showing examples of Level 2 products generated by the AIT Framework package running on ABI data received via GRB.**

### ***GEOCAT Level 2 Software Package for AHI***

Progress was made on the GEOCAT Level 2 package for Himawari-8 AHI. The software package was developed in collaboration with the groups that maintain the core GEOCAT software and science algorithms, led by Michael Pavolonis and Andrew Heidinger. The current beta version allows users to run research versions of the GOES-R Level 2 algorithms which have been adapted to process data from the Advanced Himawari Imager.

Activities and software improvements included: bug fixes; quicklooks enhancements; improvements to multi-processing including spatial overlap; added support for temporal dependencies; added data subsetting capability; testing; contributions to the shared AHI ingest library; tracking and evaluation of changes to HSD and HimawariCast affecting data format and data quality.

We are currently working toward the Version 1 release of the GEOCAT package, expected in Spring 2018.

### ***User Support and Outreach***

The CSPP Geo website and user forum were maintained as the distribution point for software packages, patches, system requirements information and technical documentation. Software release announcements and other project news and plans were communicated to users via the



website, the user forum and by email. We responded to a large number of support requests received via our user support email list. We presented briefings and interacted with users at the NOAA Satellite Meeting, and at the AOMSUC, ITSC and AMS conferences. The third CSPP / IMAPP Users' Conference was held in June 2017 in Madison, Wisconsin, and offered users from throughout the US and the world an opportunity to share the results of their work, to learn from and collaborate with their peers, and to interact directly with the CSPP Geo team.

Other common and cross-cutting tasks included development of build and packaging automation; contributions to the ShellB3 portable Python runtime library; platform portability testing and issue resolution; maintenance of common facilities such as development and test servers, version control, issue tracking software, Slack communication software and the user mailing list; continued distribution of software to process legacy GVAR / GOES-13 and -15 data; formulation of common guidelines for software installation and configuration, versioning, naming conventions, user interfaces, and the appearance of quicklook images.

User documentation was developed and updated for each software release, describing installation and configuration of software, install verification, usage information, and products and data formats.

We contributed to development of AXI-Tools, a script library for data tiling and format conversion. AXI-tools is currently being used at NWS direct broadcast receiving sites to convert products to Sectorized CMI (SCMI) format, for compatibility with AWIPS 2. In addition, we helped NWS to install and configure CSPP Geo software, and to prepare for an upcoming evaluation of CSPP Geo software.

Dynamic ancillary data required for level 2 product generation such as NWP, OISST and snow mask were acquired, converted, and staged for users on a public-facing server located at CIMSS.

## **12. GOES-R Specific Mobile Apps**

**CIMSS Task Leader: Sam Batzli**

**CIMSS Support Scientists: Dave Parker, Russ Dengel, Nick Bearson, Tommy Jasmin, Dave Santek**

**NOAA Collaborator: Jeff Key, Tim Schmit, Steve Goodman**

**Budget: \$28,000**

### **NOAA Long Term Goals:**

- Climate Adaptation and Mitigation
- Weather-Ready Nation

### **NOAA Strategic Goals:**

- Serve society's needs for weather and water
- Understand climate variability and change to enhance society's ability to plan and respond
- Provide critical support for the NOAA mission

### **CIMSS Research Themes:**

- Satellite Meteorology Research and Applications
- Education and Outreach



## Objective

To develop and improve apps highlighting GOES imagery and products.

## Project Overview

The launch of GOES-R has brought unprecedented quality and volume of geostationary satellite imagery to scientists and weather forecasters. All of these new products will be viewable in the RealEarth web browser and related mobile app. However, because of the profusion of GOES imagery and derived products, we are developing a dedicated, GOES-branded complimentary app specifically for GOES imagery and products, called “GOES App.”

## Milestones with Summary of Accomplishments and Findings

### *Upgrading WxSat*

Completed the upgrade of WxSat in the form of “RealEarth” App. The RealEarth App was released to both the Android and iOS stores in the fall of 2016. Both have been met with enthusiasm with thousands of downloads of the Android app and iOS app since release. All GOES products available in the RealEarth browser are available in these apps.

### *Infrastructure Supplement and GOES Product Development*

The RealEarth team added a dedicated GOES server and VM to the network in support of this project. This allowed us to be among the very first to showcase GOES-16 non-operational imagery in near real-time for general public and science users. The response was overwhelmingly positive. In fact, at any given time, the new GOES-16 products are the most popular products of the over 600 available in RealEarth. RealEarth currently hosts 84 GOES-16 full-disk, CONUS, and Meso products with more on the way. View them at <https://goes.ssec.wisc.edu>

### *Dedicated GOES App Released July 2017*

With the infrastructure in place to handle GOES-16 and we added that imagery into the RealEarth App. We also established the stand-alone iOS and Android dedicated GOES Apps, released at the NOAA Satellite Conference in New York City, July 2017. The GOES App(s) include all the features of the RealEarth App(s) (such as pan and zoom, animation, user location identification, basemap, product search, and overlay of country outlines), but provide a streamlined way to get immediately to the grouped and categorized imagery and products from the GOES legacy and GOES-16 systems. Already over 5,000 copies of the iOS App and over 1,000 of the Android version have been downloaded. The Apps are also GOES-17-ready.

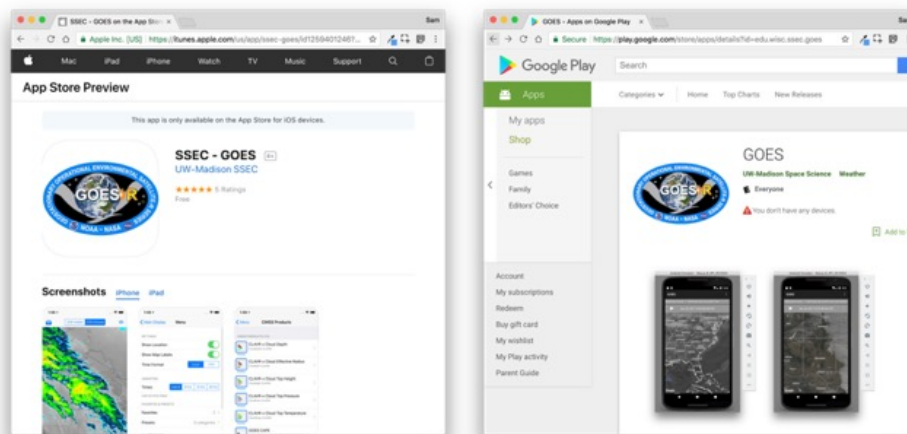

Figure 47. These screenshots show the GOES App in the iOS and Google Play stores.



## **Publications and Conference Reports**

Poster at PECORA 20 Symposium, Sioux Falls, SD, November 2017.

Poster and Demo at the NOAA Satellite Conference, City College of New York, New York, NY. July 2017.

Presentation at AMS, Seattle, WA. January 2017.

Poster at the AGU, San Francisco, CA. December 2016.

## **13. CIMSS Support to Participate in GOES-R Visiting Scientist Program 2017**

### **13.1 Development of Advanced Data Assimilation Techniques for Improved use of Satellite-Derived Atmospheric Motion Vectors in Hurricane Forecasting**

**CIMSS Task Leader: Agnes Lim**

**Budget: \$6,351**

#### **NOAA Long Term Goals:**

- Weather-Ready Nation

#### **NOAA Strategic Goals:**

- Serve society's needs for weather and water

#### **CIMSS Research Themes:**

- Environmental Models and Data Assimilation

#### **Objective**

To exchange quality control and assimilation techniques between NOAA and BoM on optimizing techniques for using high temporal AMV data to improve tropical cyclone (TC) forecasts.

#### **Project Overview**

BoM had developed an operational Himawari-8 local 10-minute Atmospheric Motion Vector (AMV) generation system and after assimilation tests, is now using local 10-minute winds in its operational data assimilation suite (Le Marshall et. al, 2017). AMVs can also be generated at this high temporal resolution from the GOES-16 using the new nested tracking algorithm (Bresky, 2012). Visit to the Bureau of Meteorology (BoM), Australia took place from the 2 to 7 October 2017.

#### **Milestones with Summary of Accomplishments and Findings**

During the visit, techniques used at BoM on assimilation of high temporal winds putting it in the context of tropical cyclones whenever possible were reviewed (Le Marshall et al, 2013a, 2013b, 2016 and 2017). The two key quality control (QC) parameters used are the Expected Error or EE (Le Marshall et. al., 2004) and the Quality indicator, QI (Holmlund, 1998). At BoM, thresholds of QC and EE are determined by comparing statistics of model and analysis errors. These thresholds do not change a lot with time. A review of threshold will however be needed when the forecast model is upgrade. Use of both QI and EE can further help to improve the quality of data assimilated compared to using only either one. The regression coefficients used to calculate EE



were derived a while ago and may need to be updated for the newer satellite. Spatial thinning should not be needed, as QI and EE will have reduced the correlation. A good coverage and good quality data is however necessary. Use of all winds available rather than winds derived from images +/-15 min of the hour for assimilation will be preferred. with the nested tracking algorithm.

For TC forecast, relaxing the QCs to allow larger variation in the AMVs to be assimilated. It is not necessary for the observations to have to correct the analysis at the first time, rather continuous nudging of the analysis from the AMVs every 6 hours. High temporal winds help to fill up regions of observation coverage quickly. potential of using Australia city models to run the TC with 15 min 4dvar will be looked into. Clear air water vapor winds are especially important to define fronts because of the moisture gradient

### References

- Bresky, W., . Daniels, A. Bailey, and S. Wanzong, 2012: New Methods Towards Minimizing the Slow Speed Bias Associated With Atmospheric Motion Vectors (AMVs). *J. Appl. Meteor. Climatol.*, **51**, 2137-2151.
- Holmlund, K., 1998: The utilization of statistical properties of satellite derived atmospheric motion vectors to derive quality indicators, *Wea. Forecasting*, **13**, 1093-1105.
- Le Marshall, J., A. Rea, L. Leslie, R. Seecamp and M. Dunn, 2004: Error Characterization of Atmospheric Motion Vectors, *Aust. Met. Mag.*, **53**, 123-131.
- Le Marshall J., R. Seecamp, Y. Xiao, P. Gregory, J. Jung, P. Stienle, T. Skinner, C. Tingwell, and T. Le, 2013a: The operational generation of continuous winds in the Australian region and their assimilation with 4dvar. *Wea. Forecasting*, **28**, 504–514.
- Le Marshall J., J. Lee, J. Jung, P. Gregory and B. Roux, 2013b: The considerable impact of earth observations from space on numerical weather prediction, *AMJ*, **63**, 497-500.
- Le Marshall, J., Xiao, Y., Howard, D., Tingwell, C., Freeman, J., Gregory, P., Le, T., Margetic, D., Morrow, T., Daniels, J., Jung, J., Bresky, W., Bailey, A. and Wanzong, S. 2016, First results from the generation and assimilation of 10-minute atmospheric motion vectors in the Australian region, *JSHESS*, **66**, 12–18.
- Le Marshall, J., D. Howard, Y. Xiao, J. Daniels, S. Wanzong, J. Jung, W. Bresky, A. Bailey, C. Tingwell, T. Le and D. Margetic, 2017: Himawari-8 Atmospheric Motion Vectors- Operational Generation and Assimilation, *JSHESS*, **67**(1), 12-24.

### 13.2 Exploring Innovative Ways to Use Satellite Observations to Verify the Accuracy of Numerical Weather Prediction Model Forecasts

**CIMSS Task Leader: Jason Otkin**

**Budget: \$6,000**

#### NOAA Long Term Goals:

- Weather-Ready Nation



### **NOAA Strategic Goals:**

- Serve society's needs for weather and water

### **CIMSS Research Themes:**

- Environmental Models and Data Assimilation

### **Objective**

The main objective of this project was to foster an exchange of ideas regarding the use of satellite observations for verification of numerical weather prediction (NWP) model forecasts.

### **Project Overview**

An accurate depiction of the cloud field is necessary for NWP models to produce skillful weather forecasts. Cloud processes, however, are very complex and often difficult to accurately represent in NWP models because of nonlinear interactions between different cloud hydrometeor species and the local thermodynamic environment occurring at spatial and temporal scales that are much smaller than those represented by the NWP models. Large uncertainties in the spatial distributions of clouds and water vapor in the model initialization datasets compound these difficulties by affecting cloud generation and dissipation processes during the forecast. The cloud and water vapor fields, however, are difficult to observe because they can be highly variable in space and time and are poorly sampled by conventional observations. To thoroughly assess the accuracy of cloud and water vapor forecasts, it is necessary to use satellite brightness temperatures sensitive to these fields because they are the only observations that can provide detailed information over long time periods and for large spatial domains. In recent years, the so-called “model-to-satellite” approach in which a forward radiative transfer model is used to convert model forecast data into simulated brightness temperatures that are then used to assess the forecast accuracy has gained acceptance as a useful model verification approach.

During the proposed visiting scientist trip to the Met Office and ECMWF, meetings will be held with model developers and data assimilation experts to discuss the merits of existing verification methods and to discuss development of new satellite-based analysis methods. The conversations will primarily focus on the use infrared brightness temperatures for model verification and data assimilation. The proposed project is highly relevant to the GOES-R satellite program because the exchange of ideas fostered by these discussions will lead to improved use of GOES-16 observations in a variety of NWP models.

### **Milestones with Summary of Accomplishments and Findings**

Many very useful discussions were held with researchers at the Met Office and ECMWF working on a variety of topics related to model verification, model physics development, and data assimilation. Seminars discussing results from our recent model verification and data assimilation projects were also given at both organizations. A broad overview of the discussions held at each organization is provided below.

#### ***Met Office Visit (29 – 30 January 2018)***

During my 2-day visit to the Met Office, discussions were held with about a dozen people working on model verification, data assimilation, radiative transfer modeling, and model physics. Several meetings were held with members of the forecast verification team to discuss current and future model visualization and verification capabilities. There was a lot of interest in the real-time satellite-based verification webpage that we developed during a previous project for the HRRR model (<http://cimss.ssec.wisc.edu/hrrrval/>) as well as in our use of a wide variety of statistical methods to assess the forecast accuracy in regional and global models. For example, many people





liked the forecast error matrices that are displayed on the HRRR verification webpage because they show how the forecast errors have been changing with time in an easy to understand format. It was also noted that being able to zoom in on specific regions of interest is useful both for operational forecasters and for longer-term verification efforts because the model errors may be different in each region due to differences in cloud characteristics or flow regimes. In return, they demonstrated the utility of using slider panels to overlay the observed and forecast satellite imagery. This visualization approach has proven useful for forecasters because it allows them to more easily compare structures in the observed and forecast satellite images over small regions than can be achieved through side-by-side comparisons of larger images. It also means that the image size can be increased because effectively only one image is shown on the screen at a time, thereby allowing more detail to be shown on the images. We will consider using this visualization approach in future versions of our real-time verification webpage.

The Met Office has been providing their operational forecasters simulated geostationary satellite imagery for some time; however, they are planning to start using the simulated satellite brightness temperatures for quantitative verification in the near future. Given the wide array of verification methods that can be employed for this purpose, much time was spent discussing which methods are most useful. Though each verification approach (e.g., traditional grid point, neighborhood, and object-based) has its strengths and weaknesses, it was agreed that it is most beneficial to assess the forecast accuracy using a variety of statistical methods because together they provide a more comprehensive evaluation of the forecast accuracy than any one method can provide by itself. The verification group was keen to hear my recommendations regarding optimal ways to use satellite observations for forecast verification so that they could leverage the extensive expertise that we have gained in recent years. I recommended that they start with traditional statistical metrics (RMSE, bias) because they are easy to interpret and use, but that the most valuable information will be obtained through use of more advanced neighborhood- and object-based verification methods. These include methods such as the Fractions Skill Score and the Method for Object-based Diagnostic Evaluation (MODE) system, both of which we have used in prior studies. I also emphasized the added value that 2-dimensional error graphics such as brightness temperature probability distributions plotted as a function of forecast hour provide when compared to 1-dimensional error profiles or statistics tables. These 2-dimensional error graphics are more helpful because they provide more detailed information that can be used to identify potential sources of forecast errors, which may be obscured in simple summary statistics.

Meetings were also held with developers of RTTOV, where it was mentioned that a new ice cloud property lookup table has been added to the radiative transfer model, with the developer of the cloud microphysics parameterization scheme used in their global and regional modeling systems, and with members of the satellite data assimilation team.

### ***ECMWF Visit (01 – 02 February 2018)***

Similar to the Met Office visit described in the previous section, numerous meetings were held with scientists at ECMWF to discuss the use of infrared brightness temperatures for model verification and data assimilation. Model developers at ECMWF have traditionally not used high-resolution satellite observations to assess the forecast accuracy. Instead, they have typically relied upon observation-minus-background departure statistics from the global data assimilation system to identify regions and situations where the model background errors are unusually large. They described a recent example where large errors identified in the data assimilation statistics helped them determine that the cloud microphysics scheme was not producing enough super-cooled liquid droplets during cold air outbreaks over mid-latitude regions. Subsequent modifications of parameters in the microphysics scheme substantially reduced the model error in these situations.



For visualization purposes, they currently create simulated brightness temperature images for select infrared bands that assume a nadir viewing geometry for all grid points. This approach is useful for qualitative evaluation of the forecasts because it creates seamless satellite imagery over the entire globe that is not dependent on the global constellation of satellite sensors. In other words, for qualitative assessments, it is easier to construct a single image with uniform viewing geometry across the entire globe than it is to compute the simulated brightness temperatures for each geostationary satellite sensor (which often have slightly different bands) and then stitch them into a single image. It is important to note however that the utility of these simulated satellite datasets will be more limited for quantitative verification because assuming nadir viewing geometry for all grid points will introduce biases in the statistics as the zenith angle increases. The capability does exist in their system though to generate simulated brightness temperatures containing the correct viewing geometry for a given satellite sensor. Regardless, observation-minus-background departure statistics from their data assimilation system have proven to be an effective means with which to identify biases in the model and to determine the impact of changes in the parameterization schemes to address these issues.

Many discussions were also held with data assimilation experts that together fostered a very useful exchange of ideas regarding optimal ways to assimilate information from all-sky infrared brightness temperatures. ECMWF has assimilated all-sky microwave observations for several years and is now turning their attention toward the assimilation of all-sky infrared observations. As such, there was a lot of interest in the nonlinear bias correction method that we recently developed that can remove both linear and nonlinear conditional biases from all-sky satellite brightness temperatures (Otkin et al. 2018). There was also interest in the observing system simulation experiments (OSSEs) that we have performed during the past several years that assessed the impact of assimilating all-sky GOES-R ABI infrared brightness temperatures in high-resolution models. Very useful discussions were held regarding development of new methods to define situation-dependent observation errors that build upon prior work assimilating all-sky microwave observations and also to identify suitable predictors that can be used to remove the bias from all-sky infrared observations prior to their assimilation. Predictors sensitive to the cloud top height currently appear to be the most promising candidates for both of these purposes.

Additional meetings were held with developers of the cloud microphysics scheme and RTTOV as well as with scientists exploring the assimilation of surface-sensitive satellite observations. All of these discussions were very useful.

### **Publications and Conference Reports**

Otkin, J. A., 2018: Using all-sky satellite infrared brightness temperatures for model verification and in ensemble data assimilation systems. *European Center for Medium-range Weather Forecasts (ECMWF) Seminar Series*, Reading, United Kingdom.

Otkin, J. A., 2018: Using all-sky satellite infrared brightness temperatures for model verification and in ensemble data assimilation systems. *Met Office Seminar Series*, Exeter, United Kingdom.

### **References**

Cintineo, R., J. A. Otkin, F. Kong, and M. Xue, 2014: Evaluating the accuracy of planetary boundary layer and cloud microphysical parameterization schemes in a convection-permitting ensemble using synthetic GOES-13 satellite observations. *Mon. Wea. Rev.*, **142**, 163-182.



Griffin, S. M., **J. A. Otkin**, C. M. Rozoff, J. M. Sieglaff, L. M. Counce, C. R. Alexander, T. L. Jensen, and J. K. Wolff, 2017: Seasonal analysis of cloud objects in the High Resolution Rapid Refresh (HRRR) model using object-based verification. *Mon. Wea. Rev.*, **56**, 2317-2334.

Griffin, S. M., **J. A. Otkin**, C. M. Rozoff, J. M. Sieglaff, L. M. Counce, and C. R. Alexander, 2017: Methods for comparing simulated and observed satellite infrared brightness temperatures and what do they tell us? *Wea. Forecasting*, **32**, 5-25.

**Otkin, J. A.**, R. Potthast, and A. Lawless, 2018: Nonlinear bias correction for satellite data assimilation using Taylor series polynomials. *Mon. Wea. Rev.*, **146**, 263-285.

**Otkin, J. A.**, W. E. Lewis, A. Lenzen, B. McNoldy, and S. Majumdar, 2017: Assessing the accuracy of the cloud and water vapor fields in the Hurricane WRF (HWRF) model using satellite infrared brightness temperatures. *Mon. Wea. Rev.*, **145**, 2027-2046.

## **14. Development of an Archival System for the Integration of High Resolution GOES-R, Radar, and Lightning Data for Improving Severe Weather Forecasting and Warning Capabilities**

**CIMSS Task Leader: Shane Hubbard**

**CIMSS Support Scientists: Wayne Feltz and Jun Li**

**NOAA/NESDIS/STAR Collaborators: Bob Rabin, Lans Rothfusz, Alan Gerard (NOAA/NSSL), Micheal Pavolonis (NOAA/STAR)**

**Collaborators: Anthony Reinhart, Thomas Jones (OU/CIMMS and NOAA/NSSL) and Dave Parsons, Chair, OU/School of Meteorology**

### **NOAA Long Term Goals:**

- Weather-Ready Nation

### **NOAA Strategic Goals:**

- Serve society's needs for weather and water
- Provide critical support for the NOAA mission

### **CIMSS Research Themes:**

- Satellite Meteorology Research and Applications

### **Project Overview**

The Geostationary Operational Environmental Satellite (R-Series; GOES-R) will provide coverage (spatially and temporally) that, particularly when integrated with ground-based systems such as WSR-88D radars, can actively support severe weather forecasting and warnings. With the launch of GOES-R, space-based and ground-based observations will be in cadence with each other, providing the ability to create a top to bottom, linked profile of a severe thunderstorm through direct observation. It is vitally important that stakeholders such as scientists at the National Severe Storms Laboratory (NSSL), developers integrated with the Storm Prediction Center, forecasters at various National Weather Service (NWS) offices, and training entities such as the Warning Decision Training Division (WDTD) have access to the GOES-R data to integrate the data into their current research, algorithm development, and training. All of this integration is critical to GOES-R support of a Weather Ready Nation.



This project will set up and maintain an archive of all of relevant GOES-R data related to severe and hazardous weather. This data will be available through open access and may be used by all interested parties with the goal of integration and development of severe weather applications and algorithms. This proposal not only outlines a plan for data archival, but also supports integration of this initial GOES-R data into these platforms.

## **Milestones with Summary of Accomplishments and Findings**

### ***Accomplishments:***

Milestone 1: The CIMSS team has purchased its staging server that intersects with the CIMSS team's archival server.

Milestone 2: Scripts have been developed that grab Level 1 and Level 2 GOES 16 data daily and places those into a FTP staging area whereby scripts developed by CIMSS can grab those datasets seamlessly. The scripts at CIMSS also roll the archive to maintain a 7-day storage area and data older than 7-days is then removed. By request, historic GOES 16 data can also be placed onto the server by request.

### ***In progress:***

Milestone 3: We have been working with NOAA scientist Bob Rabin to determine the best algorithm that fits the goals of this project for parallax correction. CIMSS will parallax correct L1 and L2 datasets prior to staging onto the CIMSS server for the ingestion of the CIMSS server.

Milestone 4: Verification of archived datasets, parallax corrections, and completeness will occur by UW-CIMSS.

### ***Beginning:***

Milestone 5: Initializing the quantification of the spatiotemporal development, maintenance, and dissipation of cloud top features in relationship to signals of severe weather at the surface (e.g., surface obs, radar detected severe weather)

We anticipate initial findings to occur within the next 3 – 4 months. The server is now up and running, data is flowing, and parallax corrections will be occurring soon. At this point we will begin to have the data necessary to accomplish intercomparisons of surface data, NEXRAD volumetric data, and cloud top features for severe weather events.

## **Publications and Conference Reports**

We anticipate conference participation in the fall of 2018 and spring of 2019.

## **References**

We expect peer reviewed publications in 2019.



## 15. SSEC/CIMSS Cloud Research in Support of the Suomi-NPP and JPSS Programs 2017

### 15.1 VIIRS Algorithm Development

**CIMSS Task Leader: Denis Botambekov**

**CIMSS Support Scientists: Andi Walther, Yue Li, Steve Wanzong**

**NOAA Collaborator: Andrew Heidinger**

**Budget: \$125,000**

#### NOAA Long Term Goals:

- Weather-Ready Nation

#### NOAA Strategic Goals:

- Serve society's needs for weather and water
- Understand climate variability and change to enhance society's ability to plan and respond
- Provide critical support for the NOAA mission

#### CIMSS Research Themes:

- Satellite Meteorology Research and Applications
- Satellite Sensors and Techniques

#### Objective

Development and support of all cloud algorithms for Sumi-NPP and JPSS programs are the main objectives of this project.

#### Project Overview

The team of scientists develops and supports two cloud masks for VIIRS on both S-NPP and NOAA-20 satellites: Enterprise Cloud Mask (ECM), which became operational and is produced by ASSISST NOAA STAR, and the VIIRS Cloud Mask (VCM) produced in the IDPS at NOAA. Both masks are using several tests to determine cloud occurrence at the each VIIRS pixel. The other cloud algorithms include the AWG Cloud Height Algorithm (ACHA), Daytime and VIIRS Nighttime Lunar Cloud Optical and Microphysical Properties (DCOMP and NLCOMP), and Cloud Base Height (CBH). Different developed tools are used to validate and tune the ECM, ACHA, DCOMP and NLCOMP. This is a collective effort and is coordinated with our colleagues from the Air Force Weather Agency (AFWA) in Omaha, Nebraska (Tom Kopp), NOAA STAR JPSS Algorithm Integration Team (AIT) (Walter Wolf), and Cooperative Institute for Research in the Atmosphere (CIRA) (Steve Miller).

#### Task List

- *Validation Tool Development*  
Our developed tools allow for the validation of the cloud algorithms produced globally and on individual granules.
- *NOAA/NASA Cloud Mask Comparison*  
Using our tools, we are able to compare other developed cloud masks to the ECM and VCM. These are run at the CIMSS in Madison, Wisconsin (UW). The tools allow us to create match-ups between ECM, VCM and MODIS (MYD35) cloud masks.
- *VIIRS Match-ups with CALIOP*  
Data from CALIPSO is considered as "truth". Matching CALIOP data with VIIRS allows us to validate and tune the algorithms. These tools run at the CIMSS in Madison,



Wisconsin (UW). The identified errors lead to a better understanding of cloud detection, and improves the cloud masks and cloud properties products.

### Milestones with Summary of Accomplishments and Findings

The recently launched JPSS-1, which after launch became NOAA-20, has started to produce data. The Cloud team is in the process of validating the cloud products. During this time period, there were two science code deliveries. One occurred in August 2017 and the other occurred in February 2018. In between the two science code updates, there were several science code and lookup table updates. For example, the DCOMP algorithm was updated in the SAPF (operational processing system) to match the current code in the offline processing system (CLAVR-x). In addition, as part of the August 2017 delivery, sensor specific lookup tables for NOAA-20 were delivered for the DCOMP and NCOMP algorithms. Currently, the April 2017 algorithms are running in the operational string at NDE for S-NPP and the August 2017 science code is running in the Integration and Testing (I&T) string at NDE on NOAA-20. Data from the I&T string will be used by the Cloud team for the upcoming beta and provisional reviews.

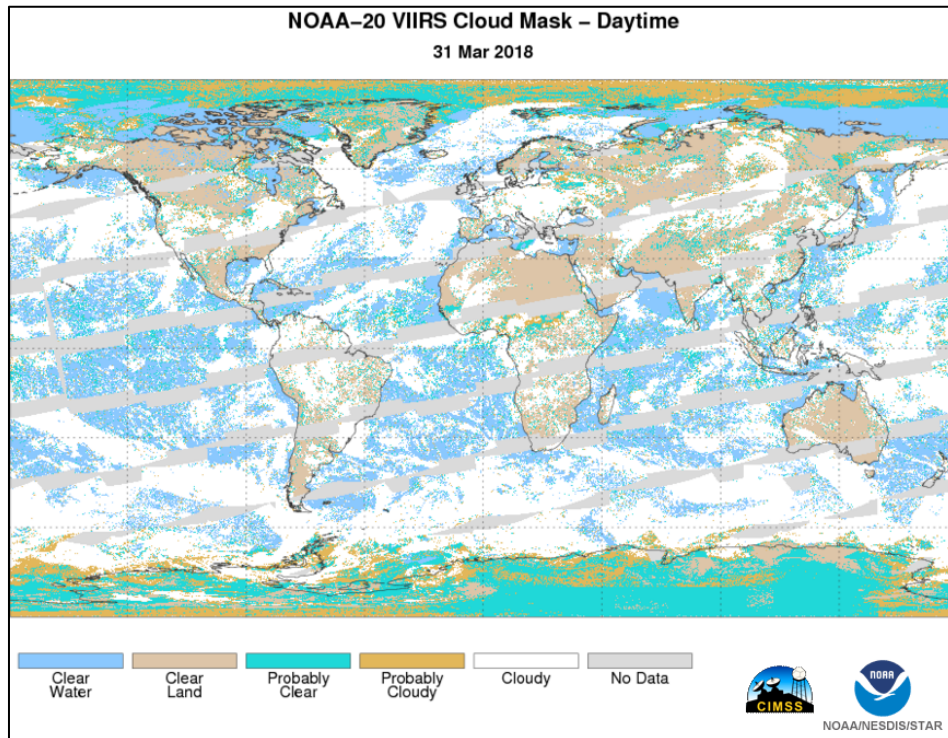

Figure 48. Enterprise Cloud Mask (ECM), NOAA-20 VIIRS, 2018-03-31.

(These NOAA-20 data are preliminary, non-operational data and are undergoing testing. Users bear all responsibility for inspecting the data prior to use, and for the manner in which the data are utilized).

The ECM Beta review originally was scheduled for June, 2018, but the Program Office asked to move it to the end of April, 2018. Figure 48 shows a full day of NOAA-20 VIIRS ECM. Despite some issues like missing files (grey areas on the image), which is been worked on by the Ground Processing team and PDA, the ECM looks reasonable. It is anticipated that despite all of these issues, the performance of the Enterprise Cloud Mask will be acceptable to meet the Beta review criteria.

A new manual analysis tool for VIIRS Cloud Mask has been developed by AFWA, which allows overlying of Cloud Mask results over a single channel or RGB combination to distinguish clouds



from the surface snow and other features. See Figure 49 for an example of the Manual Analysis Tool.

- The new tool allows for manual “truth” to be derived from any VIIRS granule, allowing for quantitative validation over any desired scene.
- It will also allow for quantitative evaluation for any ECM update.
- The tool will also mimic the prior VCM visualization tool in that it will also allow a user to visualize individual cloud test outputs.
  - Visualizing ECM output will be independent of the manual analysis tool such that the manual analysis can be performed without the analyst being aware of the ECM results.

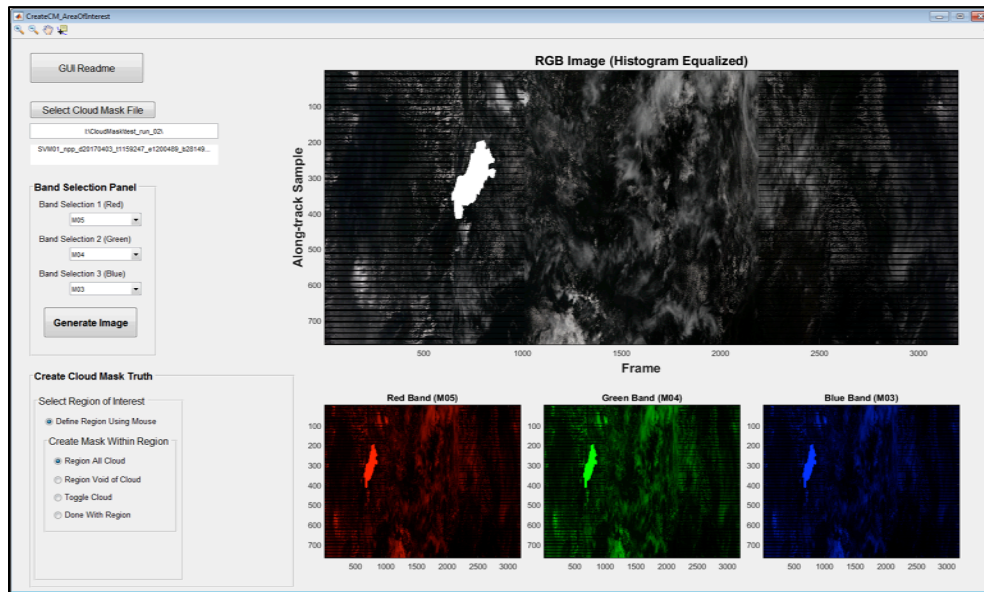

Figure 49. Sample of ECM (VCM) Manual Analysis Tool.

## 15.2 Software/Algorithm Integration and Testing

**CIMSS Task Leader: William Straka III**

**CIMSS Support Scientist: Jay Hoffman**

**NOAA Collaborators: Andrew Heidinger, Michael Pavolonis**

**Budget: \$38,000**

### NOAA Long Term Goals:

- Weather-Ready Nation

### NOAA Strategic Goals:

- Serve society’s needs for weather and water
- Support the nation’s commerce with information for safe, efficient and environmentally sound transportation
- Provide critical support for the NOAA mission

### CIMSS Research Themes:

- Satellite Meteorology Research and Applications
- Satellite Sensors and Techniques



## **Objective**

To develop and integrate the Cloud Base and Cloud Cover Layers (CCL) algorithms in to the STAR Algorithm Processing Framework.

## **Project Overview**

The NOAA NDE algorithms (enterprise cloud algorithms) are integrated into the STAR Algorithm Processing Framework (SAPF), which is the NDE equivalent of the IDPS. The CIMSS Cloud team views the ability to run the SAPF locally as a critical part of the development and maintenance tasks. The development and maintenance of bridge code allows algorithm tests in both the local processing framework (CLAVR-x) as well as the operational processing framework (SAPF). Being able to perform algorithm tests in multiple frameworks is a critical step in preserving product performance from research to operations.

## **Milestones and Summary of Accomplishments and Findings**

The focus of the JPSS Cloud AWG this reporting period was maintaining and updating the various cloud algorithms, validating the updated algorithms for Suomi-NPP and NOAA-20. The tasks for this project were to develop and integrate the Cloud Base and Cloud Cover Layers (CCL) algorithms in to the SAPF. In order to do this, new bridges must be developed for new algorithms, such as the evolution of CCL into a standalone algorithm. In addition, as algorithms evolve, new inputs and outputs may be developed - which would require the maintenance of the existing bridge/services modules for those algorithms. Each year, the algorithm teams have two standard deliveries, one at the beginning, and the second in middle of each year. Part of the current years projects included updating DCOMP to the latest science as well as ensuring the algorithms were able to run on NOAA-20. These updates were successfully delivered at the beginning of 2018, with an anticipated transition to operations by the end of 2018. During this time, the teams will be validating the algorithms as part of the verification for beta and provisional maturity of the algorithms.

In order to ensure the integrity of the integration of the cloud algorithms, as well as providing output in order to tune and maintain the algorithm, the Cloud team developed the ability to run the SAPF independently. This involved the installation of the latest versions of AIT Framework on local CIMSS machines and developing the infrastructure to process numerous days of granules through cluster processing. The amount of processing time, illustrated in Figure 50, decreases dramatically with increasing number of processing cores. To process a day of VIIRS data would take longer than a day if processed linearly, however process tens of granules simultaneously allows a day of VIIRS data to be processed in a fraction of an hour. This was needed in order to support both algorithm integration and validation efforts as well as the development of thresholds specific to the SAPF.



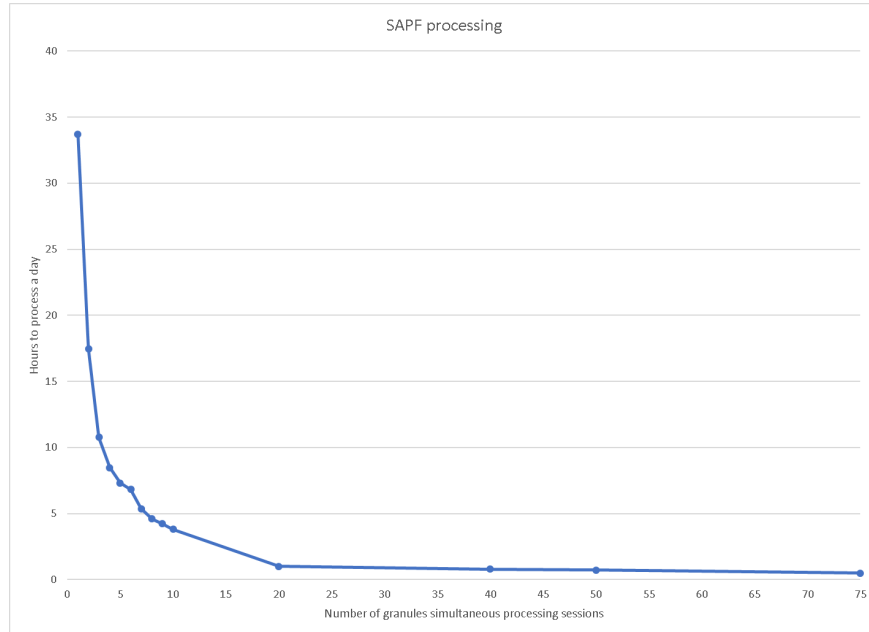

Figure 50. Processing time in number of hours to process a day of VIIRS data as a function of processing cores.

### 15.3 Software/Algorithm Maintenance

**CIMSS Task Leader: William Straka III**

**CIMSS Support Scientists: Corey Calvert, Yue Li, Andi Walther, Pat Heck, Denis Botambekov, Steve Wanzong**

**NOAA Collaborators: Andrew Heidinger, Michael Pavolonis**

**Budget: \$97,000**

#### NOAA Long Term Goals:

- Weather-Ready Nation

#### NOAA Strategic Goals:

- Serve society's needs for weather and water
- Support the nation's commerce with information for safe, efficient and environmentally sound transportation
- Provide critical support for the NOAA mission

#### CIMSS Research Themes:

- Satellite Meteorology Research and Applications
- Satellite Sensors and Techniques

#### Objective

Maintaining cloud products as required for the JPSS program.

#### Project Overview

This project requires that cloud products are maintained to insure that they meet the requirements set in the JPSS LIRD. This includes retuning algorithms using a sufficient amount of data from the operational processing system (the SAPF), delivering updates of the science code as improvements are made, and delivering updated documentation to support NDE operations. In

addition, supporting the JPSS EDR monitoring site, JPSS PG, CSPP, and participating in science and user interaction meetings are part of this task.

### Milestones and Summary of Accomplishments and Findings

During this time period, the CIMSS Cloud team updated the cloud algorithms (Mask, type, height, base and COMP) twice. As part of this process, the statistics from the algorithm were compared to truth (ex. CALIOP) as well as to offline (CLAVR-x) comparison with truth data. In Figure 51, the differences of Cloud Top Height (CTH) retrievals between SAPF and truth are shown. Also plotted are the retrievals from CLAVR-x and truth. With phase matching and single layer filtering, which rule out the differences caused by preceding cloud type algorithms, the distributions are very close. The observed differences are mostly due to use of different radiative transfer models and ancillary data.

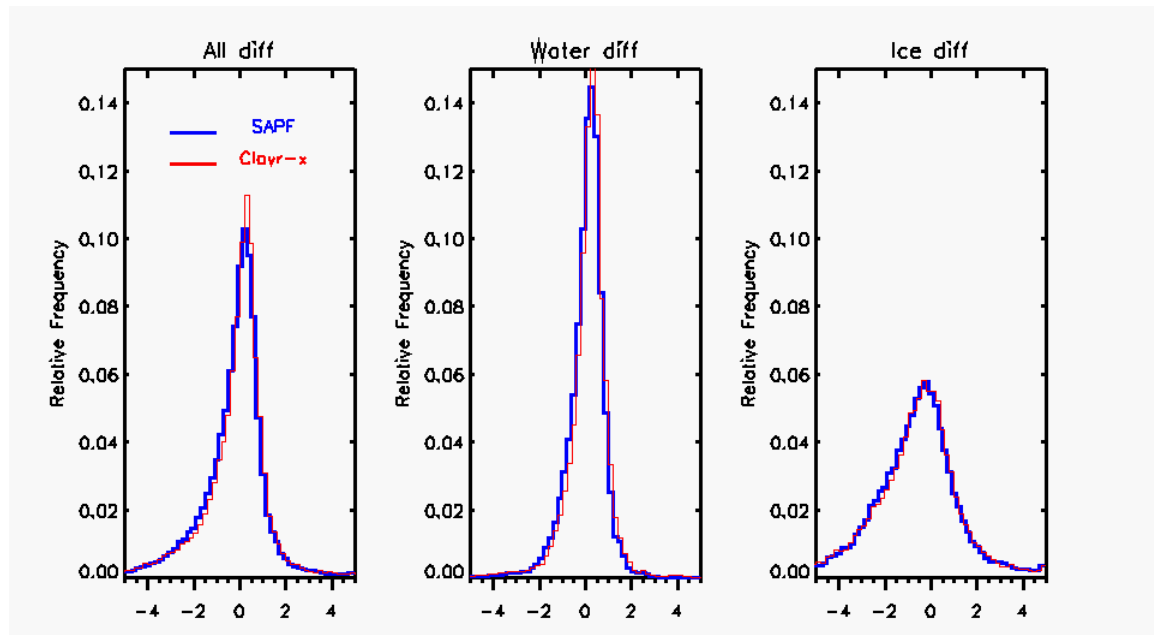
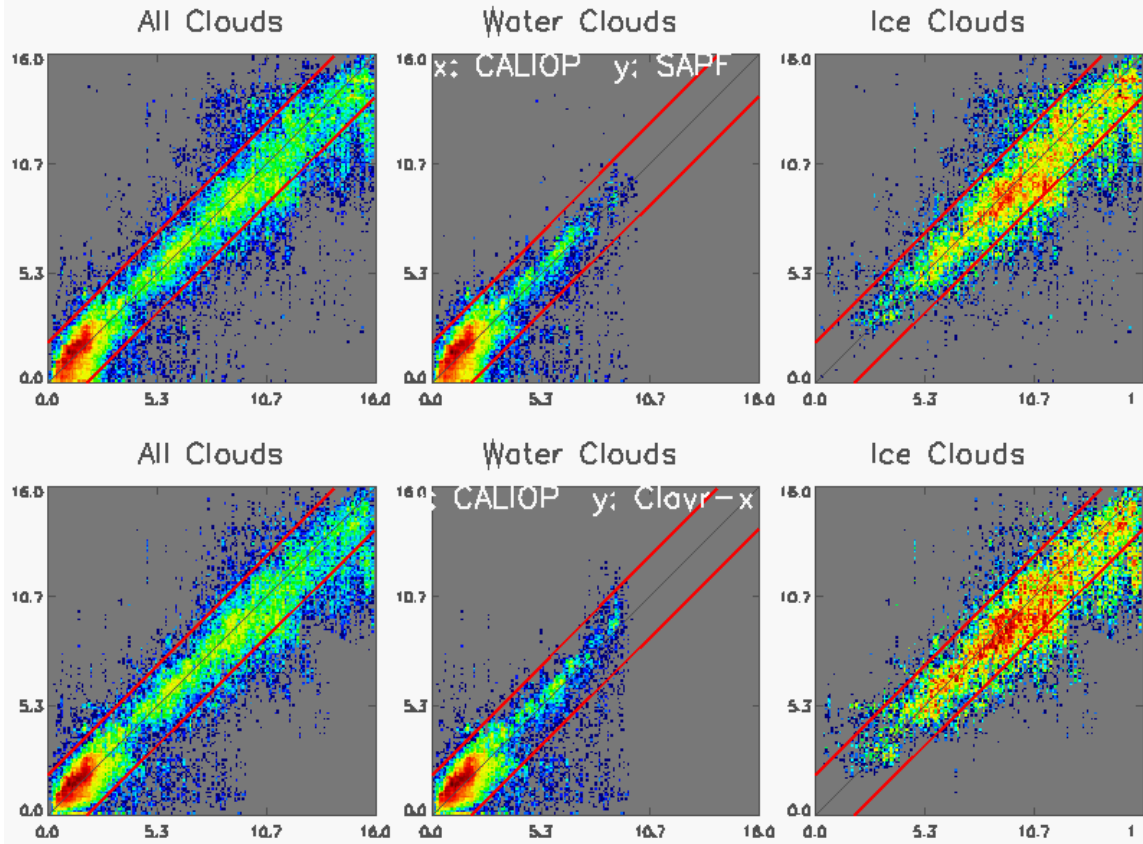

Figure 51. Histogram Distribution of differences between NPP VIIRS and CALIPSO/CALIOP. Phase matching and single layer filtering is applied. One day data (01/03/2015) are used.

As can be seen the histogram distributions show close agreement between SAPF and CLAVR-x (offline) tests. Further analysis shows that the algorithms have similar performances for all cloud types (Figure 52). This figure shows that retrievals meet the specification requirements for most pixels and is similar to previous analysis done when comparing CLAVR-x and SAPF output.



**Figure 52. Scatter plots of phase-matched single layer cloud top heights between CALIPSO/CALIOP and SAPF (up) and CLAVR-x (bottom). Same data are used as in Figure 51. The red line is the specification requirement from JPSS LIRD.**

Figure 53 shows the validation of the SAPF cloud base height against CloudSat products. This figure indicates that the cloud base height retrieval algorithm performs well except for the top left part, where retrievals overestimate the cloud base heights. This mostly occurs in thick cloud optical thickness (COT) regions and for a few cirrus types. The performance has been improved in the latest update delivery (Feb 2018) to NOAA ASSISTT.

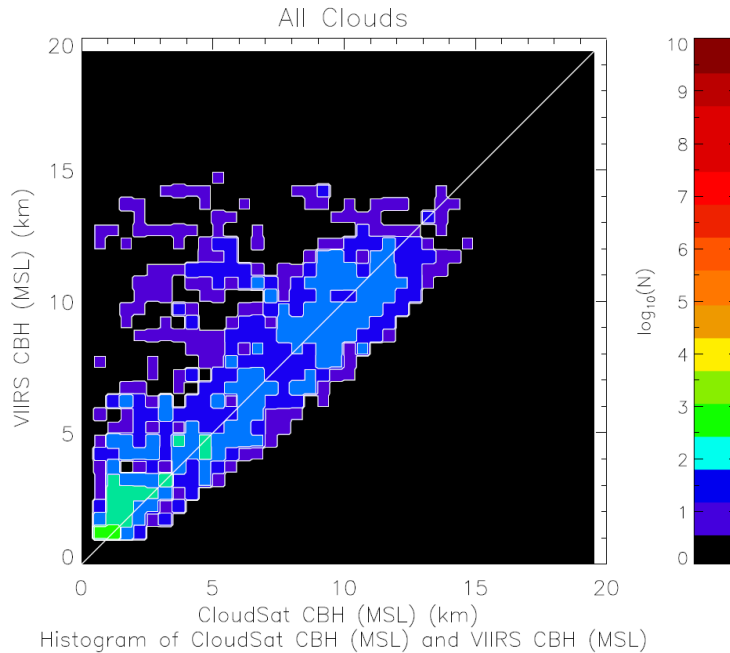

**Figure 53. Scatter plots of cloud base heights between VIIRS from SAPF and CloudSat. Only pixels with CTH within 1km of CloudSat CTH if COT > 1, or within 2km if COT < 1 are included.**

In addition to the science code, updated ATBDs and lookup tables were delivered for algorithms which require sensor specific information.

#### 15.4 Calibration and Validation

**CIMSS Task Leader: Denis Botambekov**

**CIMSS Support Scientists: Andi Walther, Yue Li, Steve Wanzong**

**NOAA Collaborator: Andrew Heidinger**

**Budget: \$76,000**

#### NOAA Long Term Goals:

- Weather-Ready Nation

#### NOAA Strategic Goals:

- Serve society's needs for weather and water
- Understand climate variability and change to enhance society's ability to plan and respond
- Provide critical support for the NOAA mission

#### CIMSS Research Themes:

- Satellite Meteorology Research and Applications
- Satellite Sensors and Techniques

#### Objective

To validate and calibrate cloud algorithms run on VIIRS data for the JPSS Program is the main objective of this project.



## Project Overview

The CIMSS cloud team has developed cloud algorithms that are the official products of NOAA STAR. Cloud algorithms include the Enterprise Cloud Mask (ECM), AWG Cloud Height Algorithm (ACHA), Daytime and Nighttime Lunar Cloud Optical and Microphysical Properties (DCOMP and NLCOMP), and Cloud Base Height (CBH). All of these products are validated against other existing cloud algorithms. There are different tools that are used to validate and calibrate cloud algorithms. We work closely with other colleagues from the Air Force Weather Agency (AFWA) in Omaha, Nebraska (Tom Kopp), NOAA STAR JPSS Algorithm Integration Team (AIT) (Walter Wolf), and Cooperative Institute for Research in the Atmosphere (CIRA) (Steve Miller).

### *Task List*

- *Validation Tool Development*  
Our developed tools allow for the validation of all cloud algorithms produced globally and for individual granules.
- *Cloud Algorithms Comparison*  
Calibration and validation of our cloud algorithms is possible by comparing the results with the other developed algorithms. All of the tools are run at the CIMSS in Madison, Wisconsin (UW). The tools create match-ups between VIIRS and MODIS Aqua.
- *VIIRS Match-ups with CALIOP*  
Data from CALIPSO is considered as “truth.” Matching CALIOP data with VIIRS is another method for validating and calibrating the algorithms. These tools run at the CIMSS in Madison, Wisconsin (UW). The identified errors lead to better understanding of cloud detection, cloud optical properties and improving of the cloud algorithms.

## Milestones with Summary of Accomplishments and Findings

The CIMSS cloud team provides daily updates to the Long-Term Monitoring (LTM) website, which is maintained at CIMSS. The VIIRS cloud algorithms are run over the North Pacific off the California Coast, USA and Brazil, which are then compared to the MODIS-Aqua and AVHRR-NOAA19 (<http://cimss.ssec.wisc.edu/patmosx/VIIRS.html>). Figure 54 shows (a) SNPP-VIIRS RGB image, (b) SNPP-VIIRS Cloud Optical Depth (COD), (c) Aqua-MODIS COD, and (d) NOAA-19 AVHRR COD over the CONUS domain from April 1, 2018. Visually, VIIRS COD (b) is higher than AVHRR COD (d) and MODIS COD (c) by approximately 2-4%. The Atmosphere SIPS data from NASA has recalibrated the visible channels of VIIRS. At this moment the Cloud Team is re-processing data with new calibrated VIIRS channels. It is believed that reducing the reflectance of VIIRS M5 channel (0.65 micron) by approximately 5-6%, will allow the VIIRS COD be similar to the other instruments.

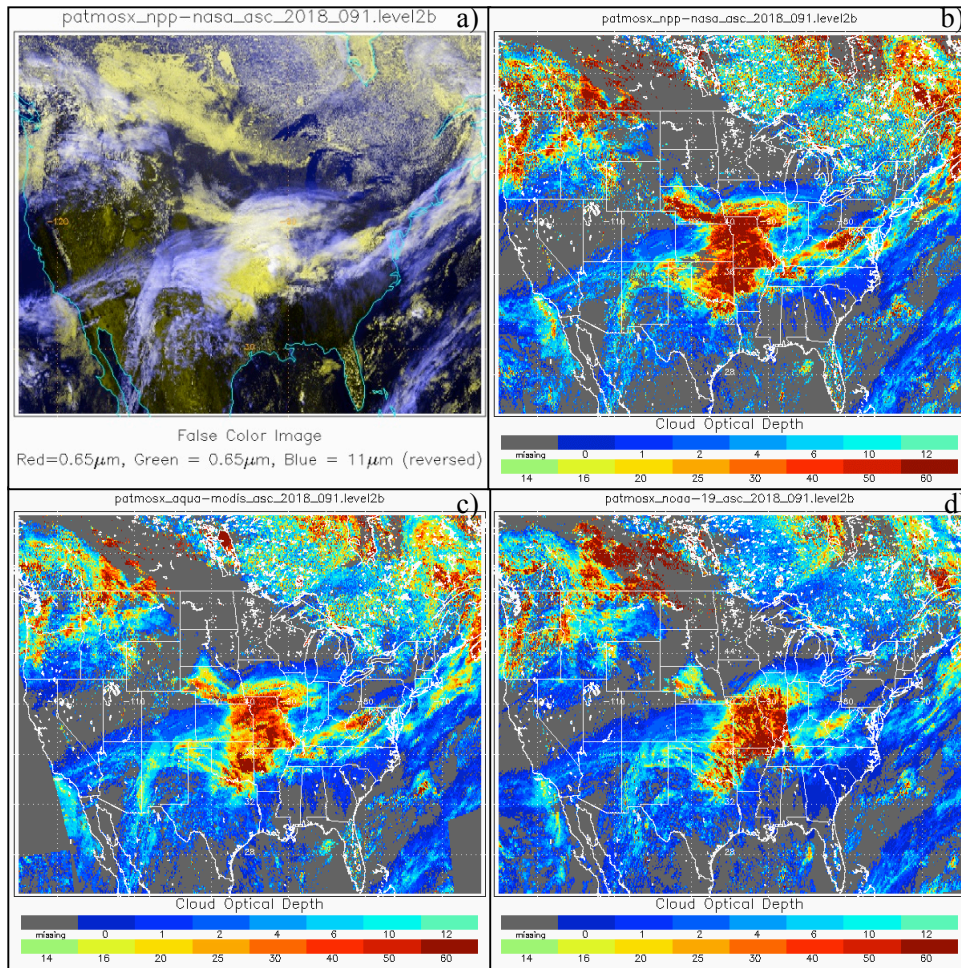

Figure 54. a) SNPP-VIIRS RGB, b) SNPP-VIIRS Cloud Optical Depth (COD), c) Aqua-MODIS COD d) NOAA-19 AVHRR COD over CONUS, 2018-04-01.

## 15.5 Long-Term Monitoring and Anomaly Resolution

CIMSS Task Leader: Michael Foster

CIMSS Support Scientist: Denis Botambekov

NOAA Collaborator: Andrew Heidinger

Budget: \$48,000

### NOAA Long Term Goals:

- Weather-Ready Nation

### NOAA Strategic Goals:

- Serve society's needs for weather and water
- Understand climate variability and change to enhance society's ability to plan and respond
- Provide critical support for the NOAA mission

### CIMSS Research Themes:

- Satellite Meteorology Research and Applications
- Satellite Sensors and Techniques



## Objective

Our primary objective is to ensure the quality and consistency of the Suomi NPP and JPSS VIIRS-derived cloud products and radiances through long-term monitoring and comparison against other satellite-based cloud products.

## Project Overview

The basic goals of this project are as follows:

- Implement a complete processing of the global VIIRS record using the NOAA Enterprise algorithms in CLAVR-x;
- Generate these data and images and deliver them to STAR for use in the STAR JPSS Product monitoring site: ([http://www.star.nesdis.noaa.gov/jpss/EDRs/products\\_clouds.php](http://www.star.nesdis.noaa.gov/jpss/EDRs/products_clouds.php)); and
- Establish an LTM site at CIMSS to monitor and validate VIIRS-derived cloud mask, cloud height, optical properties and valid pixel retrievals along with a method to monitor differences in calibration.

## Milestones with Summary of Accomplishments and Findings

Processing of the VIIRS data through CLAVR-x and delivery of data and imagery to STAR was accomplished during previous periods-of-performance. Figure 55 shows an example of a daily Daytime RGB image currently being produced at CIMSS and delivered to STAR. During this period of performance the tools for generating these images were modified in preparation for the launch of NOAA-20. These tools were then delivered to STAR with the goal of generating and publishing these images on-site. This process of transferring image generation from CIMSS to STAR is ongoing.

A CIMSS website was also developed as part of this project and is located at (<https://cimss.ssec.wisc.edu/patmosx/monitor.html>). The goal of this site is monitoring the number of valid VIIRS pixels, validate against other cloud mask, height, and optical retrieval products, and assess the quality of clear-sky radiances. To date comparisons are done using radiances and cloud products derived from Suomi NPP VIIRS, Aqua MODIS, and NOAA-19 AVHRR. This year work has been done to incorporate a new VIIRS-derived cloud product into these comparisons. The product, named MODAWG, is run at the Atmospheric SIPS at CIMSS and is the result of a collaborative effort between the NOAA CLAVR-x and NASA MODIS EOS processing groups. MODAWG processes VIIRS with a NASA-derived visible calibration and should provide new insights as to the causes of observed differences among the various cloud products. Data for comparison is currently being processed at the SIPS.



**Suomi NPP VIIRS False Color RGB - Daytime**  
**2 Apr 2018**

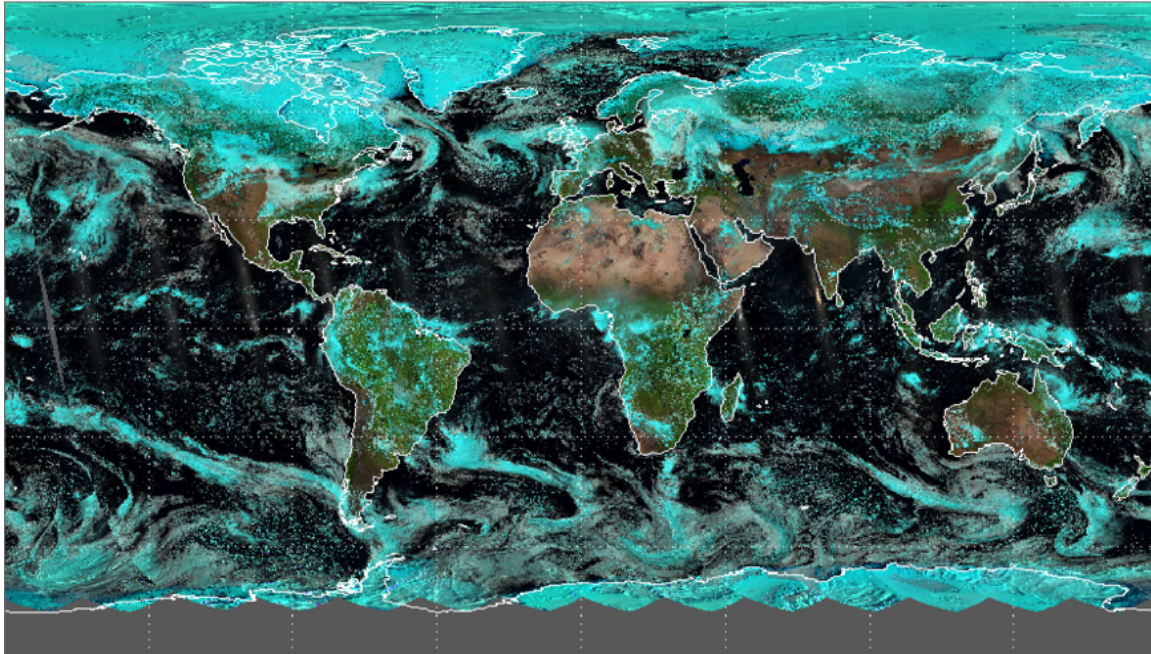

NOAA/NESDIS/STAR

Figure 55. Example of the imagery delivered to NOAA/NESDIS/STAR for monitoring. This and other imagery can be found at [http://www.star.nesdis.noaa.gov/jps/EDRs/products\\_clouds.php](http://www.star.nesdis.noaa.gov/jps/EDRs/products_clouds.php).

### 15.6 McIDAS Support for VIIRS Imagery and Data Analysis

**CIMSS Task Leaders: Tommy Jasmin, Dave Santek**

**NOAA Collaborator: Don Hillger (RAMMB/CIRA)**

#### **NOAA Long Term Goals:**

- Climate Adaptation and Mitigation
- Weather-Ready Nation

#### **NOAA Strategic Goals:**

- Serve society's needs for weather and water
- Understand climate variability and change to enhance society's ability to plan and respond
- Provide critical support for the NOAA mission

#### **CIMSS Research Themes:**

- Satellite Meteorology Research and Applications
- Satellite Sensors and Techniques
- Environmental Models and Data Assimilation
- Education and Outreach





## Objective

To support visualization and analysis of Suomi NPP and future JPSS data in McIDAS-V.

## Project Overview

Prior to launch, SSEC/CIMSS added support for visualization and analysis of Suomi NPP data in McIDAS-V. Code was developed to support the VIIRS, CrIS, and ATMS instruments. A user interface was introduced allowing aggregation of multiple consecutive granules into a single data selection, greatly improving ease of use. In 2017, the Suomi NPP Data Chooser was generalized and renamed to support all JPSS series satellites. This functionality was proven correct and robust after the November 18<sup>th</sup> launch of JPSS-1 (now renamed NOAA-20), once data products became available to the general public. New JPSS scripting methods were added, and existing methods improved, for the Jython scripting interface. Imagery can now be created entirely by McIDAS-V background scripts.

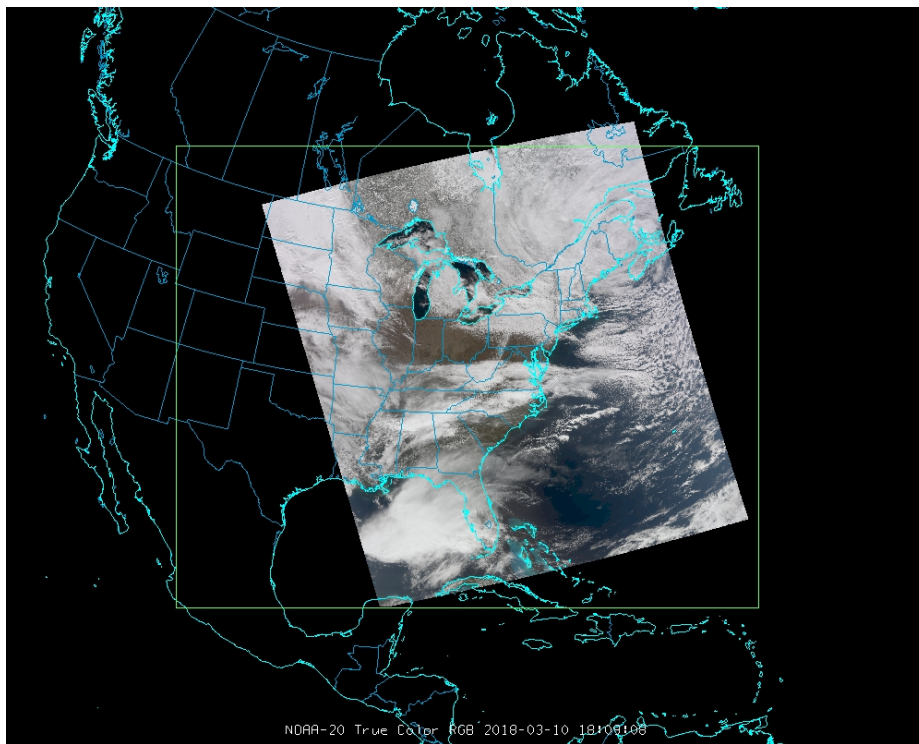

Figure 56. NOAA-20 VIIRS RGB, rendered via a McIDAS-V background script.

## Milestones with Summary of Accomplishments and Findings

With the launch of JPSS-1 in November 2017, it was vital to ensure McIDAS-V worked with NOAA-20 VIIRS SDR and EDR data once it became available. The primary VIIRS-related McIDAS-V goals for 2018 will be to resolve high priority feature requests and bug reports in time for the next stable McIDAS-V release, version 1.8. Some of the tasks outlined below were originally scheduled for 2017, but were pre-empted by preparation and development needed to support the launch of JPSS-1, and the visualization and analysis of its new data products.

### **Additional Planned Development for 2018**

- *Improve data selection user interface for swath data.*  
At present, it is very difficult to select an entire data granule or aggregation of data granules, and there is no option to specify a sample/stride for data. We will attempt to add these



capabilities in 2018.

- *Finish scripting development to facilitate user-driven derived product creation and background processing.*

Several users, including members of the NESDIS/StAR VIIRS Imagery Team, have expressed a need to utilize McIDAS-V capabilities with VIIRS data in a background environment. For example, to access data, run processing algorithms, and create output products. SSEC has developed this functionality via the Jython scripting interface. It is available now in the McIDAS-V nightly build, but requires further testing and enhancements prior to the next stable release.

- *Expand I/O conversion options.*

At present, users can load Suomi NPP data and write KMZ (which can be loaded, for example, in Google Earth). Users have expressed interest in being able to write Satellite-CF compliant NetCDF files, and GeoTIFF files. As standards for satellite data are now emerging, swath data can be gridded and output using the current CF standards. We will explore using this process for volume visualization of CrIS retrievals.

- *Handle visualization of low-Earth orbit (granule-based) data crossing the 180-degree longitude line.*

Currently, McIDAS-V has issues with swath data that straddles the International Date Line. The problem typically manifests as small pieces of missing data in the display for these granules, and is a serious deficiency for McIDAS-V when working with data near the poles.

## **16. SSEC/CIMSS Research Tasks in Support of the SuomiNPP and Joint Polar Satellite System (JPSS) Sensor Data Records**

### **16.1 A Broad Scope of Calibration/Validation and Independent Verification and Validation Activities in Support of JPSS, with Emphasis on CrIS SDRs**

**CIMSS Task Leader: David Tobin**

**CIMSS Support Scientists: Hank Revercomb, Robert Knuteson, Joe Taylor, Daniel DeSlover, Lori Borg, Michelle Feltz**

**NOAA Collaborators: Yong Chen, Changyong Cao**

**Budget: \$500,000**

#### **NOAA Long Term Goals:**

- Weather-Ready Nation

#### **NOAA Strategic Goals:**

- Serve society's needs for weather and water
- Understand climate variability and change to enhance society's ability to plan and respond
- Provide critical support for the NOAA mission

#### **CIMSS Research Themes:**

- Satellite Meteorology Research and Applications
- Satellite Sensors and Techniques

#### **Objective**

One of many objectives of this work was to participate in the early post-launch cal/val of JPSS-1 CrIS, and in particular to refine the radiometric nonlinearity coefficients based on the post-launch characterization.



## Project Overview

For the past period of performance, efforts of this project have focused on following main areas:

1. Support of CrIS related reviews and meetings
2. Continued Cal/Val analyses of the Suomi-NPP CrIS data
3. CrIS SDR algorithm assessment and refinement
4. Continued analysis of the JPSS-1 TVAC CrIS test data including involvement in the April 2017 Spacecraft level re-testing and data analysis
5. Involvement in the early post-launch evaluation of JPSS-1 CrIS data

## Milestones with Summary of Accomplishments and Findings

Progress for this project has been provided in quarterly progress reports over the past year. Topics have included:

- S-NPP CrIS FOV5 Anomaly Diagnosis and Correction Assessment;
- S-NPP CrIS Polarization Correction Assessment, including delivery of correction algorithm and coefficients;
- Development of an Interferogram Domain Self-apodization Correction for CrIS;
- Clear sky observed minus calculated for spectral ringing assessment;
- Suomi-NPP FIR Convolution Correction;
- Development of a “ILS Responsivity Correction” (for removing ILS dependency on responsivity);
- Dependence of Satellite Soundings on Instrument Field-of-View Size;
- S-NPP CrIS/VIIRS radiance comparisons; and
- Post-launch Cal/Val analyses of the JPSS1/NOAA20 CrIS on-orbit data, with focus on spectral and radiometric calibration to support Beta and Provisional Maturity.

The following is a summary of efforts starting 2014 with the TVAC testing of JPSS-1 CrIS through early 2018 with the initial on-orbit cal/val of JPSS-1 CrIS, with material covering the overall radiometric calibration and nonlinearity characterization and coefficient refinements. This was a major part of reaching beta and provisional maturity of the SDR product. This effort has provided a robust and traceable analysis of the CrIS calibration from TVAC to In-orbit for the creation of high quality radiance spectra that are already being used for weather and climate applications.

“For-score” thermal vacuum testing of JPSS-1 CrIS for Mission Nominal conditions took place in October 2014. For radiometric calibration, the primary factors to characterize were the performance of the Internal Calibration Target (ICT, aka blackbody), the radiometric nonlinearity, and small polarization effects. A test within the TVAC environment was not available to be performed for the polarization effects of JPSS-1 CrIS (however we are advocating for such tests to be performed for J2-4) and these effects are being characterized with the pitch maneuver data collected shortly after launch. For the ICT radiance and the nonlinearity, the primary results are shown in Figure 57 and Figure 58, which show the brightness temperature differences between CrIS calibration spectra and those predicted when viewing the External Calibration Target (ECT) over a range of six scene temperatures. The ECT provides the overall ground calibration reference for CrIS, and was subsequently measured by the NIST TXR to establish its temperature and emissivity characteristics. Figure 57 shows the residuals with no nonlinearity corrections, and Figure 58 shows the results with nonlinearity corrections in place and with the coefficients tuned to give optical agreement with the ECT view radiances. This tuning establishes the overall accuracy of the nonlinearity corrections and also creates optimal agreement among the nine CrIS FOVs per band.

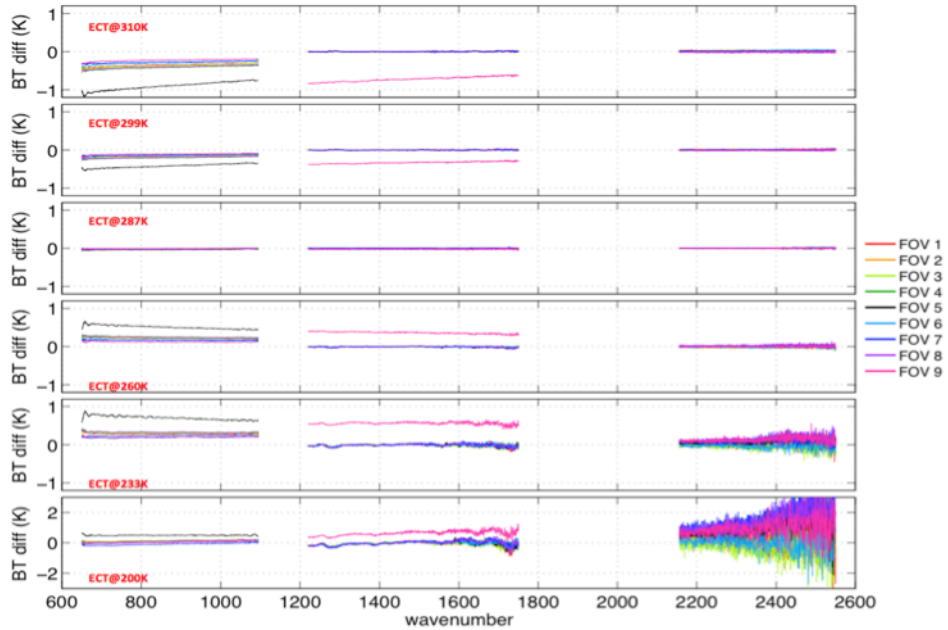

Figure 57. JPSS-1 CrIS thermal vacuum results comparing the calibrated radiance of each OFV against the "known" brightness temperature of the External Calibration Target (ECT). Without radiometric nonlinearity corrections.

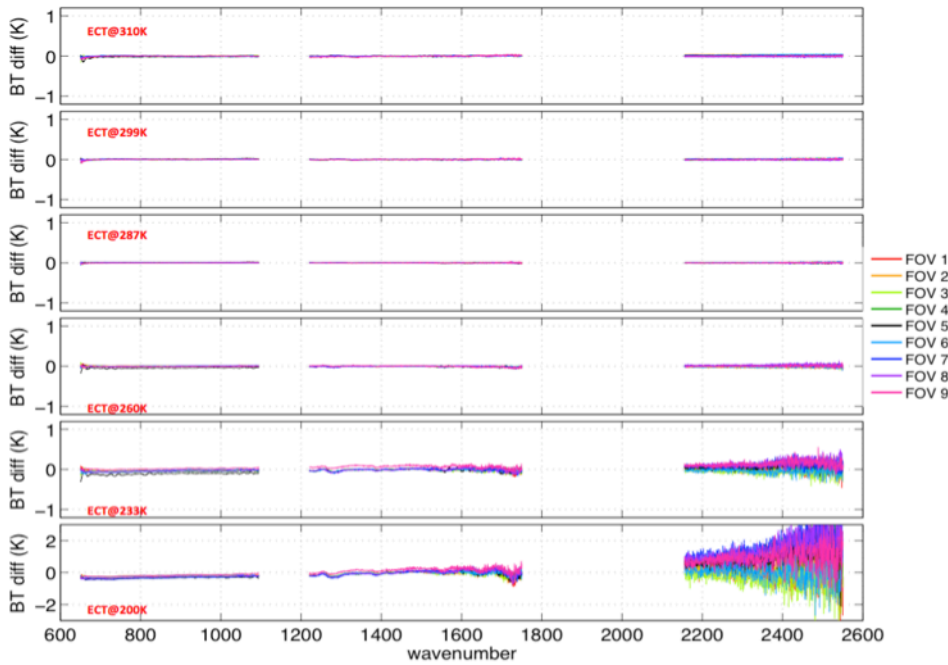

Figure 58. The same as Figure 57 but including radiometric nonlinearity corrections, and with nonlinearity coefficients (a2) tuned to give optimal agreement with the ECT view radiance.

Coincident with the ECT view data collection, Diagnostic Mode data which bypasses the on-board filtering and decimation process, and retains the full band-width of the CrIS spectra, was also collected in the October 2014 TVAC. This provides an independent way to also assess out-of-band signals related to various characteristics of the measurements including radiometric nonlinearity. As seen with S-NPP CrIS and throughout various phases of the JPSS-1 CrIS testing,



the nonlinearity of some detectors have changed with warm-up and cool-down of the detectors, and this Diagnostic Mode data provides a means to estimate the changes without the need for additional reference ECT measurements which are not available on-orbit. Jumping ahead to the on-orbit check-out of JPSS-1 CrIS in early 2018, we again collected Diagnostic Mode data to assess the nonlinearity. The progression of nonlinearity coefficients from TVAC to on-orbit are shown in Figure 59. The red values are those determined from the October 2014 ECT view tests, while the green values reflect the changes inferred from the DM data from TVAC to in-orbit. Overall for the LW detectors, there was a slight increase in nonlinearity indicated by the DM out-of-band signals, and a very large increase (85 percent) in the nonlinearity of MW FOV number 9. Following the DM analysis, we further tuned the  $a_2$  values to create optimal consistency among Earth view brightness temperature spectra observed among the nine FOVs/detectors; these are the final blue values, which when used in the ground calibration algorithms produce spectra which are consistent to better than 0.1K. An example of this progression is shown for the LW band in Figure 60 and for the MW band in Figure 61.

For the characterization of the JPSS-1 CrIS polarization behavior, we are using the pitch maneuver data collected on 31 January 2018 where deep space was viewed for the full range of scan angles. The calibrated spectra for this portion of the pitch maneuver are shown in Figure 62, without polarization correction, and the change in radiance across the swath is indicative of the scan dependent polarization effects that are being used to derive the polarization coefficients.

Other recent efforts related to JPSS-1 CrIS include: 1) analysis and assessments leading to the on-orbit determination of the inter-FOV spectral calibration performance and optimal ILS parameters, 2) NEDN performance assessments, 3) spectral and radiometric performance assessments using various cal/val techniques including clear sky obs/calc comparisons, SNO comparisons with IASI, and comparisons of CrIS and VIIRS.

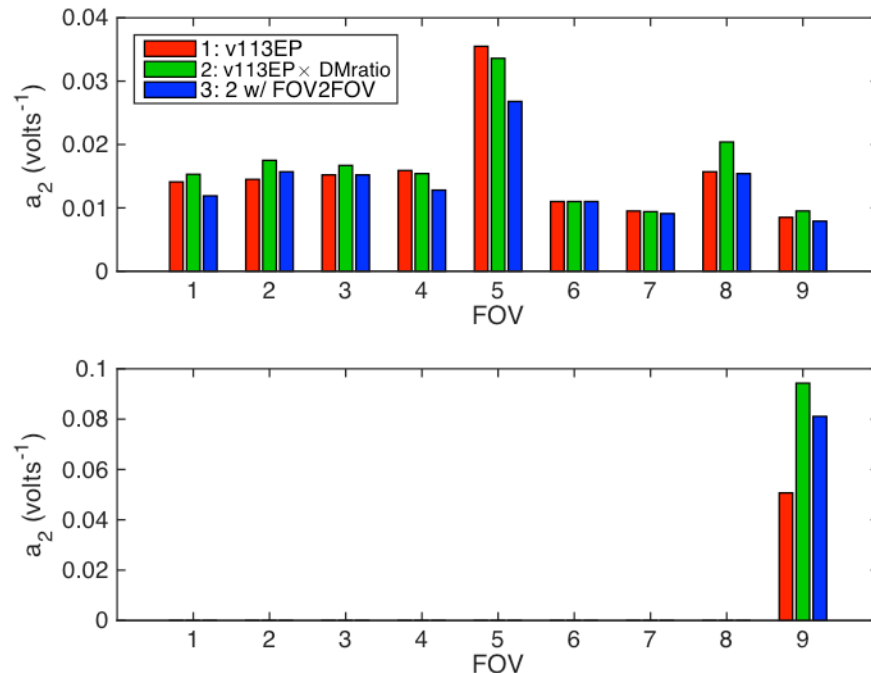

Figure 59. JPSS-1 nonlinearity coefficients,  $a_2$ , for the LW (top panel) and MW (bottom panel) FOVs/detectors.

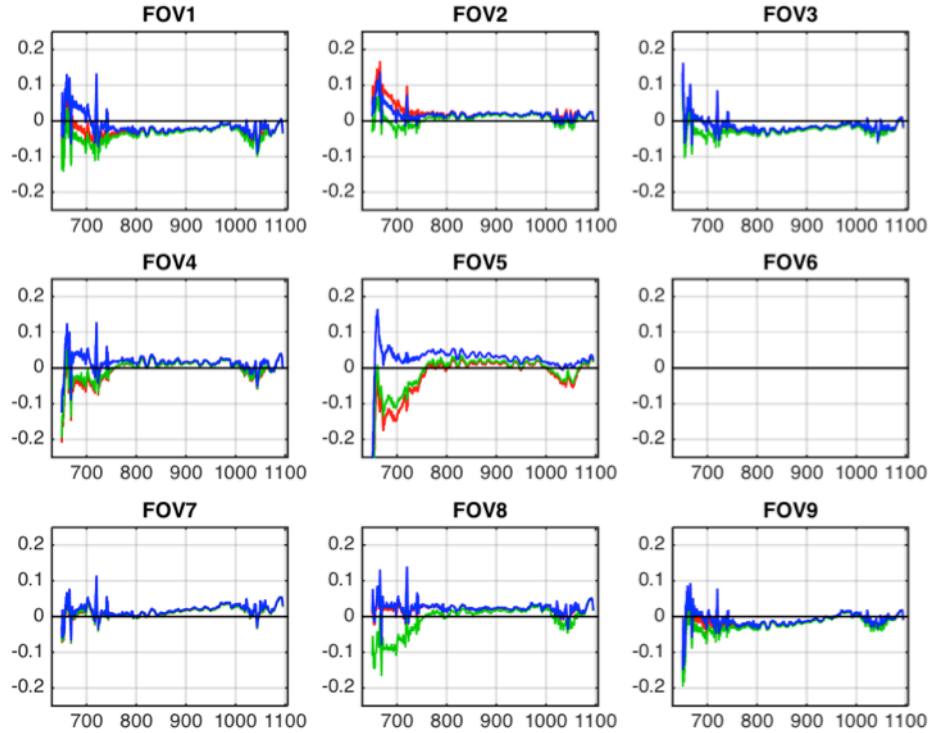

Figure 60. Earth view brightness temperature differences from the LW reference FOV6 for JPSS-1 CrIS LW detectors/FOVs. The red, green, and blue residuals correspond to the sets of  $a_2$  values shown in Figure 59.

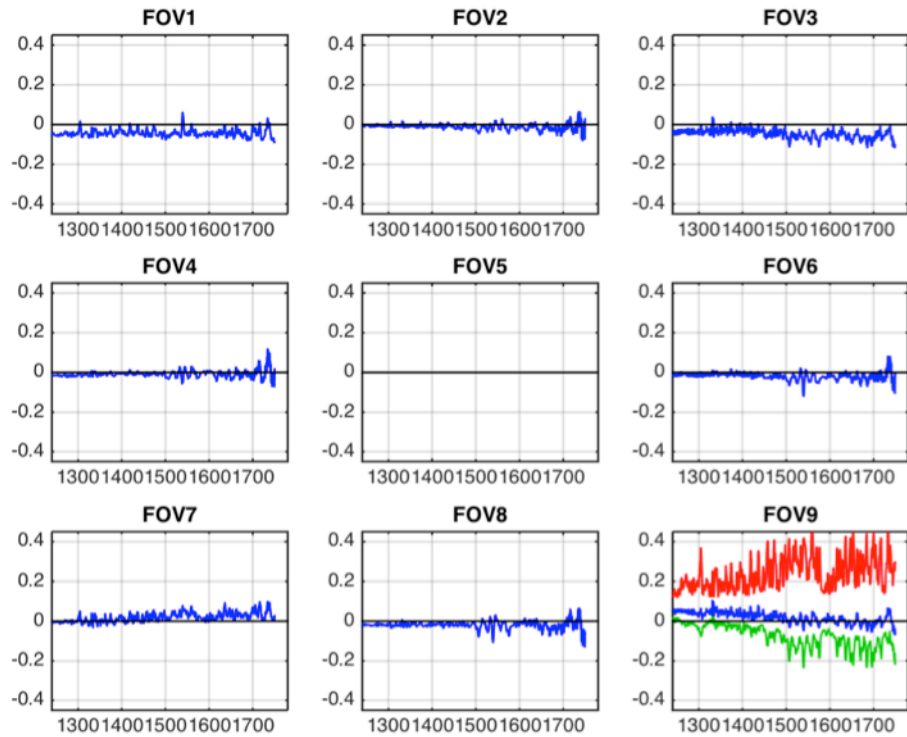

Figure 61. The same as Figure 60 but for the MW band and using MW reference FOV5.

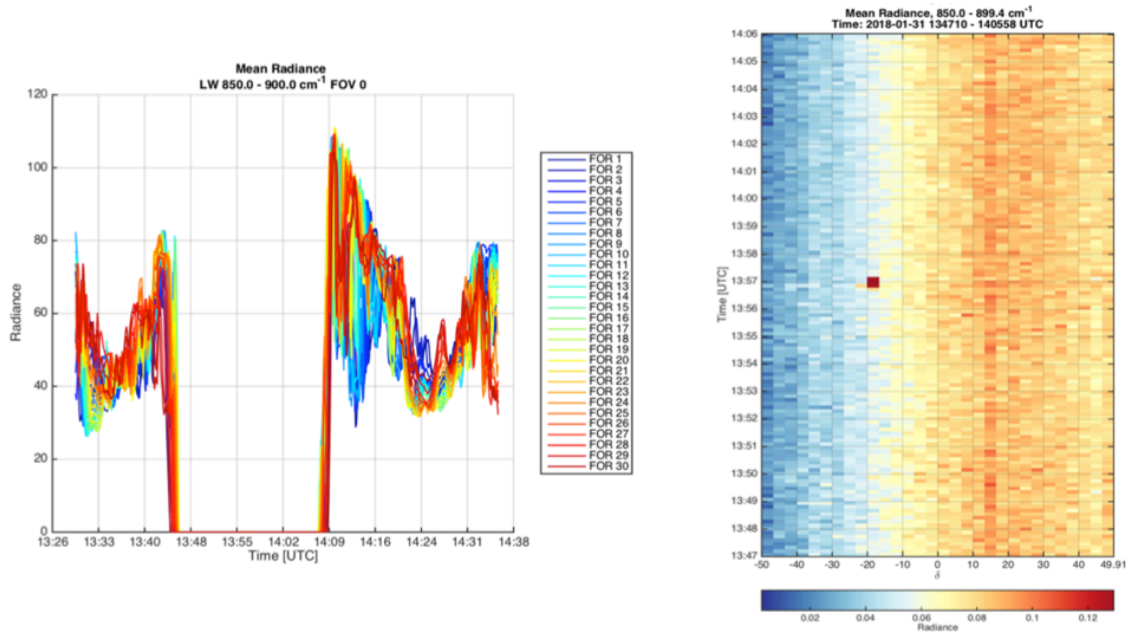

Figure 62. JPSS-1 CrIS radiance data collected during the 31 January 2018 pitch maneuver. Left panel: time series of the LW window radiance for different scan view angles (FORs). Right panel: LW window radiances as a function of time and FOR (scan angle) when viewing deep space.

### Publications and Conference Reports

**JPSS Annual Science Team Meeting**, College Park, MD, August 2017, “Progress on CrIS Calibration and Recommendation for CrIS-NG”, (Dave Tobin, Hank Revercomb, Joe Taylor, Bob Knuteson, Dan DeSlover, Lori Borg, Graeme Martin).

**NASA Sounder Science Team Meeting**, Greenbelt, MD, 23-26 October 2017, "The Cross-track Infrared Sounder (CrIS): Its high accuracy and special properties for establishing a climate record," emphasizing CrIS accuracy and the instrument independence of its calibrated radiances compared to the AIRS grating spectrometer.

([Hank Revercomb](#), Dave Tobin, Bob Knuteson, Joe Taylor, Fred Best)

**International Strategic Consultative Committee (ISCC-4)**, Hangzhou, China, 4 -11 Nov 2017, “WS 4: The Cross-track Infrared Sounder: FTS offers high accuracy and special properties for NWP & climate trending,” with emphasis on making the HIRAS polar sounder from China as accurate as possible for its role in providing the early morning orbit for the international constellation of operational instruments starting with FY-3E in 2019. ([Hank Revercomb](#))

**CLARREO Science Definition Team Meeting**, NASA LARC NIA, 13-15 November 2017, “Techniques for Removing Instrument-dependent Spectral Features from FTS Spectra” that includes our new, highly accurate corrections for Self Apodization and responsivity dependence of calibrated radiances. ([Hank Revercomb](#), Dave Tobin, Jon Gero, Bob knuteson, Joe Taylor)

**International TOVS Study Conference (ITSC-21)**, Darmstadt, Germany, 27 Nov-7 Dec 2017, “Correction to Remove the Residual Responsivity Dependence of Spectral Instrument-Line-Shapes for Fourier Transform Spectrometers,” describing the basis for our new approach that could be used to remove responsivity dependence instead of including the responsivity in the forward model calculation.

([Hank Revercomb](#), Dave Tobin, Joe Taylor, Bob Knuteson, Jon Gero)



AGU, New Orleans, 10-15 December 2017, “Progress Toward Achieving an IR Radiance Record for Decadal Climate Trending: Fundamental Questions, Challenges, and Assessments,” that discusses the growing long term climate trending capabilities offered by combining the operation suite of FTS instrument data with that from a CLARREO-type IR standard verified on-orbit, with relevant demonstrations using CrIS data.

([Hank Revercomb](#), Bob Knuteson, Dave Tobin, Fred Best, Joe Taylor, Graeme Martin, P. Jonathan Gero, Douglas Adler, Claire Pettersen, Mark Mulligan, Don Thielman).

**GSICS Annual Meeting**, Shanghai, China, 19-23 March 2018, “Calibration status of NOAA20 CrIS and intercalibration” (Dave Tobin, Hank Revercomb, Bob Knuteson, Joe Taylor, Michelle Feltz, Graeme Martin, Dan Deslover, Lori Borg, Greg Quinn, and the JPSS Team).

## **16.2 VIIRS SDR Calibration/Validation**

**CIMSS Task Leader: Chris Moeller**

**CIMSS Support Scientist: Jun Li**

**NOAA Collaborator: Changyong Cao**

**Budget: \$150,000**

### **NOAA Long Term Goals:**

- Climate Adaptation and Mitigation
- Weather-Ready Nation

### **NOAA Strategic Goals:**

- Serve society’s needs for weather and water
- Understand climate variability and change to enhance society’s ability to plan and respond
- Support the nation’s commerce with information for safe, efficient and environmentally sound transportation
- Provide critical support for the NOAA mission

### **CIMSS Research Themes:**

- Satellite Meteorology Research and Applications
- Satellite Sensors and Techniques

## **PART 1**

### **Objective**

Establish and maintain instrument performance for all VIIRS sensors, utilizing pre-launch test characterization with on-orbit evaluation to optimize accuracy and precision of the SDR product.

### **Project Overview**

This task includes the following subtasks:

#### ***SNPP and NOAA-20 VIIRS On-Orbit SDR Performance Evaluation***

This subtask supports the ongoing application of VIIRS Cal/Val task tools at UW for SDR performance monitoring and review, including VIIRS and CrIS matchups to identify VIIRS SDR bias trends and dependence on scene temperature and scan angle. This subtask contributes to





investigations of known and revealed on-orbit performance issues and adjustments to the SDR calibration algorithm.

### ***JPSS-2 VIIRS Pre-launch Performance Characterization***

Participation in the JPSS-2 VIIRS pre-launch test program is separately funded under the Flight Project; however pre-launch test data analysis supporting the launch readiness and the post-launch JPSS-2 SDR product performance is partially supported under this subtask

### ***Support STAR and SDR Team Meetings and Activities***

UW is continuing participation on the VIIRS SDR Team, providing analyses on VIIRS SDR performance and participating in the review of all VIIRS performance issues.

## **Milestones with Summary of Accomplishments and Findings**

### ***VIIRS On-Orbit SDR Performance Evaluation***

- Daily SNPP VIIRS-CrIS radiance comparisons over the SNPP mission lifetime (Figure 63, upper left panel) continue to reveal excellent calibration performance for bands M13, M15, M16 and I5 with globally averaged differences within about +/- 0.1 K for typical scenes. Radiometric trends appear to remain very small, < 5 mK/year in all bands. A seasonal cycle appears in M13 that may be due to scene temperature dependence, increasing the bias in the Austral winter season due to cold scenes over Antarctica. Existing scene temperature dependence remains within specification at all scene temperatures for these bands as demonstrated by the case study (Figure 63, upper right panel) which is typical of all dates. The M13 bias in cold scenes is evident, as is a smaller cold scene bias in M15. For NOAA-20, the very short on-orbit data record shows no meaningful trends in M13, M15, M16, or I5 (Figure 63, lower left panel); however, a clear behavior of scene temperature dependence in the biases departs from that of SNPP, particularly for band M15 (Figure 63, lower right panel). This raises a concern that the NOAA-20 SST product and possibly other products that use M15 and M16 together may be biased as a function of scene temperature.
- The HAM RVS (scan angle dependence) shows good performance as bands M13, M15, M16, and I5 all exhibit small (< 0.1 K) scan angle dependence for SNPP with a minor scene temperature dependence superimposed. NOAA-20 VIIRS however shows a stronger scene temperature dependence within the scan angle dependence, especially for band M15 (Figure 64). This early performance is related to scene temperature dependence seen in Figure 63 and is the subject of further investigation.
- Both SNPP and NOAA-20 VIIRS band M6 radiances show evidence of “fold overs” in SDR (calibrated radiance decreases as signal on detector increases). For SNPP, band M6 radiances are also exceeding the maximum allowed radiance of 60 W/m<sup>2</sup> sr um causing the earth scene radiance to be designated as “saturated” in the SDR product and resulting in a loss of earth scene information in band M6. An adjustment upward of the saturated radiance threshold would restore the information content of the earth scene radiances to the SDR product. For NOAA-20, the fold-overs are now and will continue to occur at radiances below the specified L<sub>max</sub> radiance of M6. Some EDR products that rely on M6 for an atmospheric correction may be adversely affected by this.
- NOAA-20 VIIRS-CrIS comparisons have been reviewed over the duration of a VIIRS warmup-cooldown (WUCD) exercise that took place on January 22-24, 2018. The NOAA-20 VIIRS shows a response to the changing OBC temperature that is about half (NOAA-20 M15 about 50 mK; SNPP M15 about 100 mK) of that observed during SNPP



VIIRS WUCD exercises, suggesting that the NOAA-20 instrument thermal model may be a better representation of VIIRS thermal characteristics than that for SNPP.

- Early in the NOAA-20 mission, changes in F factors for LWIR bands M15, M16, and I5 were noted. The spectral profile of those changes suggested that an ice layer might be building up on some optical component (e.g. LWIR dewar window) of VIIRS and impacting the relative spectral response (RSR) shape of the bands, especially M15 since it is located on a slope of the theoretical ice absorption spectral profile. An investigation was undertaken to explore the spectral and radiometric impact of unchecked ice buildup over time. The results of this effort showed a 10 – 20 mK impact on the M15 calibration that could increase error in the SST product. A mid mission outgas exercise was undertaken by project and proved successful in restoring the LWIR F factors to baseline.

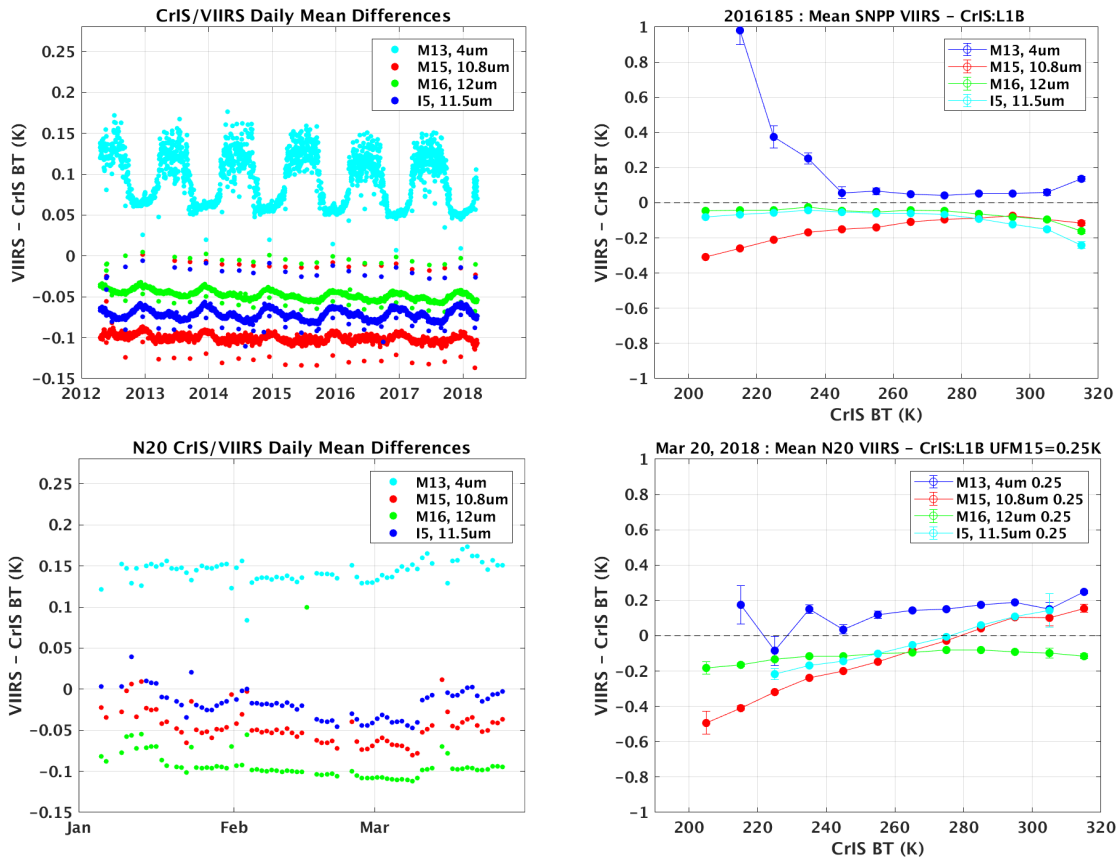

Figure 63. Time series of VIIRS-CrIS comparisons for SNPP and NOAA-20 (upper and lower left, resp.). VIIRS-CrIS comparisons as a function of scene temperature (upper and lower right).

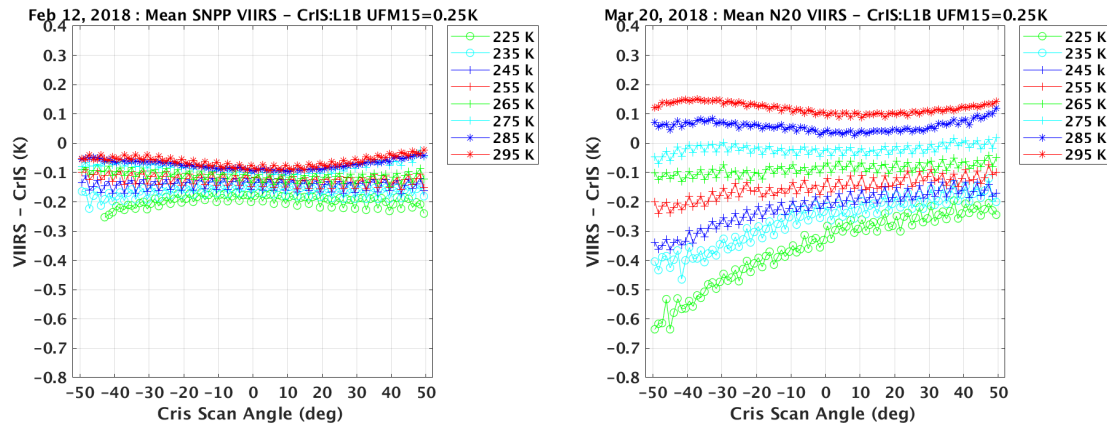

Figure 64. VIIRS-CrIS comparisons as a combined function of scan angle and scene temperature for SNPP (left) and NOAA-20 (right).

### JPSS-2 VIIRS Pre-launch Performance Considerations

The JPSS-2 VIIRS has completed its sensor level prelaunch test program (UW participation supported under separate funding). The spectral position of band M9, the cirrus detection band, has shifted to longer wavelengths under the newly procured filters for JPSS-2 VIIRS spectral bands. This places the JPSS-2 M9 band into a region of slightly weaker water vapor absorption, which allows more reflected light from the earth's surface to reach the JPSS-2 M9 detectors than M9 on SNPP and NOAA-20. A sensitivity study was undertaken to explore the possible change to JPSS-2 M9 ability to detect cirrus. The study used currently available M9 cirrus detection performance from SNPP VIIRS and Aqua MODIS coupled with 2-way model transmittance calculations using the spectral characterization of the cirrus detection band on all these instruments. The findings are that false detection of cirrus cloud can expect to increase for JPSS-2 compared to SNPP (and NOAA-20) for dry atmospheres, e.g. Central Canada in winter season. While difficult to quantify the impact, the data suggests that the JPSS-2 performance will be somewhere about midway between the ~10% false rate of SNPP and the 50% false rate of Aqua MODIS for those dry atmospheres. This may motivate adjustments to M9 test design and thresholds used for cloud detection.

## PART 2

### Project Overview

The CrIS and VIIRS instruments fly together on the SNPP and NOAA-20 platform enabling a sample of collocation matchups that cover all times, all weather, and over all surface types. This provides an opportunity for comprehensive inter-comparisons. Previous work has pointed out the advantages of using CrIS to assess VIIRS calibration [Moeller et al., 2013; Wang et al., 2016]. However, an understanding of how CrIS sub-pixel cloud, surface type and local zenith angle impact the differences between CrIS and VIIRS is needed. In addition, during the unsteady state of quarterly warm up/cool down (WUCD) exercises, the performances of thermal emissive bands (TEBs) [Madhavan et al., 2016; Li et al., 2016; Wang et al., 2016] and effects of correction algorithms [Choi et al., 2016; Cao et al., 2017] need further assessments. Methodologies and tools are needed to process and stratify CrIS and VIIRS matchups to understand the impact of cloudiness and surface types on the VIIRS/CrIS differences.

IDPS VIIRS SDR processing for RSB relies on a solar diffuser based calibration; any unaccounted degradation in the solar diffuser degrades the SDR product accuracy. Unaccounted



degradation has been suggested by Lunar observations, especially for bands M1-M4 which impact the ocean color, cloud and aerosol products. To address these issues, there is need to improve the RSB calibration stability using complimentary approaches: Lunar calibration and deep convective clouds (DCC). A preliminary study using DCC has been done by Wang and Cao (2016). However, it was based on monthly/semi-monthly statistics. Weekly statistics are desirable, using better screening with collocated hyperspectral CrIS to support higher quality DCC calibration to enable 0.1% RSB stability.

## **Milestones with Summary of Accomplishments and Findings**

### ***Inter-comparison between VIIRS and CrIS by taking into account the CrIS sub-pixel cloudiness and viewing geometry***

The CrIS onboard the Suomi NPP (and the upcoming JPSS series) has high radiometric accuracy, which can be used to validate the radiance observations from VIIRS onboard the same platform. Collocated CrIS and VIIRS sensor data records (SDRs) along with the VIIRS cloud mask product from 19 to 21 September 2016 (a quarterly warm up/cool down (WUCD) calibration period) are used for the inter-comparisons. This work addresses the question of how CrIS sub-pixel cloud presence and local zenith angle impact the differences between CrIS and VIIRS. The brightness temperature (BT) biases and standard deviations (STD) of VIIRS bands (M13, M15, M16 and I5) with respect to those from the CrIS (when the radiances are convolved over the VIIRS spectral response functions (SRFs)) are used for analysis. Results show a good agreement between CrIS and VIIRS when sub-pixel cloudiness and zenith angle are accounted for; both have an impact on STD as well as on bias. Time series show the impact of WUCD and the effects of a correction algorithm applied to M15 and M16 reprocessed data. The analysis is useful for VIIRS calibration corrections and environmental data record (EDR) product improvements (e.g., sea surface temperature, land surface temperature and land surface emissivity). The methods and tools can be applied to monitor and validate any imager with an advanced infrared (IR) sounder onboard the same platform, such as CrIS and VIIRS (SNPP, JPSS series), and IASI and AVHRR (MetOp series). A manuscript (Gong et al. 2018) on the VIIRS/CrIS inter-comparisons has been submitted to Journal of Geophysical Research – Atmospheres for publishing.

In addition, CIMSS scientists collaborated with STAR scientists (Changyong Cao and Wenhui Wang) on verifying the impact from VIIRS SDR bias correction techniques (Cao et al. 2017).

### ***CrIS-based DCC detection for near real-time VIIRS RSB monitoring developed and is online***

As uniform and stable objects, the deep convective clouds (DCCs) can be used to monitor the radiometric stability of VIIRS reflective solar bands (RSBs) and Day-Night-Band (DNB). Usually DCC subjects are identified by VIIRS 11  $\mu\text{m}$  band brightness temperature (BT11). CrIS has a better performance of DCC identification than VIIRS with brightness temperature difference (BTD) between its stronger and weaker water vapor absorption channels. By combining the collocated CrIS BTD and measurement noise ratio (BNR), a new method for DCC identification is adapted (Ai et al. 2017). The methodologies and technical approaches on monitoring VIIRS RSB calibrations using DCC detected by collocated CrIS measurements are developed. The reflectance of VIIRS RSB (M1-M11 and I1-I3) of DJF and JJA seasons of 2017 are used for verification. The reflectance PDF, Mean and Mode of DJF and JJA seasons as well as time series of reflectance means and modes are calculated for analyzing. Results show the DCCs identified by BTD/BNR method not only have higher Means and Modes for each season, but also are more robust in time series than the DCCs identified by legacy BT11 method for visible and near infrared (VIS/NIR) bands; while BT11 method have better performances than



BTD/BNR method in short-wavelength infrared (SWIR) spectrums. Figure 65 shows the (a) daily and (b) weekly time series of M07 reflectance modes (dashed lines) and means (solid lines) of DCCs selected by BNR > 1 (red) and M15 BT (blue) of JJA season of 2017. The reflectance Mean and Mode of JJA's, as well as the standard deviation (STD, unit: %) and the variation range (VAR, unit: %) of time series of DCC reflectance means and modes are calculated and shown in texts above each panel.

This combined method can be applied to other imagers with collocated advanced infrared sounders to monitor the radiometric stability of RSBs, such as VIIRS with CrIS onboard the JPSS satellites, AVHRR with IASI onboard the MetOp series. The methodology has been applied to SNPP for near real-time VIIRS RSB monitoring:

<http://www.ssec.wisc.edu/dcc/>

This website shows the most recent one year of the time series of daily and weekly reflectance, along with the mean and mode, their standard deviations (STD) and ranges (maximum-minimum). For the monthly time series of the whole SNPP mission lifetime, it also refers to the STAR VIIRS RSBs monitoring using DCC (monthly time series).

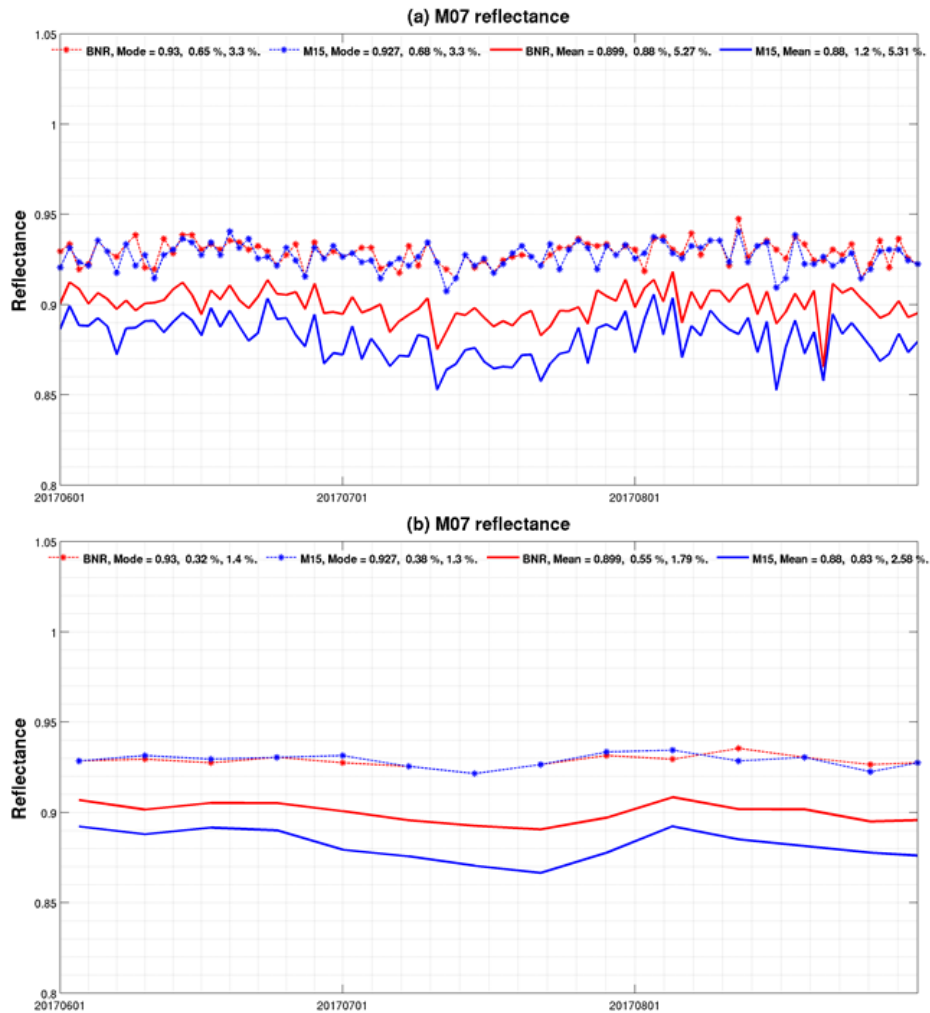

Figure 65. The (a) daily and (b) weekly time series of M07 reflectance modes (dashed lines) and means (solid lines) of DCCs selected by BNR > 1 (red) and M15 BT (blue) of JJA season of 2017. The reflectance Mean and Mode of JJA's, as well as the standard deviation (STD, unit: %) and the variation range (VAR, unit: %) of time series of DCC reflectance means and modes are calculated and shown in texts above each panel.



## Publications and Conference Reports

Ai, Y., W. Shi, Jun Li, T. Schmit, C. Cao, and W. Li, 2017: Deep convective cloud characterizations from both broadband and hyperspectral infrared sounder measurements, *Journal of Geophysical Research - Atmospheres*. 10.1002/2016JD025408.

Gong, Xinya, Zhenglong Li, Jun Li, Chris Moeller, Changyong Cao, Wenhui Wang, and W. Paul Menzel, 2018: Inter-comparison between VIIRS and CrIS by taking into account the CrIS sub-pixel cloudiness and viewing geometry, *Journal of Geophysical Research – Atmospheres* (conditionally accepted).

Xinya Gong, Zhenglong Li, Jun Li, Chris Moeller, Changyong Cao, and Wenhui Wang, 2018: Monitoring the VIIRS SDR reflective solar band calibrations using DCC with collocated CrIS and VIIRS measurements, *Journal of Geophysical Research – Atmospheres* (to be submitted).

Wang, Wenhui, Changyong Cao, Alex Ignatov, Zhenglong Li, Likun Wang, Bin Zhang, Slawomir Blonski, and Jun Li, 2017: Operational correction and validation of the VIIRS TEB longwave infrared band calibration bias during blackbody temperature changes, *SPIE Proceedings Volume 10402, Earth Observing Systems XXII*; 104021P (2017); doi: 10.1117/12.2272377.

## References

Ai, Y., W. Shi, Jun Li, T. Schmit, C. Cao, and W. Li, 2017: Deep convective cloud characterizations from both broadband and hyperspectral infrared sounder measurements, *Journal of Geophysical Research - Atmospheres*. 10.1002/2016JD025408.

Cao, Changyong, Wenhui Wang, Slawomir Blonski, and Bin Zhang, 2017: Radiometric traceability diagnosis and bias correction for the Suomi NPP VIIRS long-wave infrared channels during blackbody unsteady states, *Journal of Geophysical Research – Atmospheres*, 10.1002/2017JD026590.

Choi, T. J., C. Cao, and F. Weng (2016), S-NPP VIIRS thermal emissive band gain correction during the blackbody warm-up-cool-down cycle, paper presented at SPIE Optical Engineering+ Applications, International Society for Optics and Photonics.

Li, Y., A. Wu, and X. Xiong (2016), Inter-comparison of S-NPP VIIRS and Aqua MODIS thermal emissive bands using hyperspectral infrared sounder measurements as a transfer reference, *Remote Sensing*, 8(1), 72, doi:10.3390/rs8010072.

Madhavan, S., J. Brinkmann, B. N. Wenny, A. Wu, and X. Xiong (2016), Evaluation of VIIRS and MODIS Thermal Emissive Band Calibration Stability Using Ground Target, *Remote Sensing*, 8(2), 158, doi:10.3390/rs8020158.

Wang, Z., X. Xiong, and Y. Li (2016), Update of S-NPP VIIRS thermal emissive bands radiometric calibration stability monitoring using the moon, paper presented at SPIE Remote Sensing, International Society for Optics and Photonics.



## **17. SSEC/CIMSS Research Tasks in Support of SuomiNPP and the Joint Polar Satellite System (JPSS) Sounding and Cyrosphere Environmental Data Records (EDR)**

### **17.1 CrIMSS EDR Cal/Val: ARM Site Support 2017**

**CIMSS Task Leader: Lori Borg**

**CIMSS Support Scientists: David Tobin, Michelle Feltz, Robert Knuteson**

**NOAA Collaborators: Tony Reale, Nicholas Nalli, Lihang Zhou**

**Budget: \$53,000**

#### **NOAA Long Term Goals:**

- Climate Adaptation and Mitigation
- Weather-Ready Nation

#### **NOAA Strategic Goals:**

- Serve society's needs for weather and water
- Understand climate variability and change to enhance society's ability to plan and respond
- Provide critical support for the NOAA mission

#### **CIMSS Research Themes:**

- Satellite Meteorology Research and Applications
- Satellite Sensors and Techniques

#### **Objective**

Coordination of radiosonde launches coincident with overpasses of the SNPP and NOAA20 satellites for the critical validation of SNPP CrIS/ATMS atmospheric temperature and water vapor retrieved profiles.

#### **Project Overview**

Over the last year, this effort involved the continuing coordination of sonde launches at the Eastern North Atlantic (ENA), North Slope Alaska (NSA), and Southern Great Plains (SGP) ARM sites coincident with overpasses of the SNPP and NOAA20 satellites. Targeting of SNPP overpasses, which began in July 2012, ended in January 2018 and targeting of NOAA20 overpasses began in February 2018. This collaborative effort with ARM to target NOAA20 overpasses is anticipated to be repeated throughout the NOAA20 mission life and will provide data critical for the validation of the NOAA20 CrIS/ATMS atmospheric temperature and water vapor retrieved profiles.

#### **Milestones with Summary of Accomplishments and Findings**

In January 2018, radiosonde launches for SNPP validation were concluded. These efforts, which began in July 2012, targeted over 1200 SNPP overpasses at four ARM sites including; ENA, NSA, SGP, and Tropical West Pacific (TWP) at Manus. More detailed information regarding the SNPP radiosonde efforts can be found in Table 8. These radiosondes were used in the recent SNPP NOAA-Unique Combined Atmospheric Processing System (NUCAPS) validation papers by Nalli et al. 2018 and Feltz et al. 2018. In February 2018, radiosonde launches began targeting NOAA20 overpasses at the ENA, NSA, and SGP sites. While, only a handful of NOAA20 radiosonde launches have been performed to date, the current phase of launches (Phase-6) will include an additional 61/111/120 JPSS funded sondes being launched at ENA/NSA/SGP respectively by the end of September 2018. These launches will also be coordinated with the



Radiosonde Intercomparison and VALidation (RIVAL) field campaign at ARM, allowing for weekly dual launches (RS92 & RS41 sondes on the same balloon) targeting NOAA20. More detailed information regarding the NOAA20 radiosonde efforts can be found in Table 9.

**Table 8. SNPP Sonde Launch Efforts: July 2012 – January 2018. Single sonde launches occur 15-minutes prior to overpass and twin launches occur 45- and 5-min prior to overpass.**

SNPP Radiosonde Launches						
Phase	ARM Site	Start Date	Stop Date	nOverPasses Targeted	nSingle Sondes	nTwin Sondes
1	NSA	Jul12	Dec12	90	--	90
	SGP		Jan13	89	--	89
	TWP		Jun13	94	94	--
2	NSA	Jun13	Sep14	124	68	56
	SGP			129	31	98
	TWP		May14	79	79	--
3	ENA	Feb15 - Sep15		38	38	--
	NSA			46	23	23
	SGP			53	23	30
4	ENA	Oct15 - Sep16		80	80	--
	NSA			88	55	33
	SGP			86	16	70
5	ENA	Oct16 - Sep17		78	78	--
	NSA			68	28	40
	SGP			85	66	19
6	ENA	Oct17 - Jan18		8	8	--
	NSA			9	9	--
	SGP			8	7	1

**Table 9. NOAA20 Sonde Launch Efforts: Feb 2018 – present. Single sonde launches occur 15-minutes prior to overpass, twin launches occur 45- and 5-min prior to overpass, and RIVAL launches include both a RS41 & RS92 radiosonde on the same balloon.**

NOAA20 Radiosonde Launches						
Phase	Site	Start	Stop	nRIVAL	nSingle	nTwin
6	ENA	Feb18	ongoing	--	2	--
	NSA			--	--	2
	SGP			1	--	1

### Publications and Conference Reports

Borg, Lori, Feltz, M., Knuteson, R., Tobin, D., Reale, T., Liu, Q., Holdridge, D., and Mather, J. *JPSS Radiosonde Program: Validation of NUCAPS at ARM Sites*. Oral Presentation. STAR JPSS Annual Science Team Meeting, 14-18 August 2017, Greenbelt, MD.

Nicholas R. Nalli, Gambacorta, A., Liu, Q., Barnet, C., Tan, C., Iturbide-Sanchez, Reale, T., Sun, B., Wilson, M., Borg, L., and Morris, V., Validation of Atmospheric Profile Retrievals From the SNPP NOAA-Unique Combined Atmospheric Processing System. Part 1: Temperature and Moisture. *IEEE Transactions on Geoscience and Remote Sensing*, Volume: 56, Issue: 1, Jan 2018. DOI: 10.1109/TGRS.2017.2744558.

Feltz, M. L.; Borg, L.; Knuteson, R. O.; Tobin, D.; Revercomb, H. and Gambacorta, A.. Assessment of NOAA NUCAPS upper air temperature profiles using COSMIC GPS radio





occultation and ARM radiosondes. *Journal of Geophysical Research-Atmospheres*, Volume: 122, Issue: 17, Sep 2017, pp.9130-9153.

## **17.2 Science and Management Support for NPP VIIRS Snow and Ice EDRs**

**CIMSS Task Leader: Yinghui Liu**

**CIMSS Support Scientists: Xuanji Wang, Richard Dworak, Aaron Letterly**

**NOAA Collaborator: Jeffrey Key**

**Budget: \$143,000**

### **NOAA Long Term Goals:**

- Climate Adaptation and Mitigation
- Weather-Ready Nation
- Healthy Oceans

### **NOAA Strategic Goals:**

- Serve society's needs for weather and water
- Understand climate variability and change to enhance society's ability to plan and respond
- Provide critical support for the NOAA mission

### **CIMSS Research Themes:**

- Satellite Meteorology Research and Applications

### **Objective**

To provide science and management support for NPP VIIRS snow and ice EDRs.

### **Project Overview**

The Visible Infrared Imaging Radiometer Suite (VIIRS) provides the majority of the Environmental Data Records (EDR) on the Suomi National Polar-orbiting Partnership (NPP; formerly the NPOESS Preparatory Project) satellite. Cryosphere (snow and ice) products are fundamental to weather prediction, hazard detection, transportation, recreation, and climate monitoring, and are therefore an important part of the suite of VIIRS EDRs.

NESDIS/STAR is taking the managerial and technical leadership of NPP and Joint Polar Satellite System (JPSS) cryosphere product development and evaluation activities. The JPSS Cryosphere Team is producing snow and ice Environmental Data Records (EDRs) from visible, infrared, and microwave data. For the purposes of this effort, however, only those EDRs produced from VIIRS are considered. The VIIRS snow and ice EDRs are sea ice characterization, sea ice concentration, and snow cover/depth. Sea ice characterization includes sea ice thickness and age, and an sea ice surface temperature intermediate product (IP).

The Cryosphere Team is a unified combination of Subject Matter Experts (SMEs) from academia and government. Scientists from the Cooperative Institute for Meteorological Satellite Studies (CIMSS) at the University of Wisconsin-Madison are an integral part of the team. Research at CIMSS focuses on the sea ice EDRs, in collaboration with colleagues at the Cooperative Institute for Research in the Environmental Sciences (CIRES) at the University of Colorado-Boulder. Snow cover/depth research is being funded, conducted, and reported separately at the Cooperative Remote Sensing Science and Technology Center (CREST)/City College of New York (CCNY).



## Milestones with Summary of Accomplishments and Findings

The CIMSS cryosphere team continues to obtain VIIRS SDRs, IPs, and EDRs from the GRAVITE and CLASS systems, checking the quality of these SDRs and EDRs, and performing comparisons with all other available datasets, visually and quantitatively. The SDRs include VIIRS moderate resolution band SDRs, VIIRS image band SDRs, and corresponding terrain-corrected geolocation SDRs. The IPs include VIIRS ice concentration IP (SIC), VIIRS ice reflectance and temperature IP, VIIRS ice quality flag IP, VIIRS ice weights IP, and VIIRS cloud mask IP. The EDRs include VIIRS ice surface temperature EDR, VIIRS sea ice characterization EDR, VIIRS cloud cover and layers EDR.

### Ice Surface Temperature

The VIIRS ice surface temperature (IST) product plays important role in the retrievals of sea ice concentration and thickness in addition to its own importance in the weather and climate analyses. The IST product provides surface temperatures retrieved at VIIRS moderate resolution (750m), for Arctic and Antarctic sea ice, both day and night. IST is the radiating, or "skin", temperature at the ice surface. It includes the aggregate temperature of objects comprising the ice surface, including snow and melt water on the ice. The baseline split window algorithm statistical regression method is based on the IST algorithm of Key and Haeffliger (1992), and the threshold measurement uncertainty is about 1 K over the measurement range of 213 - 275 K.

The VIIRS "Enterprise" IST product has been validated against NASA IceBridge KT-19 IR surface temperature, MODIS ice surface temperature, Arctic drifting buoy air temperature, and NCEP/NCAR reanalysis. Figure 66 and Figure 67 show the VIIRS IST validation and comparison results with IceBridge KT-19 and MODIS.

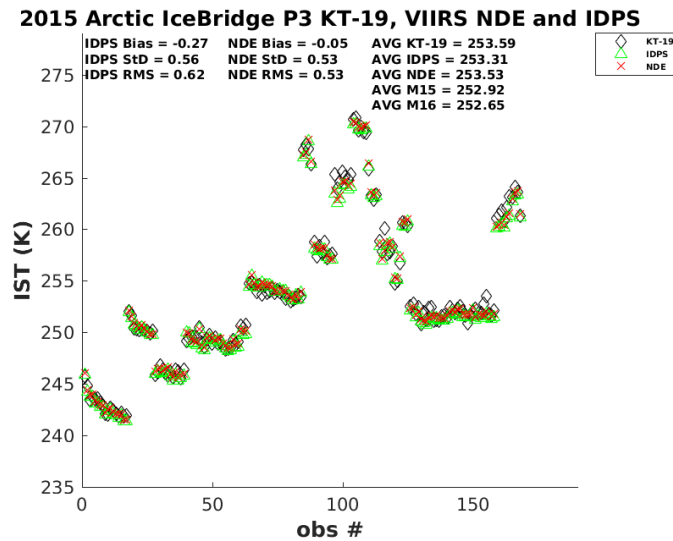
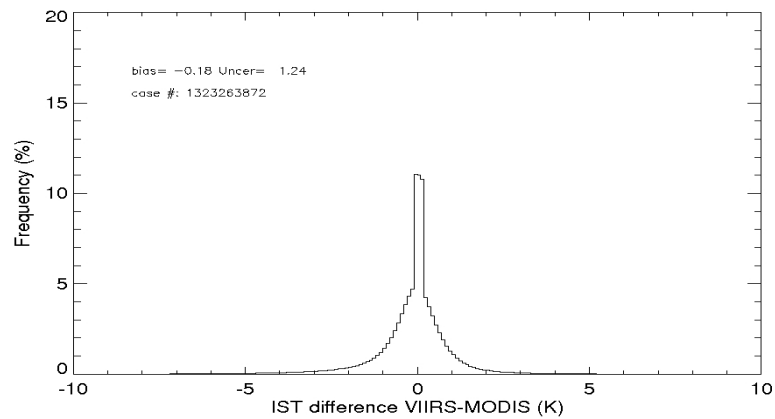
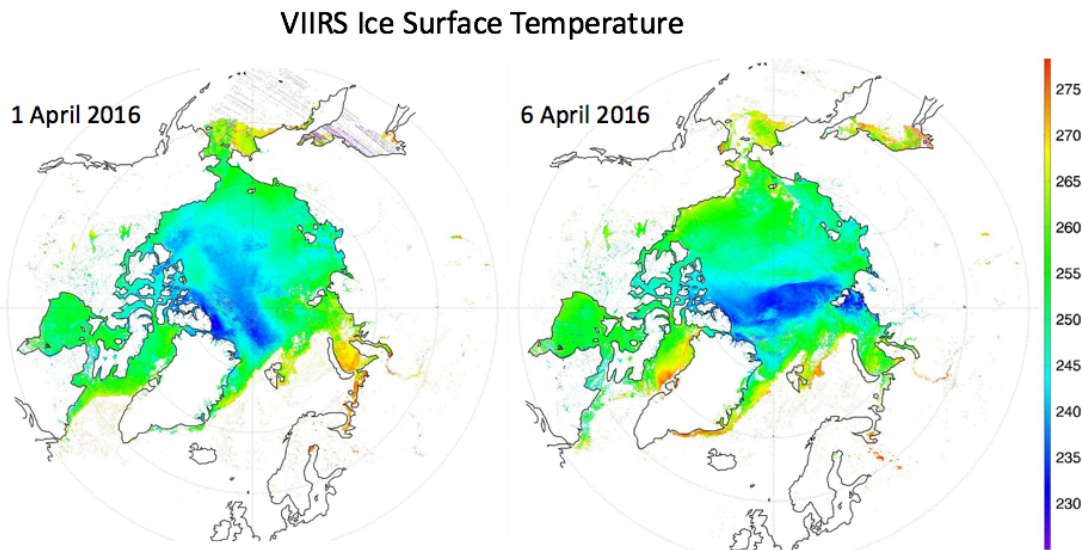

Figure 66. VIIRS IST (red), IDPS IST (green), and IceBridge P3 KT-19 IST (black) for all coincident IceBridge flights with cloud-free observations over the Arctic in 2015.



**Figure 67. Differences between NPP VIIRS and MODIS (Aqua and Terra) IST in the Arctic for all cases from August 2012 to July 2015.**

One application example of the VIIRS IST product is a warming event happened during the first week of April 2016 that was observed over Baffin Bay and verified by The NCEP Climate Forecast System Version 2 (CFSv2) Reanalysis. By 7 April 2016 the mean surface temperatures rose by 10 to 20° C with surface temperature anomalies of up to 20° C off the west central coast of Greenland. Figure 68 shows the abrupt warming in Baffin Bay revealed by VIIRS IST in the first week of April 2016.

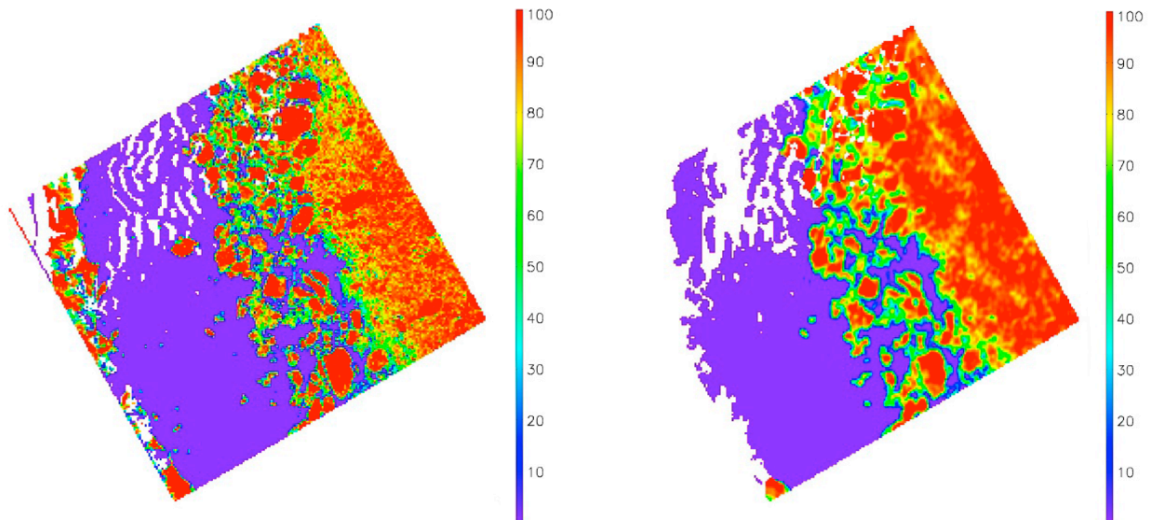

**Figure 68. Daily composites of S-NPP VIIRS Ice Surface Temperature using the Enterprise algorithm. Left: 1 April 2016; right: 6 April 2016. IST was in the range of 245-265 K on 1 April, warming to 255-275 K by 6 April, probably caused by a strong ridge of high pressure developed over Greenland, allowing warm air from the south to be advected over the Baffin Bay region.**

### **Sea Ice Concentration**

VIIRS ice concentration is derived using the NOAA “Enterprise” algorithms. The VIIRS ice concentration algorithm classifies a pixel as ice or no-ice using a threshold method, and calculates the pixel ice concentration using a tie point approach, and generates ice concentration at VIIRS M-band resolution at 750 m at both daytime and nighttime.

The Enterprise ice concentration (IC) continues to be validated using ice concentration derived from high-resolution imagery of Landsat 8, and from the Special Sensor Microwave Imager Sounder (SSMIS). Validation with Landsat is restricted to the months of February through October. A daily mean sea ice concentration product has been also obtained from the Special Sensor Microwave Imager/Sounder (SSMIS) onboard the Defense Meteorological Satellite Program (DMSP) F17 satellite. Lastly, the NASA Team 2 sea ice concentration algorithm was applied to AMSR2 cases in winter, spring, and summer for an additional comparison to VIIRS ice concentration. Figure 69 shows the comparison between VIIRS IC and Landsat IC.



**Figure 69.** (left) Ice concentration (IC) derived from the Landsat image (30 m resolution); and (right) the calculated IC using the Suomi NPP VIIRS. White areas denote pixels flagged out as either land or cloud.

VIIRS Enterprise ice concentration (IC), along with ice surface temperature and ice thickness products, has been generated and monitored routinely, and figures have been archived and shown on CIMSS website at <http://stratus.ssec.wisc.edu/ice-products/anibrowser/index.php>. In addition, the ice concentration product is also archived by Naval Research Laboratory for applications in model simulation and Walt Meier of GSFC for comparison with microwave products.

### **Sea Ice Age and Thickness**

The VIIRS Enterprise sea ice thickness is derived with the One-dimensional Thermodynamic Ice Model (OTIM) that is based on the surface energy budget at thermo-equilibrium state initially, and gradually evolved into a physical-statistical hybrid model for both GOES-R ABI and JPSS VIIRS data. The ice thickness algorithm (OTIM) has been improved and updated several times. The new version of OTIM has been coded and tested with NPP VIIRS data. This version has many improvements in many old and new algorithms. The major improvements include: 1. Residual heat flux is now estimated by a regression algorithm, other than the old lookup tables that were removed from new version; 2. Ice thermodynamic processes (growing and melting processes) are considered and parameterized in the new version; 3. Ice physical dynamic processes (rafting, hommocking, ridging, and etc. processes) are also considered and parameterized in the new version for the Arctic Ocean; 4. Snow depth on ice is now estimated by a snow depth climatological data in terms of date and location if snow depth data are unknown.

Due to the significant improvements in the new FORTRAN 95 version of the OTIM for use with JPSS VIIRS data, many of the old subroutines were revised and optimized, and 11 new



subroutines were added to the new version of the OTIM. Table 10 lists the old and new versions of the OTIM for their file names, subroutine names, and functions.

**Table 10. FORTRAN 95 Subroutines in OTIM Package.**

File Name	Subroutine/Function Name	Function	Old Version	New Version
AITA_PROGRAM_IceMain.f95	IceMain	Main subroutine (input/output)	✓	✓
AITA_SUBROUTIN_IceThickness.f95	IceThickness	Ice thickness retrieval	✓	✓
AITA_SUBROUTIN_IceAge.f95	IceAge	Ice age retrieval	✓	✓
AITA_SUBROUTIN_VarInitialization.f95	VarInitialization	Variables initialization	✓	✓
AITA_SUBROUTIN_QCPQIInformation.f95	QCPQIInformation	QC/PQI information	✓	✓
AITA_SUBROUTIN_HumidityConversion.f95	HumidityConversion	Humidity unit conversion	✓	✓
AITA_SUBROUTIN_SurfDownSolar.f95	SurfDownSolar	Surface SWDRF calculation	✓	✓
AITA_SUBROUTIN_SurfDownThermal.f95	SurfDownThermal	Surface LWDRF calculation	✓	✓
AITA_SUBROUTIN_SurfUpThermal.f95	SurfUpThermal	Surface LWURF calculation	✓	✓
AITA_SUBROUTIN_SurfHeatConductive.f95	SurfHeatConductive	Surface conductive heat flux calculation	✓	✓
AITA_SUBROUTIN_SurfHeatLatent.f95	SurfHeatLatent	Surface latent heat flux calculation	✓	✓
AITA_SUBROUTIN_SurfHeatSensible.f95	SurfHeatSensible	Surface sensible heat flux calculation	✓	✓
AITA_SUBROUTIN_ResidualFlux.f95	ResidualFlux	Surface residual heat flux calculation		✓
AITA_SUBROUTIN_julday.f95	julday	Julian day number calculation		✓
AITA_SUBROUTIN_exponential_function.f95	exponential_function	Exponential function		✓
AITA_SUBROUTIN_randomu_numbers.f95	randomu_numbers	Random number generation		✓
AITA_SUBROUTIN_snow_depth_climatology.f95	snow_depth_climatology	Snow depth climatological value estimation		✓
AITA_SUBROUTIN_caldat.f95	caldat	Julian day and Calendar date conversion		✓
AITA_SUBROUTIN_adjfac4var.f95	adjfac4var	Factor adjustment function		✓
AITA_SUBROUTIN_date4latitude.f95	date4latitude	Event date occurrence estimator		✓
AITA_SUBROUTIN_rate4latitude.f95	rate4latitude	Rate adjustment upon latitude		✓
AITA_SUBROUTIN_varadj_date_icechg.f95	varadj_date_icechg	Ice thickness thermodynamic process (freezing/melting) adjustment		✓
AITA_SUBROUTIN_varadj_date_latlon.f95	varadj_date_latlon	Ice thickness physical dynamic process (rafting, ridging, et al) adjustment		✓

The Enterprise ice thickness (IC) product has been validated using ice thickness products derived from other satellites, aircraft measurements, and in-situ measurements. The recent validation and



comparison of VIIRS ice thickness with NASA IceBridge (aircraft lidar and snow radar) is shown in the Figure 70 below.

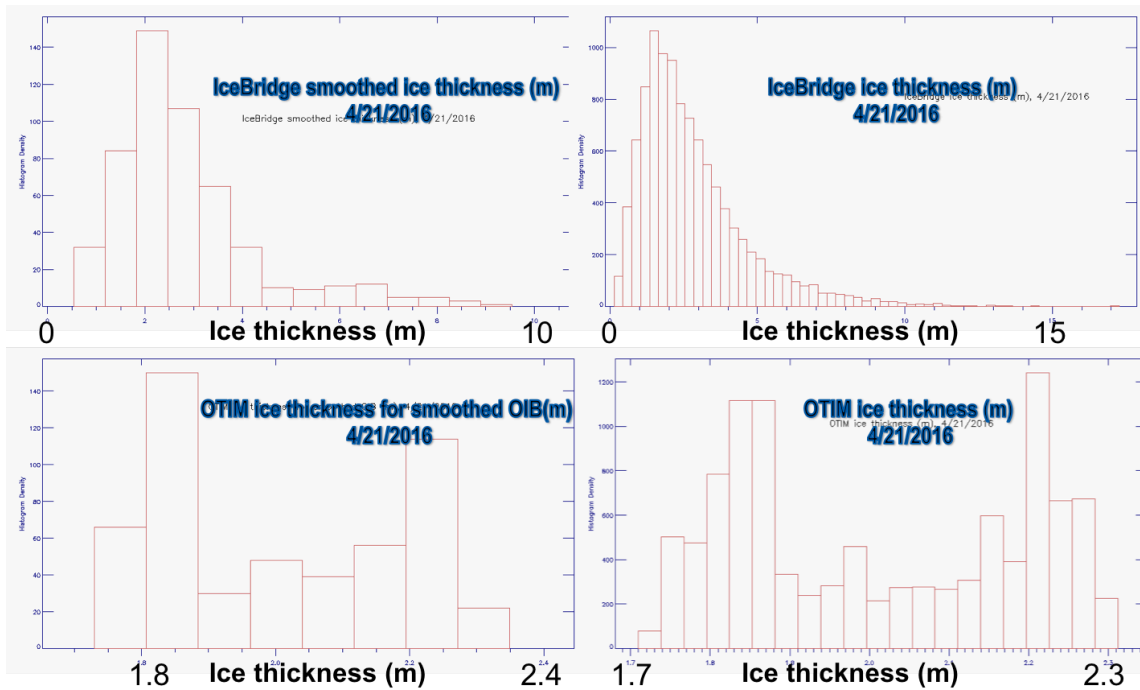

**Figure 70. Statistical results of the comparison in sea ice thickness between S-NPP (OTIM) and NASA IceBridge (aircraft lidar + snow radar) for matched locations.**

### **Publications and Conference Reports**

Xuanji Wang, Jeff Key, and Aaron Letterly, Polar Warming Revealed by Cryosphere Changes, 2017 NOAA Satellite Conference, July 17 – 20, 2017, hosted by NOAA Cooperative Science Center for Earth System Sciences and Remote Sensing Technologies (CREST), July 17-20, 2017, New York.

Xuanji Wang, Jeff Key, and Mark Tschudi, Sea ice thickness and Age (Talk), 2017 STAR JPSS Annual Science Team Meeting, 14-18 August 2017, NOAA Center for Weather and Climate Prediction Conference Center, 5830 University research court, College Park, MD 20740.

Jeff Key and Xuanji Wang, Recent Trends in Sea Ice Thickness from New Satellite Products (Talk), AMS Annual Meeting, Seattle, WA, January 2017.

Yinghui Liu, Jeff Key, Richard Dworak, Mark Tschudi, and Dan Baldwin, S-NPP Ice Concentration Status, 2017 STAR JPSS Annual Science Team Meeting, 14-18 August 2017, NOAA Center for Weather and Climate Prediction Conference Center, 5830 University research court, College Park, MD 20740.

Yinghui Liu, Jeff Key, and Richard Dworak, Blended VIIRS+Microwave Ice concentration, 2017 STAR JPSS Annual Science Team Meeting, 14-18 August 2017, NOAA Center for Weather and Climate Prediction Conference Center, 5830 University research court, College Park, MD 20740.



## References

Xuanji Wang, Jeffrey Key, Ron Kwok, Jinlun Zhang, 2016, Comparison of Sea Ice Thickness from Satellites, Aircraft, and PIOMAS Data, *Remote Sens.*, Special Issue: Sea Ice Remote Sensing and Analysis, 2016, 8(9), 713; doi:10.3390/rs8090713.

Xuanji Wang, Jeffrey Key, and Yinghui Liu, 2010, A thermodynamic model for estimating sea and lake ice thickness with optical satellite data, *J. Geophys. Res.*, Vol. 115, C12035, 14 PP., doi:10.1029/2009JC005857.

## 18. CIMSS Participation in the JPSS Proving Ground/Risk Reduction Program

### 18.1 Advancing Hyperspectral Sounder Applications in the Direct-Broadcast Environment

**CIMSS Task Leader: Elisabeth Weisz**

**CIMSS Support Scientists: William L. Smith Sr., Kathy Strabala, Allen Huang**

**NOAA Collaborator: Mitch Goldberg**

**Budget: \$120,000**

#### NOAA Long Term Goals:

- Climate Adaptation and Mitigation
- Weather-Ready Nation

#### NOAA Strategic Goals:

- Serve society's needs for weather and water
- Understand climate variability and change to enhance society's ability to plan and respond
- Support the nation's commerce with information for safe, efficient and environmentally sound transportation
- Provide critical support for the NOAA mission

#### CIMSS Research Themes:

- Satellite Meteorology Research and Applications
- Satellite Sensors and Techniques
- Environmental Models and Data Assimilation
- Education and Outreach

#### Objective

Our objective is to increase the utility of hyperspectral sounding data products in meteorological real-time operations and to serve the direct-broadcast (DB) community by making the best possible data products available.

#### Project Overview

We aim to characterize hyperspectral (HS) retrieval software that is currently available to the national and international direct-broadcast (DB) user community through the UW/CIMSS Community Satellite Processing Package (CSPP). The main differences between the UW/CIMSS Dual-Regression (DR) retrieval algorithm and the NOAA Unique Combined Atmospheric Processing System (NUCAPS) and their implications on product quality and performance for a variety of atmospheric conditions (including severe weather) are investigated. Our main goal is to

promote and enhance the use of hyperspectral satellite data products in meteorological and environmental real-time applications.

### Milestones with Summary of Accomplishments and Findings

The main differences between the Dual-Regression retrieval algorithm (Smith et al., 2012; Weisz et al., 2013) and NUCAPS (Gambacorta et al., 2013) have been summarized and discussed by Weisz et al. (2015). We continued to explore case studies of various atmospheric conditions by studying the overall performance of the DR and NUCAPS hyperspectral retrievals with the focus on the atmospheric destabilization associated with the convective development of severe local storms. We found that stability parameters derived from hyperspectral sounder temperature and humidity profiles provide additional diagnostic information to aid the warning and decision-making process during severe weather events. Figure 71 shows NUCAPS and DR retrievals of the dewpoint temperature at 500 hPa pressure level as well as temperature profile retrievals in comparison with a radiosonde observation at one specific location on 11 May 2016 around 1930 UTC.

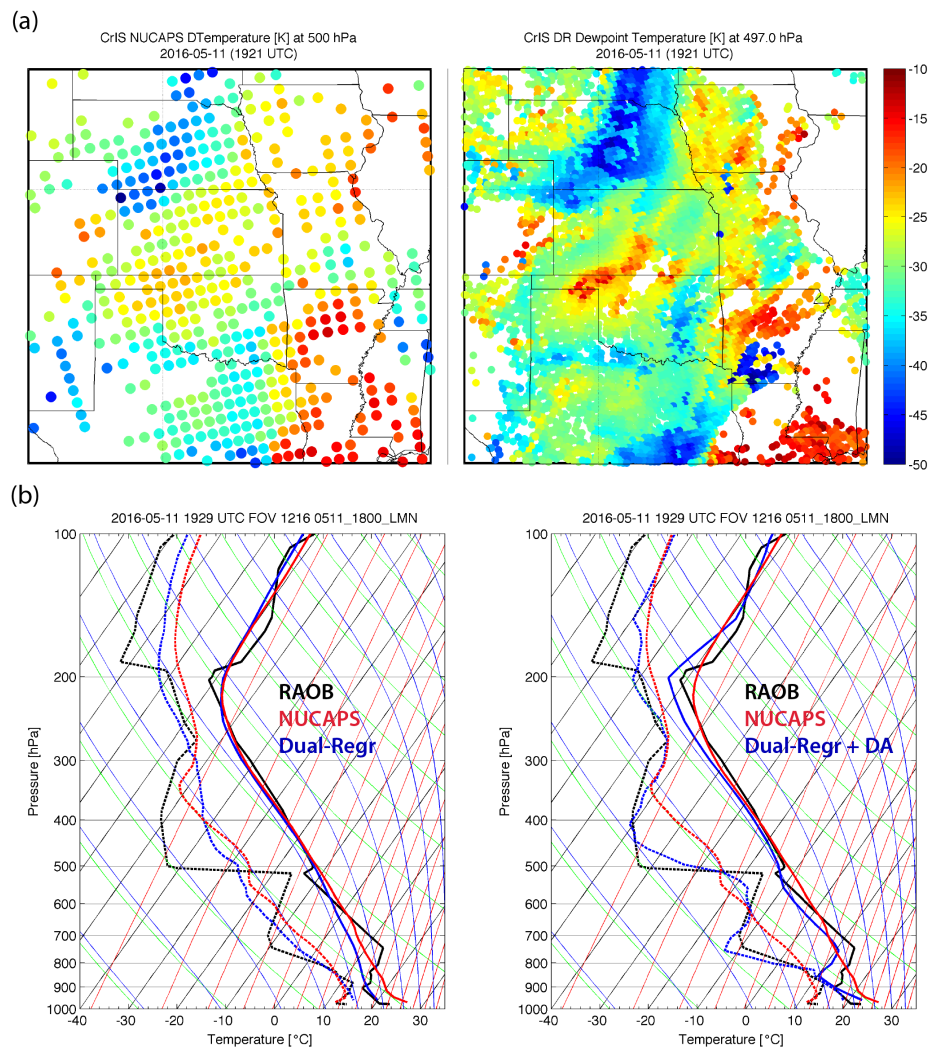
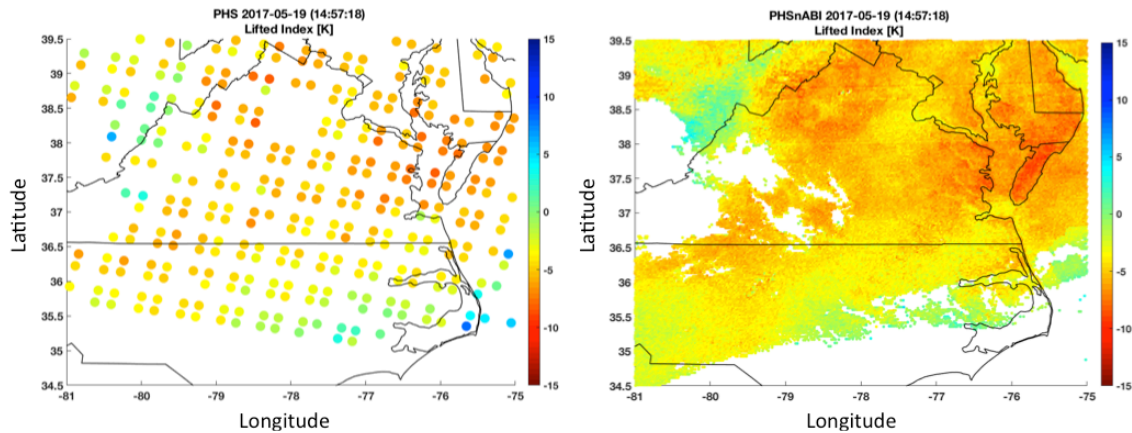

**Figure 71. (a) NUCAPS (left) and Dual-Regression (right) derived dewpoint temperature at 500 hPa. (b) Skew-T plots of a radiosonde observation (RAOB) at Lamont, OK at 1800 UTC on 11 May 2015 (black), co-located NUCAPS (red) and Dual-Regression (blue, left panel) and DR+De-Aliasing (DA) retrievals (blue, right panel).**



If the DR profile retrievals are used in NWP (Numerical Weather Prediction) data assimilation the vertical alias due to limited vertical resolution of satellite soundings needs to be removed prior the assimilation process. The vertical alias is the difference between a model profile (e.g., Global Data Assimilation System, Rapid Refresh) and the simulated profile retrieval, which is derived from simulated radiances. This so-called De-Aliasing (DA) correction (Smith and Weisz 2017) produces profiles, which show improved fine-scale vertical temperature and humidity features (Figure 71, bottom) consistent with radiosonde observations and forecast model background fields. Therefore a positive impact on NWP prediction is expected when retrieval profiles like the DR+DA soundings shown here are assimilated in NWP models.

Nevertheless, the temporal and horizontal resolution of polar-orbiting hyperspectral sounders may limit the performance of severe weather monitoring applications. A recently developed method for combining data from the polar HS sounders with data from the ABI (Advanced Baseline Imager) on geostationary platforms optimizes the overall resolution of the satellite-sounding product by providing the spatial and temporal detail needed to improve severe convection prediction.



**Figure 72. Lifted Index derived from polar hyperspectral soundings (left) and from a combination of the PHS and GOES-16 ABI data (right) for 19 May 2017 (~1500 UTC).**

Figure 72 shows a comparison between the Lifted Index (LI) derived from polar HS soundings (PHS) - in this example from the Infrared Atmospheric Sounding Interferometer or IASI - and the LI derived from the PHS+ABI sounding retrievals for 19 May 2017 around 1500 UTC. One can see how the combined product provides the absolute accuracy of the PHS soundings but with the horizontal resolution of the ABI instrument. This combination technique can be used to provide 15-minute time resolution of PHS+ABI sounding products, enabling timely observations of stability indices to support severe weather nowcasting and forecasting operations.

### Publications and Conference Reports

Smith, W. L., E. Weisz, J. McNabb, M. Dutter, Hampton University Direct Broadcast Satellite Sounding Products, 2017 NOAA Satellite Conference, City College New York, NY 17–20 July 2017.

Smith, W. L., D. Tobin, E. Weisz, J. Taylor, H. Revercomb, R. Knuteson, On the dependence of satellite Soundings on instrument field-of-view size, EUMETSAT 2017 Meteorological Satellite Conference, 2–6 October 2017, Rome, Italy.



Smith, W. L., and E. Weisz (2017), Dual Regression Approach for High Spatial Resolution Infrared Soundings, published in *Comprehensive Remote Sensing*, M. Goldberg, Editor, Elsevier Ltd, Langford Lane Oxford, OX5 1GB UK.

Smith, W. L., E. Weisz, J. McNabb, Combining Polar Hyper-spectral and Geostationary Multi-spectral Sounding Data –A Method to Optimize Sounding Spatial and Temporal Resolution, 21th International TOVS Study Conference (ITSC-XXI), 29 November–5 December 2017, Darmstadt, Germany.

Weisz, E., W. L. Smith Sr., K. Strabala, A. Huang, N. Smith, Hyperspectral Sounder Derived Severe Weather Indices, 21th International TOVS Study Conference (ITSC-XXI), 29 November–5 December 2017, Darmstadt, Germany.

Smith, W. L., E. Weisz, J. McNabb, Combining Direct Broadcast Polar Hyper-spectral Soundings with Geostationary Multi-spectral Imagery for Producing Low Latency Sounding Products, AGU Fall Meeting 2017, 11–15 December 2017, New Orleans, Louisiana.

## References

Gambacorta, A., et al. (2013), The NOAA Unique CrIS/ATMS Processing System (NUCAPS): Algorithm Theoretical Basis Documentation, Version 1.0, NOAA Center for Weather and Climate Prediction (NCWCP), 5830 University Research Court 2nd Floor, Office 2684 College Park, MD 20740-3818, USA.

Smith, W. L., E. Weisz, S. Kirev, D. K. Zhou, Z. Li, and E. E. Borbas (2012), Dual-Regression Retrieval Algorithm for Real-Time Processing of Satellite Ultraspectral Radiances. *J. Appl. Meteor. Clim.*, 51, Issue 8, 1455-1476.

Smith, W. L., and E. Weisz (2017), Dual Regression Approach for High Spatial Resolution Infrared Soundings, published in *Comprehensive Remote Sensing*, M. Goldberg, Editor, Elsevier Ltd, Langford Lane Oxford, OX5 1GB UK.

Weisz, E., W. L. Smith, and Nadia Smith (2013), Advances in simultaneous atmospheric profile and cloud parameter regression based retrieval from high-spectral resolution radiance measurements. *Journal of Geophysical Research -Atmospheres*, 118, 6433-6443.

Weisz, E., W. L. Smith, N. Smith (2015), Assessing Hyperspectral Retrieval Algorithms and their Products for Use in Direct Broadcast Applications, 20th International TOVS Study Conference (ITSC-XX) proceedings paper 3.03, 28 October - 3 November 2015, Lake Geneva, Wisconsin, USA.

## 18.2 Enhance the Utilization of Real Time JPSS Sounder Data in SDAT for Tropical Cyclone Forecast Application

**CIMSS Task Leader: Jun Li**

**CIMSS Support Scientists: Jinlong Li, Kevin Baggett, and Pei Wang**

**NOAA Collaborators: Mark DeMaria, and John L. Beven, Vijay Tallapragada, Andrew Collard**

**Budget: \$130,000**



### **NOAA Long Term Goals:**

- Climate Adaptation and Mitigation
- Weather-Ready Nation

### **NOAA Strategic Goals:**

- Serve society's needs for weather and water
- Support the nation's commerce with information for safe, efficient and environmentally sound transportation
- Provide critical support for the NOAA mission

### **CIMSS Research Themes:**

- Satellite Meteorology Research and Applications
- Satellite Sensors and Techniques

### **Objective**

The objective is to enhance the utilization of near real-time JPSS series CrIS radiance measurements for tropical cyclone forecast application.

### **Project Overview**

The team propose to enhance the utilization of real time JPSS (Suomi NPP, JPSS1, JPSS2) sounder data in CIMSS Satellite Data Assimilation for Tropical storm forecast (SDAT) system (<http://cimss.ssec.wisc.edu/sdat>) while meeting the latency for tropical cyclone (TC) forecast application by increasing the model horizontal resolution, using TC vital observations to improve the hurricane location initialization, and implementing the latest version of Community Gridpoint Statistical Interpolation (GSI) data assimilation system. SDAT will serve as the testbed to conduct research on improving the utilization of JPSS data, and the research topics include: better CrIS sub-pixel clear detection by using collocated high spatial resolution VIIRS cloud mask, which has been successfully demonstrated using AIRS/MODIS (Wang et al. 2014); CrIS radiance assimilation in cloudy regions (Wang et al. 2015; 2017); impact study on assimilating Unique CrIS/ATMS Processing System (NUCAPS) soundings and cloud-cleared radiances (CCRs), and impact study on assimilating the full spectral resolution CrIS water vapour absorption band radiances. The research progress will be implemented in SDAT for real time demonstration and TC forecast application. In addition, the research progress made with SDAT on JPSS sounder assimilation will also be tested with benchmark HWRF at STAR's supercomputer S4/Cardinal located at Space Science and Engineering Center (SSEC). CIMSS scientists will collaborate with Environmental Modelling Center (EMC) on possible transition of the research progress made by this project to operational HWRF.

CIMSS has been making the SDAT forecast products accessible in near real time (NRT) since September 2014 to ATCF (automatic tropical cyclone forecast) system that National Hurricane Center (NHC) uses. CIMSS scientists will collaborate with NHC on the application of SDAT products and get feedback/guidance from users for further improvement on JPSS sounder data assimilation and SDAT system.

### **Milestones with Summary of Accomplishments and Findings**

#### ***VIIRS-based CrIS cloud-clearing (CC) algorithm refined, CrIS cloud-cleared radiances (CCRs) reprocessed and successfully tested with SDAT***

The re-processed CrIS CCRs with refined algorithm have been further tested with SDAT, two typical cases: hurricane Joaquin (2015) and Hurricane Matthew (2016) were tested using CrIS



CCRs. Results show that for some situations the CrIS CCRs provided critical needed observations in cloudy skies for improving track and intensity forecasts. Figure 73 shows the 7 groups of the forecasts (120-hour) after re-run. It shows consistent improvement from using CrIS CCRs.

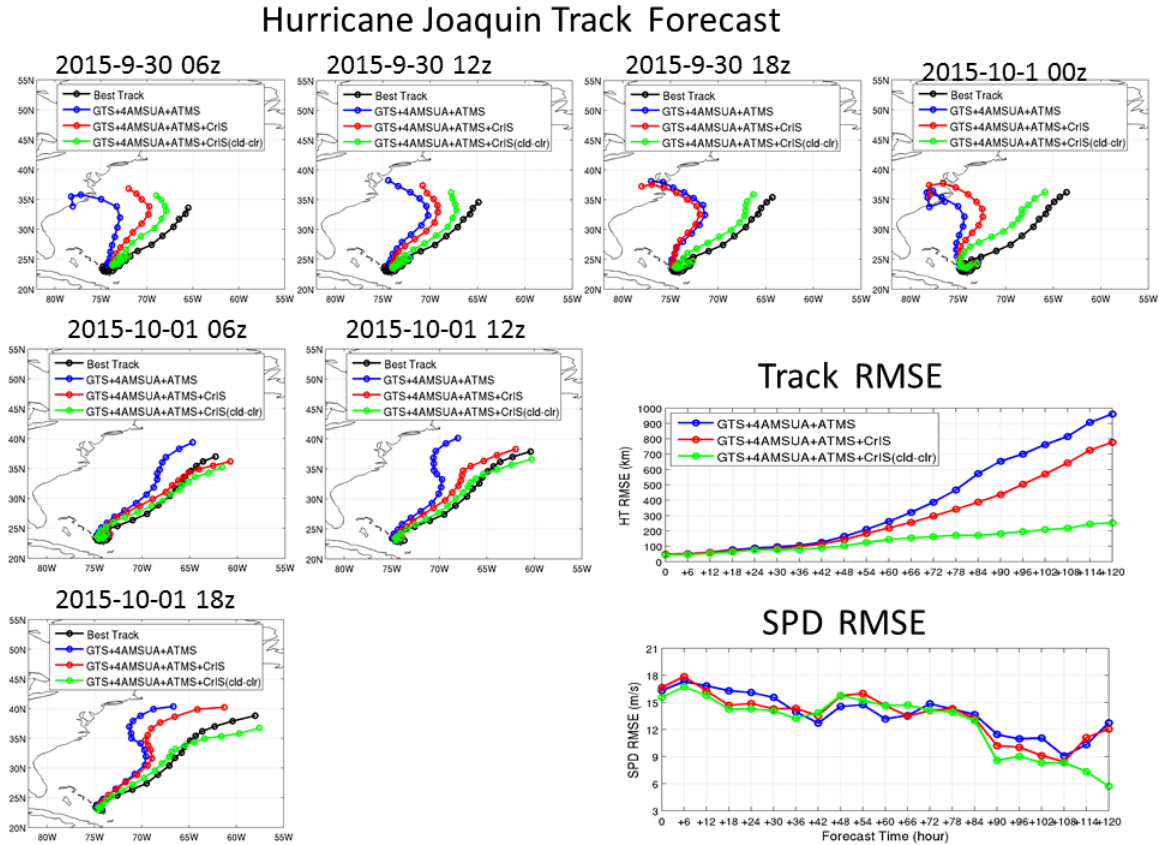

Figure 73. Seven groups of the 120-hour forecasts after re-run on assimilation of reprocessed CrIS CCRs with refined algorithm. Black: best estimate (observations); Blue: using conventional data from GTS, 4 AMSU-A and ATMs; Red: conventional data, 4 AMSU-A, ATMS and CrIS clear radiances (GSI approach); green: same as red but using CrIS CCRs instead of CrIS clear radiances only.

### ***VIIRS-based CrIS cloud-cleared radiances assimilated in GFS for impact assessment***

Following methodology developed by Li et al. (2005), the imager-based IR sounder cloud-clearing techniques and procedures have been modified to apply to process the collocated VIIRS/CrIS. One month of global CrIS cloud-cleared radiance dataset has been processed and provided to EMC for evaluation. The VIIRS based CrIS CCR assimilation experiments in GFS have been conducted by EMC. The parallel experiments have been conducted by EMC using the CCRs CIMSS provided to test the impact of the CCRs on the global analysis and forecasts in EMC system. The experiments cover the month of October in 2015. Initial results show that the impact is neutral globally in terms of the anomaly correlation (AC) of the height, temperature fields for all the levels. Fit-to-obs (rawinsonde) plots basically show no difference between the experiments with or without CCRs. There is no amplification factor applied to the CCRs data yet since the data CIMSS provided me do not include the amplification factor. More ACs or fit-to-obs are under analysis in addition to the example plots. Figure 74 shows the two example plots. The first is the AC scores for temperature field at 250 mb 5-day forecast from Oct.6 to Oct.30,



2015. The black curve is the control run which does not include the CCRs while the other two curves are using CCR but having different thinning criteria. The second plot is the fit-to-obs from the control and one experiment with CCR data.

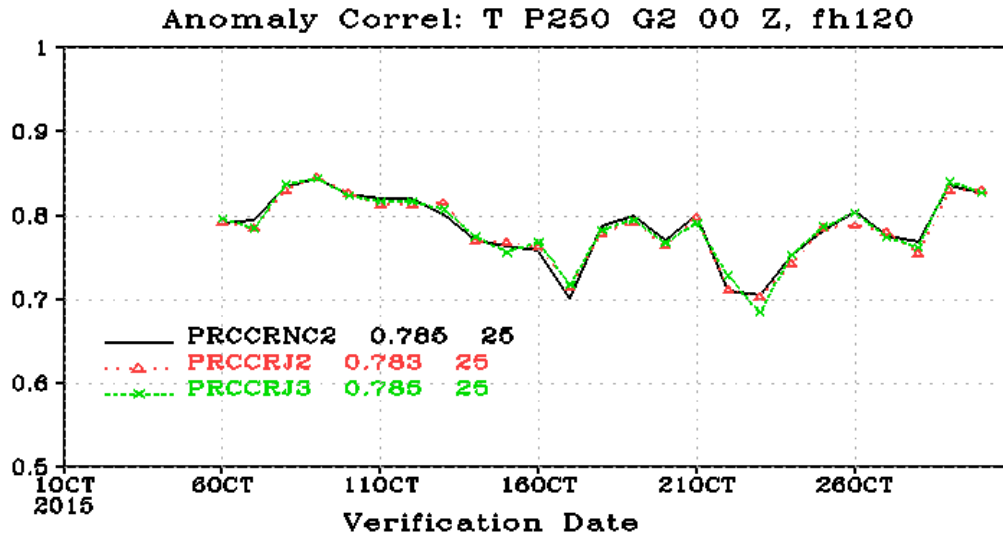
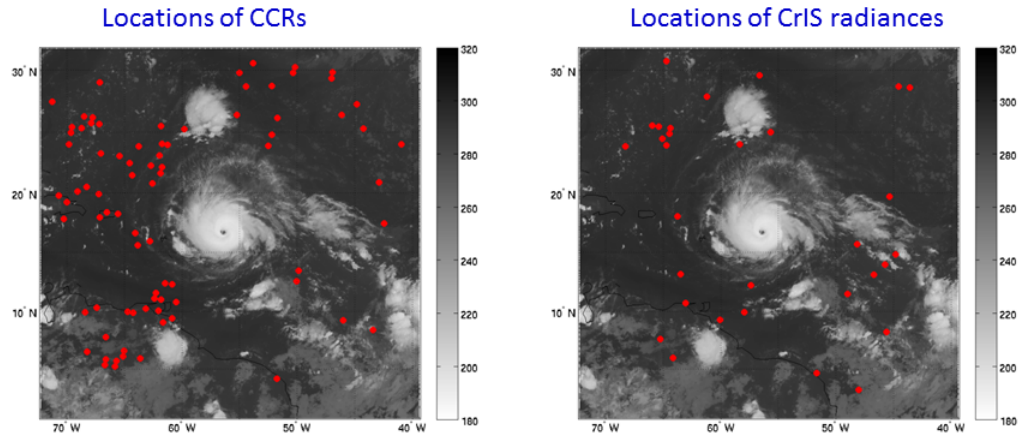

Figure 74. AC for 250 hPa from parallel GFS experiments on CrIS radiance and CCR assimilation (Figure from EMC).

EMC standard verification package of the global forecast system is used for the plots, which is used by EMC for data impact at EMC. Improvement on CCR assimilation in GFS is ongoing with focus on quantification of CCR uncertainty.

**CrIS CCRs are converted to the format GSI can ingest and the assimilation experiments with HWRF started.**

In order to further compare the CrIS radiance assimilation and CrIS CCR assimilation in NOAA operational NWP model such as HWRF, the first step is to convert the CrIS CCRs to BUFR format that GSI can assimilate them into HWRF. This step has been finished and the CCRs are now being tested with HWRF. Figure 75 shows the CrIS CCRs assimilated into HWRF and the original CrIS radiances assimilated into HWRF (Hurricane Irma case) for CrIS channel 96 (14.10  $\mu\text{m}$ ). The locations are overlaying on GOES-16 ABI 11  $\mu\text{m}$  brightness temperature (BT) image. The assimilation experiments are ongoing at S4 physically located at SSEC, impact from CCRs are expected to be available very soon.



**Figure 75.** The CrIS CCRs assimilated into HWRF and the original CrIS radiances assimilated into HWRF (Hurricane Irma case) for channel 96 (14.10  $\mu\text{m}$ ).

### **Publications and Conference Presentations**

Li, J., et al., 2018: Value-added impact from geostationary hyperspectral infrared sounding on nowcasting and forecasting high-impact weather events, 98th American Meteorological Society Annual Meeting, 07 – 12 January 2018, Austin, TX.

Li, Jun et al., 2017: Impact of assimilating the VIIRS-based CrIS cloud-cleared radiances on hurricane forecasts, the 21st International TOVS Study Conference (ITSC-21), Darmstadt, Germany, 28 November – 05 December 2017.

Wang Pei, Jun Li, Z. Li, A. H. N. Lim, Jinlong Li, T. J. Schmit, and M. D. Goldberg, 2017: The Impact of Cross-track Infrared Sounder (CrIS) Cloud-Cleared Radiances on Hurricane Joaquin (2015) and Matthew (2016) Forecasts, *Journal of Geophysical Research - Atmospheres*, 122, DOI: 10.1002/2017JD027515.

Wang, Pei, Jun Li, Zhenglong Li, Jinlong Li, Agnes Lim, Jung-Rim Lee, Tim Schmit and Mitchell Goldberg, 2018: Impact of Assimilating the CrIS Thermodynamic Information in Cloudy Skies on Hurricane Forecasts, 98th American Meteorological Society Annual Meeting, 07 – 12 January 2018, Austin, TX.

### **18.3 High Resolution Trajectory-Based Smoke Forecasts using VIIRS Aerosol Optical Depth and NUCAPS Carbon Monoxide Retrievals**

**CIMSS Task Leader: James E Davies**

**CIMSS Support Scientists: Kathy Strabala, Russ Dengel**

**NOAA Collaborator: R. Bradley Pierce**

**Budget: \$133,000**

#### **NOAA Long Term Goals:**

- Weather-Ready Nation

#### **NOAA Strategic Goals:**

- Serve society's needs for weather and water



### **CIMSS Research Themes:**

- Satellite Meteorology Research and Applications
- Environmental Models and Data Assimilation

### **Objective**

This work addresses the need for low latency, web-based, high resolution forecasts of smoke dispersion for use by NWS Incident Meteorologists (IMET) to support on-site decision support services for fire incident management teams.

### **Project Overview**

This project supports the Fire and Smoke (F&S) and Sounding Applications (NUCAPS, Atmospheric Chemistry) Initiatives of the 2016 Joint Polar Satellite System (JPSS) Proving Ground and Risk Reduction (PGRR) Program by using Visible Infrared Imaging Radiometer Suite (VIIRS) Aerosol Optical Depth (AOD) and combined Cross-track Infrared Sounder (CrIS) and Advanced Technology Microwave Sounder (ATMS) NOAA-Unique Combined Atmospheric Processing System (NUCAPS) carbon monoxide (CO) retrievals to initialize trajectory-based, high spatial resolution North American smoke dispersion forecasts.

### **Milestones with Summary of Accomplishments and Findings**

A beta version of the VIIRS high resolution (HR) AOD trajectory forecast with the Enterprise AOD algorithm was delivered to colleagues at the Atmospheric Sciences Research Center (ASRC) of the University of Albany, State University of New York (SUNY). The software generates air quality forecast products from input S-NPP VIIRS data, downloaded input satellite and ancillary data files and the execution of which can be automated using the unix cron scheduler.

Figure 76 shows the IDEA-I VIIRS HR AOD trajectory initialization on September 04 and 24 hour forecast on September 05, 2017. The high AOD values over Southern Wisconsin, Illinois, and Michigan are associated with long-range transport of smoke from wildfires in the western US. The 24hr trajectory forecast predicts that this smoke will be transported to the NE into upstate New York. Indeed doppler wind lidar S/N ratios from the New York State Energy Research and Development Authority (NYSERDA) Mesonet confirmed the arrival of smoke between 12Z on September 05 and 00Z on September 06, 2017 between the altitudes of 0.5 and 1.5 km (not shown).

During this reporting period we began testing a beta version of the real-time trajectory-based NUCAPS intercontinental pollution forecast capabilities under CSPP. The NUCAPS carbon monoxide (CO) forecast is now available in near-real-time for both SNPP and J01 platforms at: <http://smoke.ssec.wisc.edu/idea-i-carbonmonoxide-live-test/index.php> and will be used by federal and state air quality management agencies to monitor regional and long-range transport of pollution. Figure 77 shows NUCAPS CO retrievals and trajectory forecasts from both SNPP AM (6:26-8:56Z) orbits on March 27, 2018. NUCAPS AM CO retrievals show enhanced (>200ppbv) CO at 815mb over Eastern Texas and Southern Louisiana associated with the agricultural fires from the previous day. 10 hour NUCAPS CO trajectory forecasts valid at 18Z on March 27, 2017 (right panel) show that this enhanced CO is transported to the NNE over Arkansas and Mississippi and remains within the boundary layer. Surface PM<sub>2.5</sub> Air Quality Index (AQI) maps from the US EPA AIRNow website separately confirmed that SE Arkansas and Mississippi experienced moderate aerosol pollution on March 27, 2018.



VIIRS AOD & AOD Trajectories on 2017-09-05 18Z

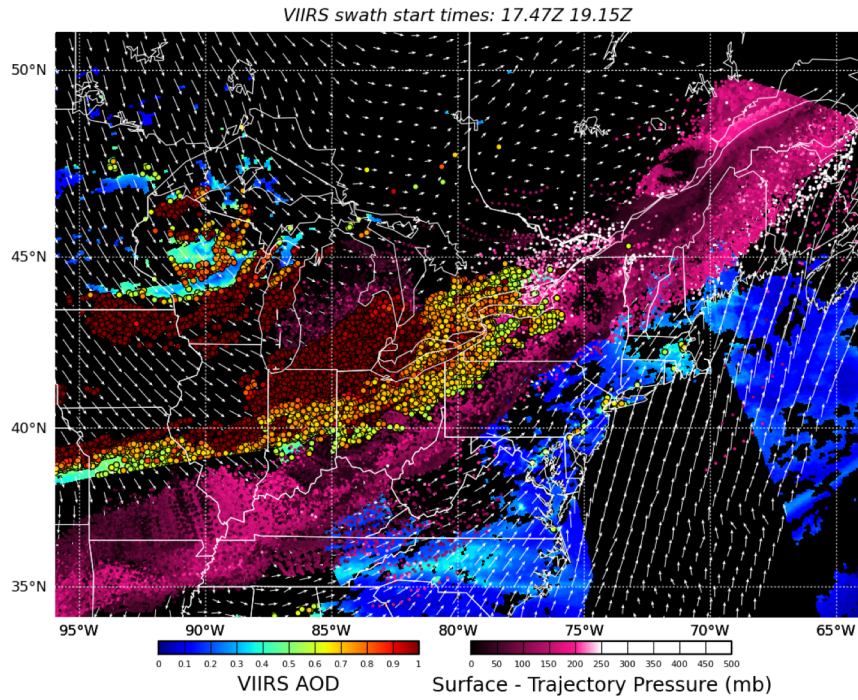

Figure 76. 24hour forecast for VIIRS High Resolution trajectories over the NE US initialized on September 04, 2017.

NUCAPS Carbon Monoxide & CO Trajectories on 2018-03-27 08Z

NUCAPS Carbon Monoxide & CO Trajectories on 2018-03-27 18Z

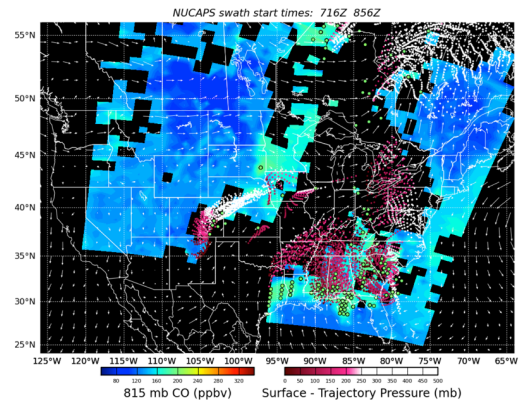
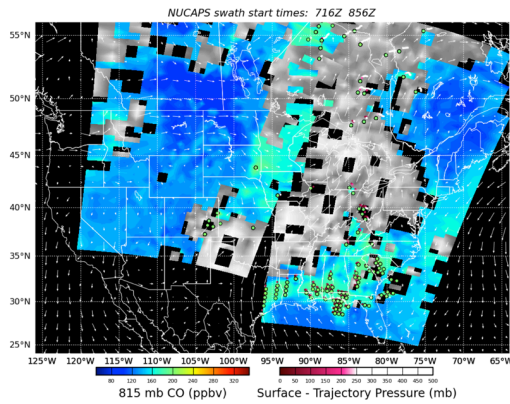

Figure 77. Real-time SNPP NUCAPS CO Trajectories initialized on March 27, 2018 (left panel) and 10 hour forecast valid at 18Z (right panel) on March 27, 2018.

**Publications and Conference Reports**

Nadia Smith (STC) presented “Improving the design of NUCAPS trace gas products within applications – The value of a user-developer partnership” at the EUMETSAT Meteorological Satellite Conference on 2-6 October, 2017 in Rome, Italy.





## **18.4 The Cold Air Aloft Aviation Hazard: Its Detection Using Observation from the JPSS**

**CIMSS Task Leader: Robert Knuteson**

**CIMSS Support Scientists: Dave Hoese, Kathy Strabala**

**NOAA Collaborator: Kristine Nelson (NOAA/CWSU)**

**Budget: \$5,000**

### **NOAA Long Term Goals:**

- Weather-Ready Nation
- Resilient Coastal Communities and Economies

### **NOAA Strategic Goals:**

- Serve society's needs for weather and water
- Support the nation's commerce with information for safe, efficient and environmentally sound transportation
- Provide critical support for the NOAA mission

### **CIMSS Research Themes:**

- Satellite Meteorology Research and Applications
- Satellite Sensors and Techniques
- Environmental Models and Data Assimilation

### **Objective**

This proposal is responsive to JPSS Initiative #5 (Sounding Applications; sub-bullet #1) and secondarily responsive to JPSS Initiative #7 (OCONUS and NCEP Service Centers AWIPS; sub-bullet #4). The primary objectives of this proposal are as follows:

- 1) Develop and disseminate gridded real-time CrIS/ATMS products through DB;
- 2) Generate new AWIPS II visualization capabilities with gridded products for 3-D visualization of CrIS/ATMS profile data;
- 3) Transition experimental product to Alaska CWSU and perform targeted assessment to determine operational utility of product for CAA forecast challenge; and
- 4) Identify and investigate other forecast challenges outside of CAA where similar visualizations may be beneficial.

### **Project Overview**

The NOAA/NWS CWSU in Anchorage, Alaska has forecast responsibilities for disseminating text-based products to pilots and airlines, which give guidance on the latitude/longitude bounds and vertical flight levels of these cold air aloft (hereafter CAA) regions where the air temperature is at or below  $-65^{\circ}\text{C}$ . Previously, forecasters at the CWSU would rely on a combination of isolated aircraft reports, a sparse network of radiosondes, and global model fields for identifying and characterizing these cold air hazards. However, these current datasets have proven spatially and vertically insufficient for the accurate characterization of the three-dimensional (3-D) nature of these CAA features. Forecasters have expressed an urgent need for additional data to be added to fill observational gaps and/or confirm information that is seen in models (i.e., to build confidence in numerical CAA predictions). One source of observations that has remained largely unused but promises to add great value is temperature soundings from hyperspectral infrared (IR) instruments onboard polar-orbiting satellites. Decision support systems have traditionally been used to visualize observations from space-based imagers as two-dimensional (2-D) surface plots (e.g., a cloud field). Satellite soundings, however, offer 3-D characterization of the atmosphere



(latitude, longitude, and height) that can potentially improve forecasting skill in general and the characterization of these CAA regions specifically.

## **Milestones with Summary of Accomplishments and Findings**

### ***Develop and Disseminate Gridded CrIS/ATMS Products through Direct Broadcast***

The Dual Regression Retrieval (DR) and Polar2Grid software tools have been available within CSPP for more than two years. At present, the DB site at GINA (U. Alaska) runs CSPP in real-time and disseminates products via File Transfer Protocol (FTP). NUCAPS, the NOAA operational CrIS/ATMS processing algorithm, was released within CSPP at the end of February 2015. GINA receives CrIS/ATMS data from the S-NPP satellite via DB antennas at the University of Alaska campus in Fairbanks and at the NOAA Satellite and Information Service (NESDIS) Command and Data Acquisition Station at Gilmore Creek, Alaska. We successfully implemented the NUCAPS retrieval products at GINA by using the CSPP software to process the data and generate products depicting the CAA phenomenon in formats ready for ingest into AWIPS II.

UW-CIMSS provided critical support for the adaptation of Polar2Grid software for use with the NUCAPS product. A list of accomplishments from the previous year are provided below:

- This project funded new features, software bug fixes, and software maintenance in the form of testing, documentation, updating third-party libraries, and software packaging of official Polar2Grid releases.
- Initial work added ability to read NUCAPS retrieval NetCDF4 files via a NUCAPS "Reader."
- The Reader could produce Temperature (Temperature) and H2O Mixing Ratio (H2O\_MR) data that was then resampled to a uniform grid and written to an HDF5 file via Polar2Grid.
- Resampling was done using a nearest neighbor resampling algorithm.
- HDF5 files were then used by SPORT to view the data in AWIPS and other tools.
- Feature: Ability to mask data below the surface pressure.
- Feature: Ability to mask data based on NUCAPS quality flags.
- Feature: Ability to specify which pressure levels to produce.
- NUCAPS reading was a challenge for Polar2Grid as it was the first pressure-based products it had ever had to read.
- Second round of work added "Skin\_Temperature", "Surface\_Pressure", and "Topography" to produced output.
- The ability to turn off the above-mentioned masking functionality was also added.
- Additional work was done to add fields that may be used in the future.
- The NUCAPS functionality added to Polar2Grid was done so via the open source python library SatPy in collaboration with the PyTroll group. It can be accessed in SatPy using the reader name "uncaps."
- By adding the NUCAPS Reader to SatPy we benefit from many developers reviewing the code, more testers, more users, and reduced redundancy of code. We also benefit from any features or optimizations that may be contributed to the project; even when it isn't added specifically for the NUCAPS Reader.
- Polar2Grid and SatPy (as well as other PyTroll python packages) are hosted on the online project hosting service GitHub (github.com) and are available to the public.
- Funding was used to add "unit tests" to SatPy and Polar2Grid to help insure that changes to the software keep the NUCAPS functionality working as the software grows and new



- features get added. Unit tests are run automatically after every change that is made to the software via the Continuous Integration service TravisCI ([travis-ci.org](https://travis-ci.org)).
- In addition to unit testing the SatPy package takes advantage of the Coveralls service ([coveralls.io](https://coveralls.io)) to report on how much of the code is being actively tested. It reports this as a percentage of code lines "touched" during testing. This helps to inform the development team and users of the stability of the SatPy project. Since SatPy is a rather new project every new test helps.
  - The SatPy python library is available to python developers via the PyPI (Python Package Index) (<https://pypi.python.org/pypi/satpy>). This allows for easy installation for any developers familiar with the Python programming language.
  - SatPy and Polar2Grid are written in the Python programming language with command line helper scripts written in bash. They both take advantage of third-party libraries like NumPy and SciPy for fast calculations as well as some custom code written in the Cython programming language to produce C/C++ code for the best performance in key areas of the processing.

During the current contract period, the SSEC staff provided technical programming support to the joint project lead by NASA SPORT. The CSPP Polar2Grid software was updated to support additional NUCAPS fields including solar zenith angle and various mixing ratios. Other changes to code were made to keep the NUCAPS-specific software up to date with the rest of Polar2Grid and improve the handling of the NUCAPS quality flags for masking invalid data.

## References

Gambacorta, A, 2014: *The NOAA Unique CrIS/ATMS Processing System (NUCAPS): Algorithm Theoretical Basis Documentation*, NOAA/NESDIS/STAR, 72 pp.

## 18.5 A Fused SO<sub>2</sub> Analysis from JPSS

**CIMSS Task Leader: John Cintineo**

**CIMSS Support Scientists: Justin Sieglaff, Jason Brunner**

**NOAA Collaborator: Michael Pavolonis**

**Budget: \$129,000**

### NOAA Long Term Goals:

- Climate Adaptation and Mitigation
- Weather-Ready Nation

### NOAA Strategic Goals:

- Serve society's needs for weather and water
- Understand climate variability and change to enhance society's ability to plan and respond
- Provide critical support for the NOAA mission

### CIMSS Research Themes:

- Satellite Meteorology Research and Applications
- Satellite Sensors and Techniques

### Objective

Develop robust methods for the detection of SO<sub>2</sub> by fusing together data from instruments aboard polar-orbiting satellites for weather and climate applications.



## Project Overview

SO<sub>2</sub> is an abundant volcanic gas that is hazardous to human health, infrastructure and the environment, and is often a very effective tracer for volcanic ash, which is a major aviation hazard. In addition, regular monitoring of volcanic SO<sub>2</sub> emissions can help scientists better characterize volcanic unrest, forecast eruption, and assess the climate impacts of very large eruptions. Despite the importance of SO<sub>2</sub> monitoring, JPSS is severely underutilized for this application, and the existing single sensor JPSS SO<sub>2</sub> products from OMPS and CrIS have several important limitations. The goal of the proposed cross-cutting research, to be conducted over the course of 3 years, is to create a far more capable fused SO<sub>2</sub> product suite using VIIRS, CrIS, and OMPS. Users will benefit from the strengths of three sensors integrated into a single coherent product line, eliminating the need to try to manually blend all of the “stove piped” information. The primary users for the proposed products are Volcanic Ash Advisory Centers (VAAC’s), Meteorological Watch Offices (MWO’s), volcano observatories (including the USGS Alaska Volcano Observatory (AVO)), and the Air Force Weather Agency (AWFA).

## Milestones with Summary of Accomplishments and Findings

JPSS SO<sub>2</sub> detection has been incorporated into the VOLcanic Cloud Analysis Toolkit (VOLCAT) alerting system. The SO<sub>2</sub> detection capabilities developed under this project were integrated into the VOLCAT automated alerting tool. The automated alerting tool utilizes cloud object properties to identify volcanic cloud features (e.g. Pavolonis et al., 2015a; Pavolonis et al., 2015b) and generate alerts for users via email and SMS (text message). Each alert includes a hyperlink to an online alert report that contains additional details and relevant JPSS imagery.

The combination of CrIS and VIIRS is currently used to generate the SO<sub>2</sub> alerts. An example SO<sub>2</sub> alert is shown in Figure 78.

The VOLCAT website was updated to allow for future distribution of JPSS based SO<sub>2</sub> alerts to users. Further, the quality of the alerts will improve as progress is made on integrating OMPS and improving the overall data integration scheme.

The VOLCAT plume-fitting algorithm, originally developed for volcanic ash clouds, was adapted for automatically identifying volcanic SO<sub>2</sub> plumes captured by VIIRS/ The plume-fitting algorithm has many tunable parameters that will continue to be refined.

We developed a method to co-locate OMPS and VIIRS, which will enable the quantification of SO<sub>2</sub> plumes using OMPS. The method utilizes the orbital parameter based co-location technique developed at the University of Wisconsin Space Science and Engineering Center (SSEC), in combination with the lat/lon of the OMPS pixel corners, to determine which VIIRS pixels fall into a given OMPS footprint. The co-location procedure is critical for integrating OMPS into the existing VIIRS/CrIS based SO<sub>2</sub> detection scheme.

A VIIRS/CrIS based SO<sub>2</sub> property (height and loading) retrieval scheme was prototyped using high spectral resolution radiative transfer model simulations. The radiative transfer model simulations were necessary for choosing the best CrIS channel subset and for characterizing retrieval sensitivities. The next step is to implement the retrieval on actual JPSS measurements.



### Volcanic Cloud Alert Report

Date:	2017-09-04
Time:	19:00:00
Production Date and Time:	2018-01-24 16:21:30 UTC
Primary Instrument:	NPP VIIRS

[More details ▼](#)

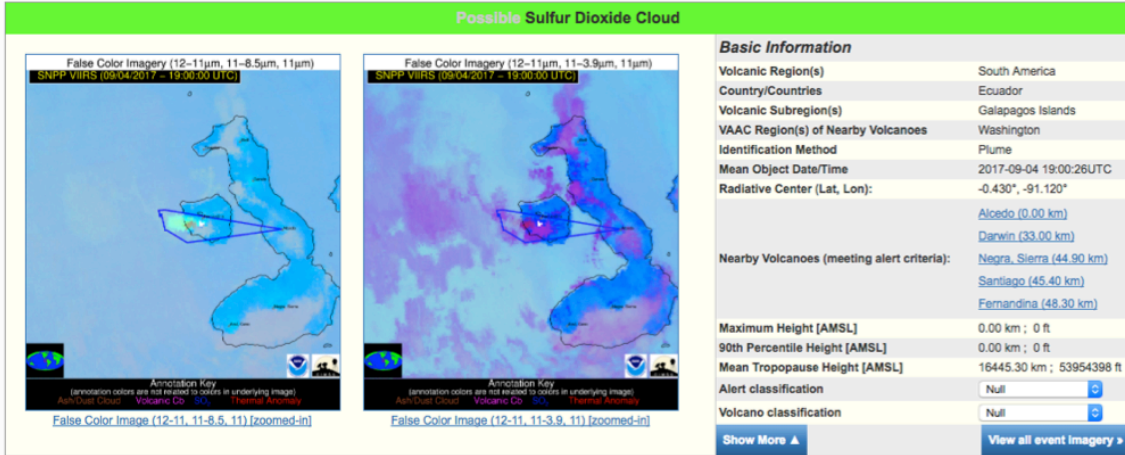

Figure 78. A sample SO<sub>2</sub> alert from the NOAA/CIMSS Volcanic Clouds webpage (<http://volcano.ssec.wisc.edu>), produced by the VOLCAT system and captured by the SNPP VIIRS instrument. This alert shows an SO<sub>2</sub> plume emanating from the Fernandina volcano in the Galapagos Islands (yellow/green cloud in the left false color imagery, encapsulated by the automated blue polygon). Users are sent the alert link via email or SMS (text messaging).

### Publications and Conference Reports

STAR JPSS Annual Science Team Meeting, August 14–18, 2017 (College Park, MD);  
Presentation entitled: “Development of Multi-sensor JPSS SO<sub>2</sub> products for Volcanic Cloud Monitoring”

JPSS Science Meeting, November 8–9, 2017 (Vandenberg Air Force Base - Lompoc, CA);  
Presentation entitled: “JPSS Products: Meteorological and Volcanic Clouds”

Australian Bureau of Meteorology’s Annual Research Workshop, November 26 – December 6, 2017 (Melbourne, Australia); Presentation entitled: “Transforming Satellite Data to Products in the era of Big Data”

### References

Pavolonis, M.J. and A. Parker, 2010: GOES-R Advanced Baseline Imager (ABI) Algorithm Theoretical Basis Document for SO<sub>2</sub> Detection, [http://www.goes-r.gov/products/ATBDs/option2/Aviation\\_SO2\\_v1.0\\_no\\_color.pdf](http://www.goes-r.gov/products/ATBDs/option2/Aviation_SO2_v1.0_no_color.pdf).

Pavolonis, M. J., 2010: Advances in Extracting Cloud Composition Information from Spaceborne Infrared Radiances-A Robust Alternative to Brightness Temperatures. Part I: Theory. *Journal of Applied Meteorology and Climatology*, **49**, doi:10.1175/2010JAMC2433.1.

Pavolonis, M. J., J. Sieglaff, and J. Cintineo (2015a), Spectrally Enhanced Cloud Objects (SECO): A Generalized Framework for Automated Detection of Volcanic Ash and Dust Clouds using Passive Satellite Measurements, Part I: Multispectral Analysis, *J. Geophys. Res. Atmos.*, **120**, doi:[10.1002/2014JD022968](https://doi.org/10.1002/2014JD022968).



Pavolonis, M. J., J. Sieglaff, and J. Cintineo (2015b), Spectrally Enhanced Cloud Objects (SECO): A Generalized Framework for Automated Detection of Volcanic Ash and Dust Clouds using Passive Satellite Measurements, Part II: Cloud Object Analysis and Global Application, *J. Geophys. Res. Atmos.*, 120, doi:[10.1002/2014JD022969](https://doi.org/10.1002/2014JD022969).

## **19. CIMSS Participation in the 2017 JPSS Proving Ground/Risk Reduction Program**

### **19.1 Addressing NWS Desires for Cloud Cover Layers (CCL) and Sky Cover Products using VIIRS and CrIS**

**CIMSS Task Leader: Steve Wanzong**

**CIMSS Support Scientists: Yue Li, Andi Walther, and Steve Wanzong**

**NOAA Collaborator: Andrew Heidinger**

**Budget: \$65,000**

#### **NOAA Long Term Goals:**

- Weather-Ready Nation

#### **NOAA Strategic Goals:**

- Serve society's needs for weather and water
- Support the nation's commerce with information for safe, efficient and environmentally sound transportation
- Provide critical support for the NOAA mission

#### **CIMSS Research Themes:**

- Satellite Meteorology Research and Applications
- Satellite Sensors and Techniques

#### **Objective**

Apply the CCL product to SNPP/VIIRS, and extend the VIIRS cloud products to use a combined VIIRS + CrIS Level1b dataset.

#### **Project Overview**

Due to budget constraints, several GOES-R ABI products were reclassified from “baseline” to “future capability.” Cloud Cover Layer is one such product. In 2014, the NWS Operational Algorithm Team (NOAT) selected five future capability GOES-R ABI products to be transitioned to operations. Included are Cloud Cover Layer (CCL), Aerosol Particle Size, Ice Concentration, Ice Age/Thickness, and Ice Motion.

While this NOAT request was directed for GOES-R, these products have been successfully generated by applying the same algorithm to the SNPP/VIIRS sensor relevant to the OCONUS region. The VIIRS cloud information could provide complementary cloud type and emissivity input to the currently geostationary-only sky cover product, particularly for Alaska.

The current NOAT guidance is that CCL should report 6 cloud fractions at predefined flight levels (FLs), including the total cloud fraction. These 5 levels are surface to FL050 (where FL050 stands for 5 kft), FL050 to FL100, FL100 to FL180, FL180 to FL240, and FL240 to the top of the atmosphere (TOA). Additionally, convective and super-cooled cloud fraction needs to be assessed.



### Milestones with Summary of Accomplishments and Findings

The CCL code has been updated to compute cloud fraction closely related to supercooled water clouds following the NOAT requirements. In addition to all cloud fractions, the CCL algorithm is capable of providing the fractions of supercooled water clouds at five predefined flight levels (FLs), including the total fraction. Cloud mask, cloud type and cloud height retrieval products are required to provide inputs to the CCL algorithm. Supercooled water particles are a known danger to aircraft and warnings of the existence of these particles at each FL are important to the aviation community.

Figure 79 shows a false color RGB image and 11  $\mu\text{m}$  brightness temperature of a VIIRS granule. Also shown are the needed cloud type and cloud top height products for the CCL retrievals. This figure shows a large cold ice core surrounded by supercooled water particles. In Figure 80, the supercooled water fraction at each FL is shown, as well as the total fraction within each 10 km by 10 km box. The total supercooled fraction is the sum of those values at individual FL. This computation relies on the cloud type algorithm correctly identifying the phase of each pixel.

The ongoing work attempts to utilize the more accurate CALIPSO/CALIOP lidar phase information, to help compute the supercooled water probability at the cloud top directly for each VIIRS granule, and interpolate to different FLs. This is expected to generate a probabilistic value consistent with the NOAT requirement, and provide freedom for the users to interpret the values based on their needs.

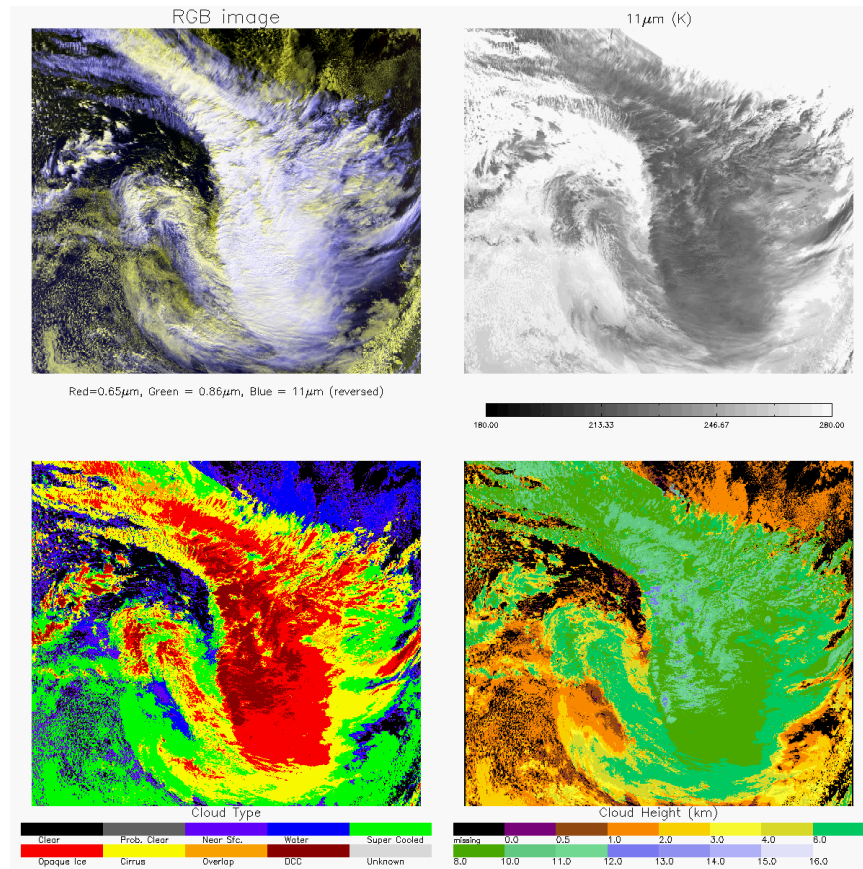
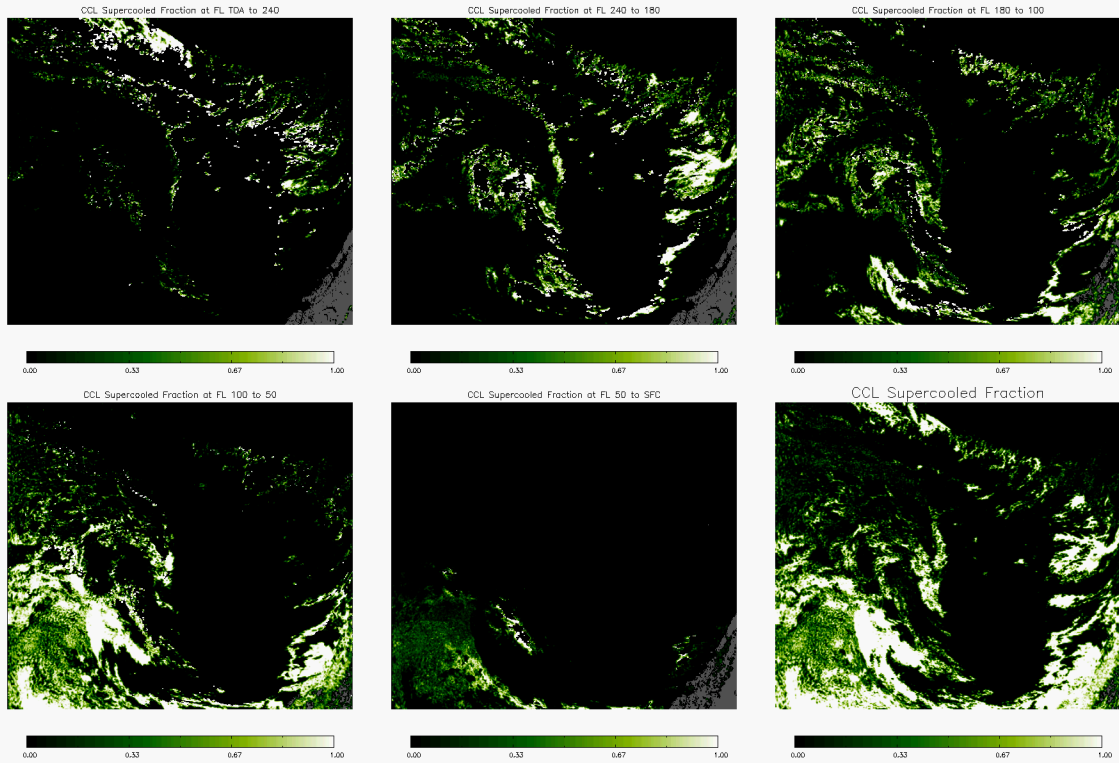

Figure 79. VIIRS granule on August 26, 2015 at 2004 UTC shows false color RGB (upper left), 11  $\mu\text{m}$  brightness temperature (upper right), cloud type (bottom left) and cloud top height (bottom right).



**Figure 80.** Same VIIRS granule as in Figure 79 shows supercooled water cloud fraction at each Flight Level (FL) and the total supercooled fraction (bottom right). The FL is indicated for each image.

The cloud team also completed the work on utilizing merged VIIRS-CrIS files to improve the cloud cover layer retrieval. The merged files have the advantage of using the high spectral resolution sounder data in concert with the high spatial resolution of VIIRS to improve the cloud, mask, type and height, thus benefiting the cloud cover layer work. A paper showing the improvement to ice cloud height retrievals by using the merged files has been submitted (Heidinger et al. 2018).

### **Publications and Conference Reports**

Heidinger, A. K, and coauthors, 2018: Using Sounder Data to Improve Cirrus Cloud Height Estimation from Satellite Imagers. *Submitted to JTECH*.

### **19.2 Strengthening TPW visualization in the OCONUS domain with JPSS data products**

**CIMSS Task Leader: Anthony Wimmers**

**CIMSS Support Scientists: Christopher Velden, Jordan Gerth**

**NOAA Collaborators: Bill Ward, Kennard Kasper, Xiwu Zhan**

**Budget: \$106,000**

### **NOAA Long Term Goals:**

- Weather-Ready Nation
- Healthy Oceans
- Resilient Coastal Communities and Economies





### **NOAA Strategic Goals:**

- Serve society's needs for weather and water
- Understand climate variability and change to enhance society's ability to plan and respond
- Support the nation's commerce with information for safe, efficient and environmentally sound transportation
- Provide critical support for the NOAA mission

### **CIMSS Research Themes:**

- Satellite Meteorology Research and Applications
- Satellite Sensors and Techniques
- Environmental Models and Data Assimilation
- Education and Outreach

### **Objective**

To produce an enhanced, state-of-the-art visualization (morphed animation) of total precipitable water (TPW) that incorporates JPSS retrievals to ensure the product's viability far into the future, delivered over AWIPS, and ready to be incorporated as a major enhancement to NOAA's operational capabilities.

### **Project Overview**

Precipitable water is a quasi-conservative satellite-retrieved quantity that is uniquely suited for observation with advection from model winds over several hours. We can exploit this behavior of precipitable water to take retrievals from polar-orbiting satellites and combine them into a natural, fluid, high temporal-resolution representation of global total-column water vapor. A prior algorithm ('MIMIC-TPW version 1') used this approach to produce accurate, over-ocean visualization of TPW at hourly intervals. That product has been valuable for OCONUS stakeholders forecasting tropical weather, atmospheric rivers and aerosol transport. However, for expediency, the algorithm utilized only TPW retrievals from SSMI/SSMIS sources, and this limited the product to using older retrieval methods and left the product highly vulnerable to future data outages.

The current project replaces the previous version of MIMIC-TPW, and primarily uses TPW retrievals from ATMS and AMSU/MHS sounders from existing platforms. It uses the latest MIRS retrieval system, and also uses entirely new code for rapid processing and more robust trajectory calculations. New algorithm development is also directed toward compatibility with NOAA's current operational Blended TPW product, so that a succeeding iteration of work can more easily leverage from the two systems.

### **Milestones with Summary of Accomplishments and Findings**

The past twelve months have been directed toward extending the visualization options for the MIMIC-TPW2 product, examining areas of weakness, developing a prototype multilayer product, and presenting project results to a diverse (and growing) audience. The major milestones from this past year are as follows:

#### ***Extending MIMIC-TPW2 to RealEarth***

To move beyond the functionality of the MIMIC-TPW2 website, we added MIMIC-TPW2 to the SSEC RealEarth service. This enables interactive display options with Google Earth navigation, as well as semitransparent overlays with other model fields and satellite products. An especially effective image combination is MIMIC-TPW2 with GOES-16 longwave infrared, in order to



show the mesoscale TPW thresholds for vigorous convection (Figure 81). This also clearly displays water vapor transport-driven Chinook winds, indicated by stationary cirrus downslope clouds; latent energy sources for tropical cyclones; and the offsets between upper-troposphere cloud boundaries and near-surface moisture boundaries.

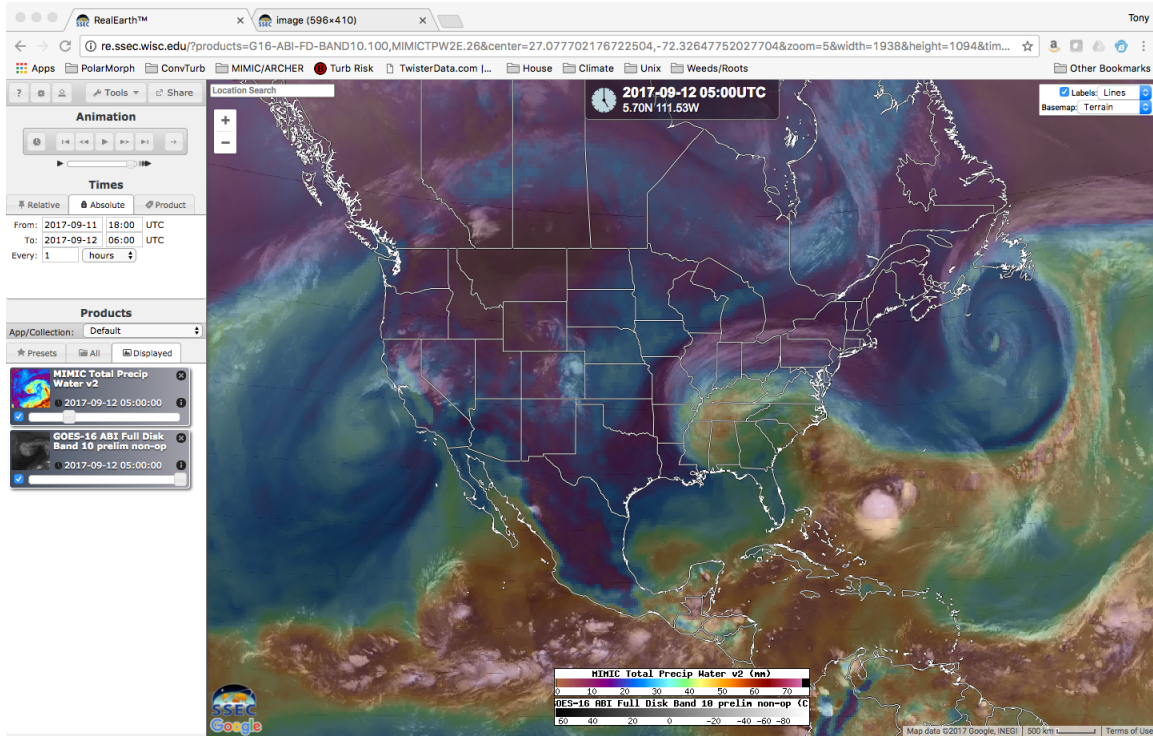

Figure 81. Screenshot of the RealEarth website with MIMIC-TPW2 and GOES-16 infrared window layers.

### **Examining Areas of Product Weakness**

We have noticed that coastal artifacts are a major source of error over land, and we have come to the conclusion that this is largely because the standard total-column wind estimate is not well suited to situations of high levels of stationary moisture trapped under a marine inversion. This is largely addressed by a multilayer treatment of precipitable water, but will be investigated further in a follow-up JPSS project.

### **Developing a Prototype Multilayer Product**

We have worked toward multilevel functionality of the MIMIC-TPW2 product to address user interest and explore future compatibility with the CIRA Blended TPW product. Specifically, we have set up a network channel to use spare disk space on a separate server in order to prevent purchasing some rather expensive disk drives for the existing server. Also, we have reconfigured the GFS retrievals and trajectory calculation code to loop through several designated layers (300-500 hPa, 500-700 hPa, 700-850 hPa and 850 hPa – Sfc) rather than one layer. This was more complicated than anticipated because of the added (vertical) dimension that required accommodation and troubleshooting in the code.

We have completed the multi-level trajectory calculation to support image morphing (Figure 82). This can now compute motions at four levels in real time. It bears noting here that this is not a redundant development compared to the CIRA multi-layer product. Unlike the CIRA product, this algorithm computes timely *global* water vapor motion using a robust second-order derivative (Runge-Kutta) computation. As the figure shows, the method allows for accurate trajectories even



around Alaska and areas poleward, which is unique to our system. However, this module does not apply satellite retrieval intercalibration, and does not operate at CIRA's resolution, so it will also benefit from an application to their framework in this way (and prevent a duplication of effort).

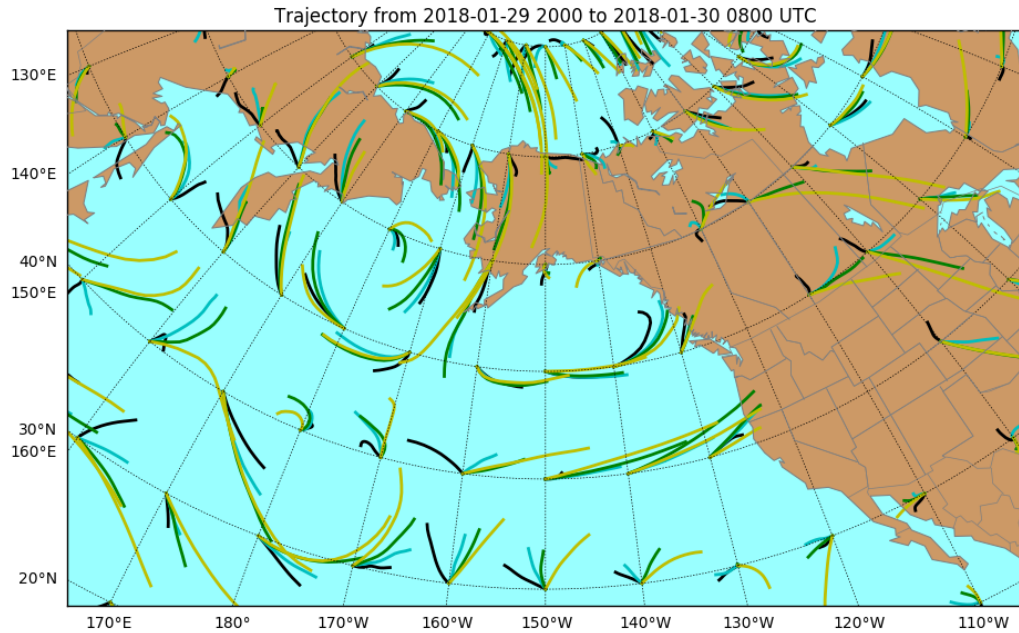

**Figure 82. Demonstration of 12-hour trajectories in the North Pacific and Alaska. The four layers are indicated by color -- Yellow: 300-500 hPa, Green: 500-700 hPa, Blue: 700-850 hPa, Black: 850 hPa - surface.**

### **Publications and Conference Reports**

We have had an above-average year of public presentations because this was the appropriate time to announce the results and encourage new users:

Wimmers, Anthony, Chris Velden, 2017: Putting the final pieces together: Seamless, global real-time imagery of total precipitable water vapor from polar-orbiting microwave satellites, NWA annual conference, Anaheim, California.

Wimmers, Anthony, 2017: MIMIC-TPW and atmospheric rivers, NWA annual conference, Anaheim, California.

Wimmers, Anthony, 2017: MIMIC-TPW and lessons learned from a lifelike verification of MIRS, JPSS annual meeting, Greenbelt, Maryland.

Wimmers, Anthony, Chris Velden, 2017: Advanced visualization of global total precipitable water with morphological compositing: A demonstration of 'MIMIC-TPW2', Keynote Address at EUMETSAT annual meeting, Rome, Italy.

Wimmers, Anthony, 2017: Satellite image products for the Central Pacific: Image morphing of tropical weather, tropical cyclone analysis and imagery enhancement of aviation hazards, Invited Lecture at the University of Hawaii – Honolulu.



### **19.3 Application of JPSS Imagers and Sounders to Tropical Cyclone Track and Intensity Forecasting**

**CIMSS Task Leader: Chris Velden**

**CIMSS Support Scientist: Derrick Herndon**

**NOAA Collaborator: Mark DeMaria**

**Budget: \$95,000**

#### **NOAA Long Term Goals:**

- Weather-Ready Nation

#### **NOAA Strategic Goals:**

- Serve society's needs for weather and water
- Provide critical support for the NOAA mission

#### **CIMSS Research Themes:**

- Satellite Meteorology Research and Applications
- Satellite Sensors and Techniques

#### **Objective**

Demonstrate an innovative satellite-based consensus approach that provides superior estimates of tropical cyclone intensity.

#### **Project Overview**

The goals of this study are to 1) integrate previously successful research on developing objective methods to derive the intensity of tropical cyclones (TCs) from multi-spectral satellite sources (Leo and Geo), and 2) demonstrate an innovative satellite-based consensus approach that employs cross-method information sharing and performance analysis to weight the consensus member estimates and ultimately provide superior estimates of TC intensity. The outcome of this work will fuse TC intensity estimates derived by proven methods from ATMS, AMSU, SSMIS and GOES/GOES-R to yield improved TC intensity analyses that will benefit operational forecasts from the National Hurricane Center, the Central Pacific Hurricane Center, and the Joint Typhoon Warning Center. They will also benefit the initialization of operational hurricane forecast models such as the HWRF run at NCEP/EMC. The research community will benefit from the improved records of TC intensity through more reliable trend analyses for climate change studies.

We plan to test, demonstrate and evaluate an innovative weighted consensus approach that takes advantage of the strengths of individual satellite-based approaches to estimate TC intensity, making use of statistical performance in given situations.

#### **Milestones with Summary of Accomplishments and Findings**

During this reporting period, an initial performance analysis of real-time SATCON TC intensity estimates during the 2017 hurricane season was completed. As of this reporting date, all of the final best tracks from NHC have not been completed due to the overwhelming activity and impacts of the 2017 season. Since the final best tracks will likely change the validation data used in the analysis, an updated analysis will be performed in the next reporting period. For this analysis, the working best tracks are compared to real-time SATCON estimates of Minimum Sea Level Pressure (MSLP) and Maximum Sustained Winds (MSW). The performance analysis shows that 2017 represents a new performance benchmark for the SATCON algorithm, with a MSLP RMSE of 6.1 hPa and MSW RMSE of 8.7 knots (Table 11). This performance is especially encouraging given the extreme intensities of the 2017 Atlantic hurricanes and indicates



that changes to the algorithm made over the last year are having a positive impact. The algorithm performed especially well during the rapid intensification phases of hurricanes Harvey, Jose and Maria. Figure 83 shows SATCON MSW compared to recon-aided working Best Track MSW for Maria. Both the rapid intensification and rapid weakening after landfall over Puerto Rico are captured well. Maria, however, also represents the largest error in the sample with a 30 knot too strong difference late on September 24. Interestingly, the SATCON MSLP error during this period is low, suggesting a significant deviation in the pressure-wind relationship during this time. Further analysis will be performed once the final best tracks from NHC are completed.

**Table 11. Real-time SATCON performance statistics for 2017 in the Atlantic and Eastern Pacific vs. NHC Working Best Track.**

N = 807	MSLP (hPa)	MSW (knots)
Bias	0.05	0.8
Average Error	4.9	6.9
RMSE	6.1	8.7

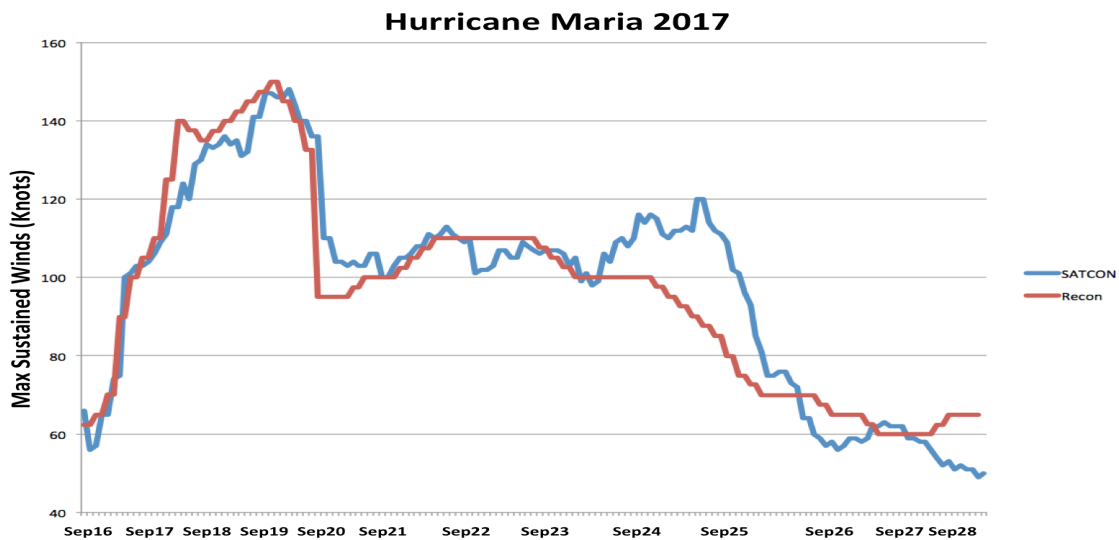

Figure 83. SATCON MSW plot compared to recon-aided best track (working) for Hurricane Maria in 2017.

#### 19.4 Further Development of the VIIRS Nighttime Lunar Reflectance-Derived Cloud Properties and the Demonstration of their use for Precipitation and Icing Applications

**CIMSS Task Leader: Andi Walther**  
**NOAA Collaborator: Andrew Heidinger**  
**Budget: \$75,000**

#### NOAA Long Term Goals:

- Climate Adaptation and Mitigation
- Weather-Ready Nation



### NOAA Strategic Goals:

- Serve society's needs for weather and water
- Understand climate variability and change to enhance society's ability to plan and respond
- Provide critical support for the NOAA mission

### CIMSS Research Themes:

- Satellite Meteorology Research and Applications
- Satellite Sensors and Techniques

### Objective

This project aims to extend the developments of VIIRS Nighttime Lunar reflectance-derived cloud products to meteorological applications

### Project Overview

The primary goal of this project is to continue advancing the use of the DNB lunar reflectance and the associated quantitative cloud property retrievals. Capitalizing on this unique and unprecedented capability, we use these cloud properties to develop proof-of-concept nocturnal precipitation and icing threat applications. This new source of nighttime information holds important value to NWP applications in high-latitude regions challenged by extensive nighttime periods, such as Alaska. These cloud properties can be incorporated into the official NOAA precipitation and icing applications in the future.

In support of this effort, we have been conducting research in the following core elements:

- Further improvements and refinements to a lunar reflectance based nighttime cloud optical retrieval scheme;
- Using lunar reflectance for improved cloud cover and cloud type retrievals at night;
- Showing the consistency of these products to the daytime equivalent;
- Exploring application of the retrieved nocturnal cloud products to precipitation and ice threat products, yielding new capabilities for these operationally important products; and
- Introducing the retrievals to operational and quasi-operational environment CSPP, NOAA framework and CLAVR-x.

### Milestones with Summary of Accomplishments and Findings

- In a former period, we have completed the development of the stand-alone VIS/IR precipitation and rain probability retrieval. We successfully **implemented** rain rate and rain probability retrieval **in CLAVR-x** software scheme.
- We **refined lunar irradiance** model according advice by Steve Miller (CIRA).
- We developed a **hybrid retrieval** merging VIIRS data with ATMS observations as an IDL-based software code. This combined visible/IR approach with Microwave measurements combines high spatial resolution of VIIRS with the more physical approach of ATMS. Image below illustrates the matching technique and gives an exemplarily visualization of rain rate from MW and from VIS/NIR.
- We have established a **webpage** <http://cimss.ssec.wisc.edu/clavrx/dncomp/> where the retrieval and results are documented. This webpage provides download section for ATBDs, user manual for CLAVR-x and near-real time section for cloud and precipitation products. We will maintain this webpage also beyond the period of this project.



## Day-Night consistency of rain rate

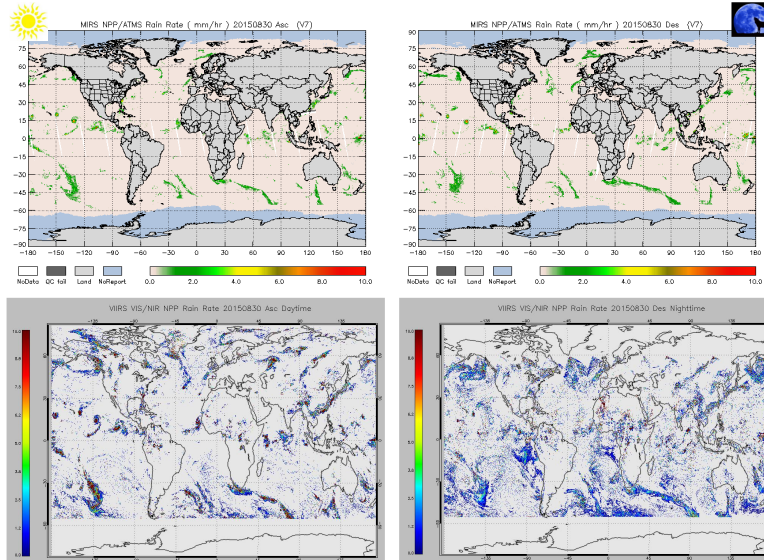

Rain rate estimates from VIS/NIR approach are largely consistent to microwave-based retrievals. Thresholds for nighttime seems to be

Figure 84. Illustration of precipitation retrieval output.

### Publications and Conference Reports

Andi Walther has presented the advances of the combined rainrate algorithm during the EUMETSAT conference in Rome, Italy in October 2017.

**19.5 CIMSS Support to In Pursuit of the Shadows: VIIRS Day/Night Band Research Enabling Scientific Advances and Expanded Operational Awareness of the Nocturnal Environment for 2017-2018**  
**CIMSS Task Leader: William Straka III**  
**NOAA Collaborator: Dan Lindsey (NOAA/NESDIS/STAR/RAMMB)**  
**Budget: \$25,000**

#### NOAA Long Term Goals:

- Weather-Ready Nation

#### NOAA Strategic Goals:

- Serve society's needs for weather and water
- Support the nation's commerce with information for safe, efficient and environmentally sound transportation
- Provide critical support for the NOAA mission

#### CIMSS Research Themes:

- Satellite Meteorology Research and Applications
- Satellite Sensors and Techniques



## Objective

The overarching goal of this project is to integrate ‘low-light visible thinking’ into the minds of the operational forecaster, providing familiarity with the new technology, and a new empowerment to forecasters as they contend with longstanding challenges of nocturnal environmental characterization.

## Project Overview

This research spans essential DNB tool development, novel user applications, instrument stewardship, and foundational research. Key components of this research at CIMSS are listed below:

1. *DNB Applications*

CIMSS will provide the DNB imagery, along with the information on the location of the imagery to aid in the explorations of new nocturnal applications, focusing on events outside of the CONUS and Alaska regions. These include disaster monitoring, (anthropogenic light changes), Cryospheric Applications (snow cover, sea ice), visibility hazards (fog, fires/smoke, dust, ash), and tropical cyclones (exposed low-level circulation)

2. *Sensor Performance & Preparation for J1*

Participation in ongoing Cal/Val Team discussions, Technical Interchange Meetings, test/evaluate potential software solutions, and support studies concerning DNB data quality on J1 and beyond.

3. *Scientific Exploration Studies*

We propose to expand the horizons of science by researching the information content present the DNB nightglow observations. This work will include the analysis and interpretation of gravity waves occurring globally as observed via specially scaled DNB nightglow imagery during the new-moon phase. We will also continue the search for widespread ‘milky sea’ marine bioluminescent events via strategic monitoring of historically active locations in Southwest Asia and Indonesia.

## Milestones with Summary of Accomplishments and Findings

The year of 2017 provided continued examples and real world applications for the Day Night Band and interactions with stakeholders. In June 2017, dry thunderstorms sparked a quick spreading wildfire near the Pedrógão Grande community of Portugal, which is about 200 kilometers (125 miles) northeast of Lisbon, resulting in at least 62 fatalities, most of whom were caught in their cars during the evacuation of the community. S-NPP overflew Portugal at 0204am UTC (~3:04am local time) on Sunday morning, roughly 3 hours after the evacuation, and caught the extraordinary fires, which are shown below in Figure 85.

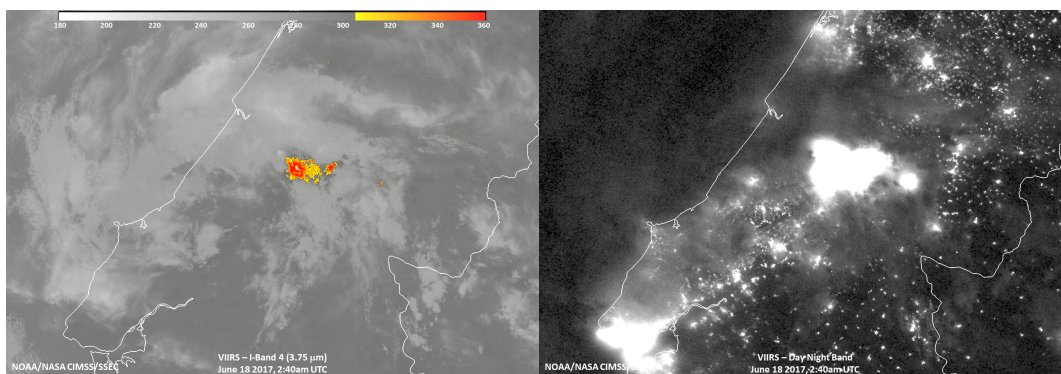

**Figure 85.** DNB and I04 satellite images from SNPP of the wildfires in Portugal. Image is from SNPP, from 18 June 2017 and ~0240 UTC.





This event provided the first in a series of interactions with EUMETSAT’s Training group, which posted a short blog article regarding the event ([https://www.eumetsat.int/website/home/Images/ImageLibrary/DAT\\_3524803.html](https://www.eumetsat.int/website/home/Images/ImageLibrary/DAT_3524803.html)). A few weeks later, a massive section of ice split off from Antarctica’s Larsen C ice shelf, and was first observed using the Day Night Band by Project MIDAS, a UK-based Antarctic research project. This opportunity provided another opportunity for both scientific and public outreach ([https://www.eumetsat.int/website/home/Images/ImageLibrary/DAT\\_3560396.html](https://www.eumetsat.int/website/home/Images/ImageLibrary/DAT_3560396.html), <http://www.jpss.noaa.gov/news.html?96>). In each case, the scientists at CIMSS interacted with others in crafting stories for the public to create awareness about significant events.

Beginning with Hurricane Harvey in mid-August 2017, a series of major hurricanes started impacting the United States. Initially, imagery was provided to the JPSS Program and NOAA Communications as part of documenting significant events. Several images provided were used on national and international media, informing the public of the impacts from these massive storms. When Hurricane Irma caused massive, long lasting, power outages Florida, JPSS Program began providing annotated imagery, such as Figure 86, to emergency response stakeholders such as FEMA, Department of Energy and US Army North in support of their response to various hurricanes.

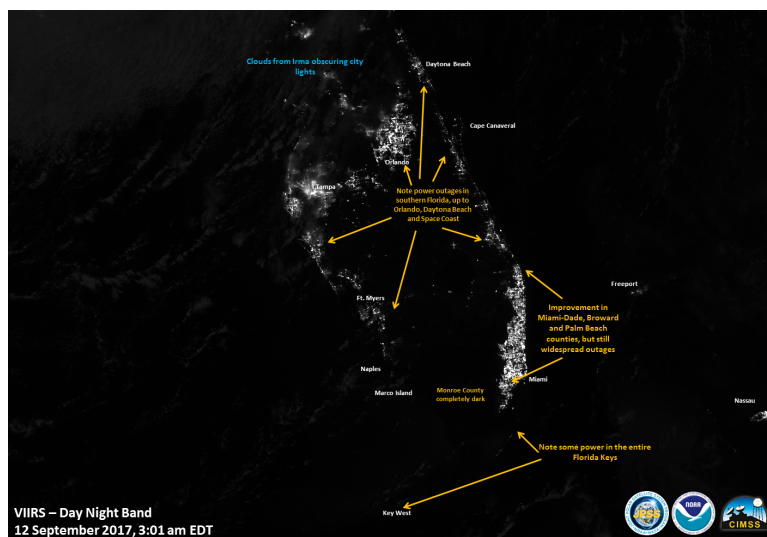

**Figure 86.** Example of annotated imagery from 12 September 2017 provided to emergency response stakeholders.

In the aftermath of Hurricane Maria, which devastated the island of Puerto Rico, this effort continued through December. Interactions with CIRA and other groups, such as SPoRT, were developed, validating and improving provided imagery.

In addition to the response to hurricanes, continued observations of mesospheric gravity waves continued, along with interactions with scientists at Hampton University who model mesospheric phenomena.

Finally, as part of the preparation for JPSS-1, CIRA and CIMSS have been participating in discussions surrounding J1 underlap issue as well as participating in the calibration and validation of the DNB after launch. In addition, CIRA and CIMSS have been exploring the usage of having two VIIRS imagers 50 minutes apart. Several examples, including a case of potential



bioluminescence (currently under investigation), have showed the usefulness of a dual-satellite configuration, even at night when the moon is not out.

### **Publications and Conference Reports**

Miller, S. D; Straka, W. C. III; Yue, J.; Seaman, C. J.; Xu, S.; Elvidge, C.D.; Hoffmann, L; Azeem, I. The Dark Side of Hurricane Matthew: Unique Perspectives from the VIIRS Day/Night Band, Bulletin of the American Meteorological Society (BAMS), 2018 (In progress).

Straka, W. C. III; Miller, S. D; Seaman, C. J.; Lindsey, D.T, Torres, J;. and Stevens, E. Usage of the VIIRS Day Night Band As an Operational Tool. Annual Symposium on Future Operational Environmental Satellite Systems, 13th, Seattle, WA, 23-27 January 2017. American Meteorological Society.

Lai, C., J. Yue; J. Xu; W. Straka III; S. D. Miller; X. Liu, 2017: Suomi NPP VIIRS/DNB imagery of nightglow gravity waves from various sources over China. Advances in Space Research, 59(8), 1951-1961, doi.org/10.1016/j.asr.2017.01.041, Manuscript Number: ASR-D-16-00683R1; Section: EM -Earth Magnetosphere/Upper Atmosphere.

Hillger, D., T. Kopp, C. J. Seaman, S. D. Miller, D. Lindsey, E. Stevens, J. Solbrig, W. Straka III, M. Kreller, A. Kuciauskas, and A. Terborg, 2016: User Validation of VIIRS Satellite Imagery. Remote Sensing 2016, Volume 8, Issue 1, doi:10.3390/rs8010011.

NOAA Booth talk – AMS 2017

## **20. GeoNetCast Americas System Development and Users' Support**

**CIMSS Task Leader: Allen Huang**

**CIMSS Support Scientists: Liam Gumley and Jerrold Robaidek**

**NOAA Collaborator: Mitch Goldberg**

**Budget: \$25,000**

### **NOAA Long Term Goals:**

- Climate Adaptation and Mitigation
- Weather-Ready Nation

### **NOAA Strategic Goals**

- Serve society's needs for weather and water
- Understand climate variability and change to enhance society's ability to plan and respond
- Support the nation's commerce with information for safe, efficient and environmentally sound transportation
- Provide critical support for the NOAA mission

### **CIMSS Research Themes:**

- Satellite Meteorology Research and Applications
- Education and Outreach

### **Objective**

Investigate the complementary role of GeoNetCast.



## Project Overview

GEONETCast Americas is the Western Hemisphere component of GEONETCast, a near real time, global network of satellite-based data dissemination systems designed to distribute space-based, air-borne and in situ data, metadata and products to diverse communities.

The task will include the investigation of the complementary role of GeoNetCast with NOAA real-time DB network including system development, distribution latency, distribution contents, users engagement and training. One GeoNetCast system will be acquired to demonstrate the real-time system functionality and benefit.

## Milestones with Summary of Accomplishments and Findings

For GEONETCast system (Figure 87) acquisition and installation, we have completed the following tasks:

- Leveraged the existing old antenna and pointed it to Intelsat 21, which is located at 58 degrees west;
- Purchased and installed the feed/LNB and demodulator;
- Acquired an ingestor/computer;
- Purchased the Fazzt software (ingest software for GEONETCast);
- Configured Novra demodulator; and
- Conducting system checkout, test, and verification.

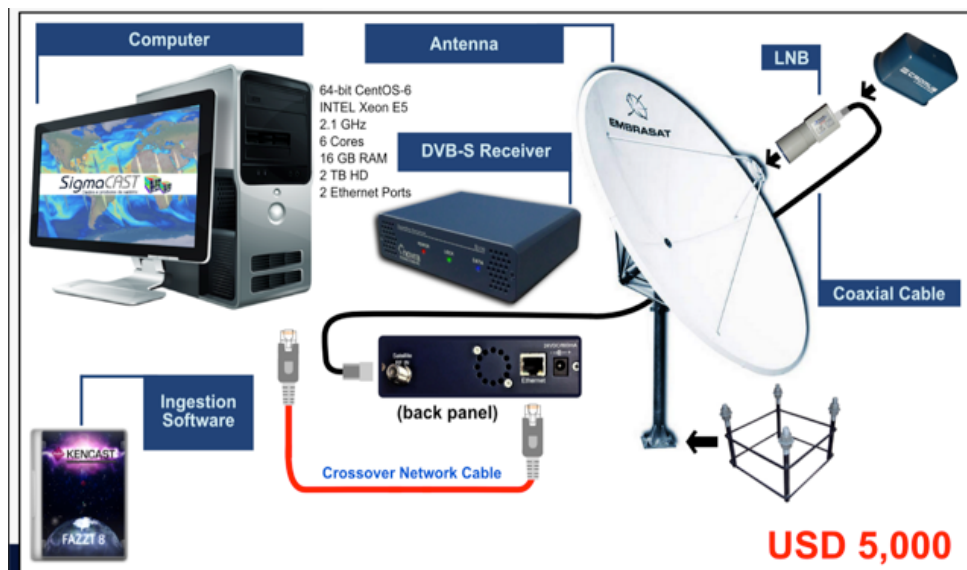

Figure 87. Schematic diagram of a typical GEONETCast-Americas station required to receive GEONETCast data/products.

## References

GEONETCast-Americas

<http://www.geonetcastamericas.noaa.gov/>

GEONETCast-Americas Product Catalog - <http://geonetcastamericas.noaa.gov/pubs/section-1/GEONETCast-Americas%20Product%20Catalog%20-%20V20152110.pdf>



## **21. CIMSS Support to the Development of a Community Satellite Processing Package (CSPP) for SuomiNPP/JPSS Real Time Regional Applications for 2017**

### **21.1 CSPP Level 2 Software Enhancement and Support**

**CIMSS Task Leader: Liam Gumley**

**CIMSS Support Scientists: Kathy Strabala, Jessica Braun, Nick Bearson, Geoff Cureton, James Davies, Scott Mindock, Graeme Martin, Ray Garcia**

**NOAA Collaborator: Mitch Goldberg**

**Budget: \$200,000**

#### **NOAA Long Term Goals:**

- Weather-Ready Nation

#### **NOAA Strategic Goals:**

- Serve society's needs for weather and water
- Provide critical support for the NOAA mission

#### **CIMSS Research Themes:**

- Satellite Meteorology Research and Applications
- Satellite Sensors and Techniques

#### **Objective**

To continue to support and update existing capabilities and add new capabilities of the Community Satellite Processing Package (CSPP) for imager and sounder data received via direct broadcast from polar orbiting satellites including primary satellite Suomi NPP, but also the NOAA-18/19, Metop-A/B, and Terra/Aqua satellites. A particular focus is the release of NOAA-developed algorithms and software for creating products from these satellites.

#### **Project Overview**

The Community Satellite Processing Package (CSPP) supports the Direct Broadcast (DB) meteorological and environmental satellite community through the packaging and distribution of open source science software. CSPP supports DB users of both polar orbiting and geostationary satellite data processing and regional real-time applications through distribution of free open source software, and through training in local product applications.

#### **Milestones with Summary of Accomplishments and Findings**

##### ***March 14, 2018*** ([CSPP S-NPP VIIRS Flood Detection Software Version 1.0](#))

First release of the NOAA S-NPP VIIRS I-Band resolution Flood Detection Software developed by Sanmei Li and Donglian Sun at George Mason University, Fairfax, Virginia. This CSPP release (CSPP\_FLOOD\_1\_0) provides VIIRS Flood Detection Software 1.0, adapted and tested for operation in a real-time direct broadcast environment. The software contains binary executable files and supporting static data files, as well as input and output files for verification of a successful installation. The CSPP VIIRS Flood Detection software is designed for global automatic flood detection using Suomi-NPP VIIRS Sensor Data Record (SDR) inputs, as well as the VIIRS Cloud Mask Environmental Data Record (EDR) if it is available. The software can be successfully executed under the following conditions:

- Day time datasets. The software will process all data within a pass where the Solar Zenith Angle is less than 85 degrees.



- Datasets with maximum latitude less than 85°N/85°S and an average latitude of the aggregated granules less than 75°N/75°S.
- When using an Area of Interest (AOI) file, the subset boundaries fall within the overpass data coverage.

**February 8, 2018** ([CSPP Microwave Integrated Retrieval System \(MIRS\) Software Version 2.0.2](#))

In response to the CSPP release of ADL Block 2.0 SDR software (CSPP Version 3.0), new MIRS bias correction files were created for S-NPP ATMS SDR inputs. A patch was designed to update the CSPP MIRS Version 2.0 software. The patch includes these changes:

- Command line option `--block=` added to accommodate new bias correction for CSPP Block 2 (version 3.0) S-NPP ATMS SDRs
- Swath pre-aggregation now uses the `--onefile` option to the "nagg" utility, which ensures contiguous pass length output files.
- Ensures that environmental variable "F\_UFMTENDIAN" is unset to ensure proper reading of MIRS accompanying data files.

**January 24, 2018** ([CSPP Polar2Grid Reprojection Software Version 2.2](#))

The CSPP Polar2Grid Software was created to enable Polar Orbiter Satellite Instrument users (for example, VIIRS, AVHRR and MODIS), including the US National Weather Service (NWS), the capability to easily create high quality reprojected imagery. NOAA JPSS has funded this effort to create an open-source, modular application system in support of direct broadcast users. This bundled solution automates tools for converting satellite data including Suomi-NPP and NOAA20 VIIRS into a variety of output formats, including GeoTIFFs, AWIPS compatible NetCDF files, NinJo forecasting workstation compatible GeoTIFF images, as well as binary and HDF5. In addition to traditional visible, infrared and microwave imagery, the software provides the capability to easily create sharpened true color and sharpened false color images. New features in Version 2.2 include:

- Support for both S-NPP and NOAA20 VIIRS Sensor Data Records (SDRs).
- A new AWIPS NetCDF "scmi" writer has been added that provides a more efficient way of creating full resolution reprojected images.
- Support for CSPP NOAA/STAR Advanced Clear-Sky Processor for Oceans (ACSPO) sea surface temperature products.
- New grid definitions for 300m, 750m and 1km AWIPS SCMI tiled sectors LCC, Polar, Mercator, and Pacific.
- Support for the CSPP NOAA/STAR Clouds from AVHRR Extended (CLAVR-x) products.
- VIIRS Day/Night Band nighttime enhancement option (`hncc_dnb`), following the algorithm developed by Stephan Zinke of EUMETSAT.

**October 31, 2017** ([CSPP NOAA VIIRS Active Fire Software Version 1.0](#))

This CSPP release provides the NOAA STAR S-NPP Data Exploration (NDE) Active Fire operational version adapted and tested for execution in a real-time direct broadcast environment. The NOAA JPSS Active Fires Team is led by Ivan Csiszar at the NOAA NESDIS Center for Satellite Applications and Research (STAR), where this software was originally developed. The software contains binary executable files, wrapper scripts and supporting static data files. A separate test data package can be downloaded for verifying a successful installation. It is the NOAA operational version ported for application to direct broadcast inputs; it replaces the active fire software that is distributed as part of the CSPP EDR software suite; and it currently produces



output at M-Band resolution, but will be updated in the near future to work with I-Band inputs. Two output products types are produced per granule at M-Band spatial resolution.

1) netCDF4 product file containing these Key Parameters:

- A fire mask that includes the confidence of fire at that pixel (%);
- Location of the active fire in terms of granule line/element and latitude/longitude;
- Band 13 brightness temperature of fire pixel (K);
- Band 15 brightness temperature of fire pixel (K);
- Fire radiative power (MW).

2) ASCII Text File containing the following information:

- Latitude of fire pixel (degrees);
- Longitude of fire pixel (degrees);
- M-Band 13 brightness temperature of fire pixel (K);
- Along-scan fire pixel resolution (km);
- Along-track fire pixel resolution (km);
- Fire detection confidence (%);
- Fire radiative power (MW).

#### **April 27, 2017** ([CSPP Polar2Grid Reprojection Software Version 2.1](#))

The CSPP Polar2Grid Software was created to enable Polar Orbiter Satellite Instrument users (for example, VIIRS, AVHRR and MODIS), including the US National Weather Service (NWS), the capability to easily create high quality reprojected imagery. NOAA JPSS has funded this effort to create an open-source, modular application system in support of direct broadcast users. This bundled solution automates tools for converting satellite data including Suomi-NPP VIIRS into a variety of output formats, including GeoTIFFs, AWIPS compatible NetCDF files, NinJo forecasting workstation compatible GeoTIFF images, as well as binary and HDF5.

In addition to traditional visible, infrared and microwave imagery, the software provides the capability to easily create sharpened true color and sharpened false color images. New features in Version 2.1 include:

- Support for both VIIRS Sensor Data Records (SDR) and VIIRS Level 1B formatted files.
- Support for the AMSR-2 microwave instrument onboard the GCOM-W1 satellite.
- Support for CSPP NOAA/STAR Microwave Integrated Retrieval System (MIRS) products.
- Added the capability to overlay borders, coastlines and grids to a Polar2Grid GeoTIFF file (add\_coastlines.sh script).
- Added the capability to add a color table to a Polar2Grid GeoTIFF file (add\_colormap.sh script).
- Added the ability to output float GeoTIFFs.
- Improved Polar2Grid documentation.

CIMSS/SSEC took delivery of a new version of the NUCAPS software system from NOAA in the form of a Delivered Algorithm Package (DAP) and adapted it to work in DB mode using both SNPP and JPSS-1 NSR and FSR input data. This delivery to CIMSS/SSEC was done in a new mode where NESDIS installs, builds and tests the software on a server at SSEC, and then hands off the delivered package to SSEC for integration and testing in the CSPP environment. The CSPP version of NUCAPS is running in DB operations at SSEC and will be released to the DB community soon.

CIMSS/SSEC took delivery of new versions of the GCOM-W1 AMSR2 Level 1 and GAASP software systems from NOAA and is now working on adapting these packages for integration, testing, and release in the CSPP environment.



CIMSS/SSEC is working with NOAA to deliver the VIIRS SuperDAP software system to SSEC in order for it to be evaluated for feasibility as a CSPP release package. At the time of writing, NOAA was still completing the installation, build, and test process on a server at SSEC.

CIMSS/SSEC took delivery of a new version of the NOAA ACSPO SST software system in the form of a DAP, and is now working on adapting the package for integration, testing, and release in the CSPP environment.

CIMSS/SSEC took delivery of a new version of the NOAA IASI NUCAPS software system in the form of a DAP, and is now working on adapting the package for integration, testing, and release in the CSPP environment.

### **Publications and Conference Reports**

The CSPP LEO team attended the 21st International TOVS Study Conference (ITSC) in Darmstadt, Germany from Nov 29 – Dec 5, 2017. One invited talk and five posters on CSPP were presented during the conference.

### **21.2 DB Real Time Network Operations, Monitoring, and Processing**

**CIMSS Task Leader: Liam Gumley**

**CIMSS Support Scientists: Kathy Strabala, Jessica Braun**

**NOAA Collaborator: Mitch Goldberg**

**Budget: \$60,000**

#### **NOAA Long Term Goals:**

- Weather-Ready Nation

#### **NOAA Strategic Goals:**

- Serve society's needs for weather and water
- Provide critical support for the NOAA mission

#### **CIMSS Research Themes:**

- Satellite Meteorology Research and Applications
- Satellite Sensors and Techniques

### **Objective**

NOAA has funded the deployment of a network of direct readout antennas across the Pacific, North America, and the Caribbean. Data from these antennas, and from other antennas who partner with NOAA, are used for real time applications including NWP assimilation of infrared and microwave sounder data at NOAA/NCEP, and creation of a range of sensor and geophysical products for real time applications. This task supports the continued operation and monitoring of the direct readout antenna network and support the maintenance of real-time processing capability for SNPP, JPSS-1, Metop-A, Metop-B, NOAA-18, NOAA-19, and GCOM-W1.

### **Project Overview**

NOAA/JPSS has funded a network of polar satellite receiving stations in North America and the Pacific. The goal is to deliver advanced infrared sounder (CrIS, IASI) and microwave sounder (ATMS) data to NOAA/NWS/NCEP with low latency for NWP data assimilation. CIMSS/SSEC at UW-Madison operates the antennas, acquires Level 0 data, and processes it centrally. Sounder



data in BUFR format are delivered to EUMETSAT and are distributed on EUMETCAST via a pilot service as part of worldwide DBNet. NOAA DB antennas for Honolulu, Madison, Miami, Mayaguez, and Guam are owned and operated by CIMSS/SSEC on behalf of NOAA. NOAA DB antennas for Fairbanks and Monterey are owned and operated by UAF and NWS, respectively. Partner DB antennas are owned and operated by other groups: Corvallis (OSU), New York (CCNY), and Hampton (HU).

The suite of products created from each pass includes:

- BUFR files from ATMS, CrIS, IASI, AMSU, MHS, HIRS, and AIRS destined for NOAA NCEP (in NOAA BUFR formats);
- BUFR files from ATMS, CrIS, IASI, AMSU, MHS, HIRS, and AIRS destined for EUMETSAT EARS (in NOAA BUFR formats for ATMS and CrIS, and EUMETSAT BUFR formats for others)
- CSPP geophysical products from NOAA operational algorithms including NUCAPS, MIRS, CLAVR-x, and ACSPO; and
- Imagery for delivery to AWIPS from imager channels; imager RGB composites; imager geophysical products; infrared and microwave sounder products.

### **Milestones with Summary of Accomplishments and Findings**

The NOAA DB Real Time Network ran reliably in operational mode during the reporting period. Advanced sounder Level 1B data in BUFR format were reliably delivered to NOAA/NWS/NCEP on a daily basis from the 10 antennas in the network. The only significant outages were a result of the Atlantic Hurricane season knocking out electrical power to the Mayaguez antenna for several months. Due to the efforts of the staff onsite at URP-Mayaguez, diesel generator power was used to power the antenna systems during daylight hours from Mon-Fri, thus allowing some data to be still be acquired and processed at the Mayaguez antenna site. 24x7 power was restored to the Mayaguez site on Feb 20, 2018.

The NOAA DB network started providing ATMS, CrIS, and IASI data in AAPP BUFR format to EUMETSAT starting in May 2017 for dissemination via EUMETCAST as a pilot service. This is done under the terms of an agreement between NOAA and EUMETSAT.

The NOAA DB network started providing ATMS, CrIS, and IASI data in AAPP BUFR format to NOAA for worldwide delivery on GTS starting in Dec 2017.

The antennas in Honolulu, Madison, Miami, Mayaguez, and Guam were all updated to support NOAA-20 reception during the reporting period.

CIMSS/SSEC started creating NUCAPS retrievals from all stations in the DB network to support the NOAA Hazardous Weather Testbed project in spring 2018. NUCAPS retrievals are produced with less than 30-minute latency and are converted to AWIPS2 compatible format. They are posted on the SSEC FTP site for project partners to download.

The local Direct Broadcast Processing System (DBPS) was updated at the Guam, Honolulu, and Miami antenna sites (Madison is the development system and is therefore always up to date). The Mayaguez site will be updated shortly.

Imagery and products for local users at NOAA antenna sites were created reliably and with low latency during the reporting period. AWIPS2 imagery was used by the local NWS weather forecast offices at Guam and Honolulu, and by multiple WFOs in CONUS.





## **Publications and Conference Reports**

Liam Gumley attended the EUMETSAT conference in Rome, Italy from October 2-6, 2017, and gave an oral presentation on the status and capabilities of the NOAA DB Real Time Network.

### **21.3 Enhancement of CSPP Polar2Grid Software for Real-Time Imagery delivery to the National Weather Service**

**CIMSS Task Leader: Kathleen Strabala**

**CIMSS Support Scientist: David Hoes**

**NOAA Collaborator: Mitch Goldberg**

**Budget: \$30,000**

#### **NOAA Long Term Goals:**

- Weather-Ready Nation

#### **NOAA Strategic Goals:**

- Serve society's needs for weather and water
- Support the nation's commerce with information for safe, efficient and environmentally sound transportation
- Provide critical support for the NOAA mission

#### **CIMSS Research Themes:**

- Satellite Meteorology Research and Applications
- Satellite Sensors and Techniques
- Education and Outreach

#### **Objective**

The objective for this work is to expand and enhance support for polar orbiter satellite data and products delivered to the National Weather Service (NWS) from locally acquired data in real-time for operational use through the Community Satellite Processing Package (CSPP) Polar2Grid software.

#### **Project Overview**

The aim of the Community Satellite Processing Package (CSPP) is to facilitate the use of Direct Broadcast (DB) polar orbiter satellite data by global environmental decision makers. Polar2Grid (P2G) is part of the CSPP software suite designed to make it easy for users to make high quality reprojected satellite product images. The target user group is the US National Weather Service. Polar2Grid is the software that enables delivery of S-NPP and NOAA20 near-real-time products to NWS Forecast Offices and Regional Centers. Polar2Grid allows conversion from swath formats to AWIPS projection grids and formats for display at the NWS in near-real-time. Polar2Grid is used by all of the groups delivering near-real-time data to the NWS, including CIMSS/SSEC, GINA/UAF, Puerto Rico, Guam and SPORT/MSFC.

#### **Milestones with Summary of Accomplishments and Findings**

Polar2Grid Version 2.2 was prepared for official release as part of the CSPP software suite in January 2018. This version includes:

- Support for NOAA20 SDRs including full resolution true color imagery in AWIPS;



- Addition of “SCMI” writer that allows full resolution tiled support for all products in AWIPS. This tiling is an efficient way for creating, transferring and displaying products in new versions of the AWIPS II client;
- Added support for CSPP NOAA Advanced Clear-Sky Processor for Oceans (ACSP0) Sea Surface Temperatures derived from S-NPP VIIRS, Aqua and Terra MODIS, and NOAA18 and NOAA19 AVHRR Imagers; and
- Added support for the CSPP NOAA Clouds from AVHRR Extended (CLAVRx) retrievals from S-NPP VIIRS, Aqua and Terra MODIS, and NOAA18 and NOAA19 AVHRR Imagers.

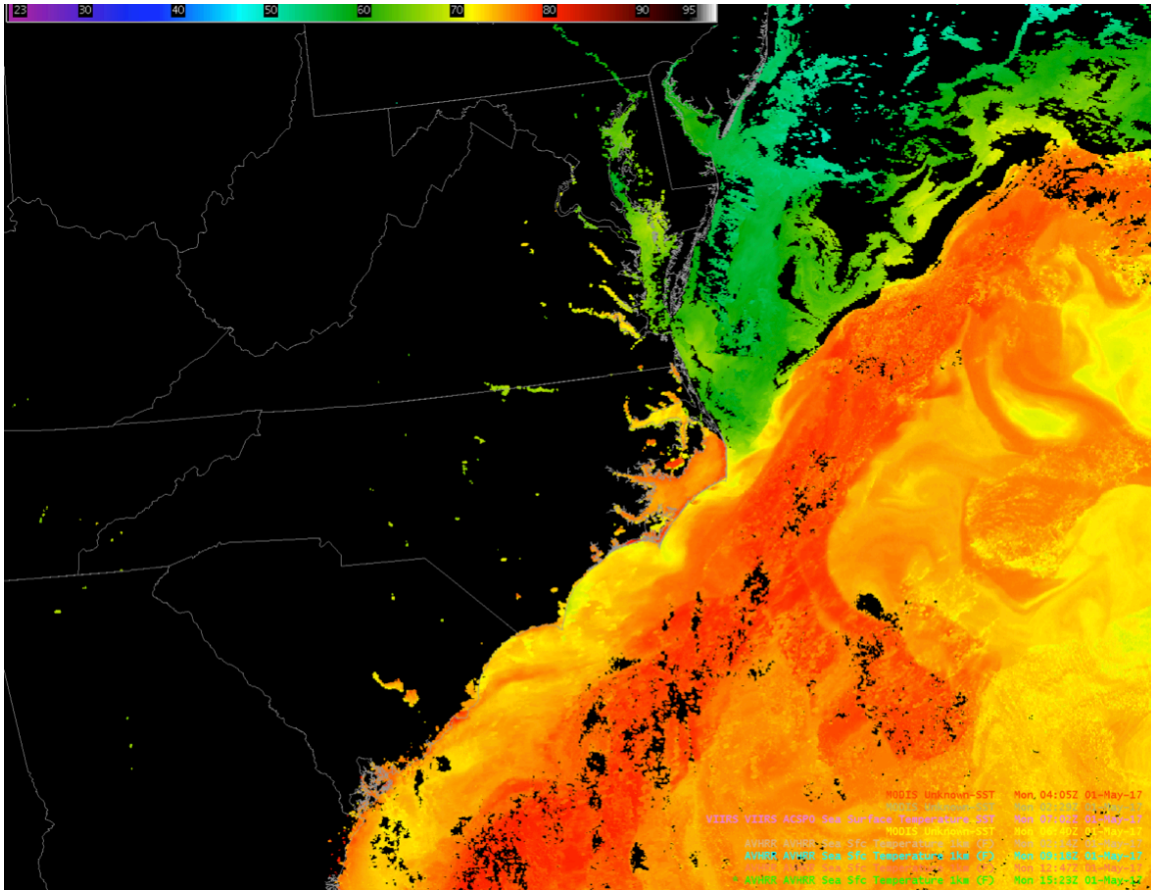

Figure 88. Composite Sea Surface Temperature ACSP0 retrieval image as displayed in AWIPS. The composite consists of 8 different VIIRS, MODIS and AVHRR overpasses acquired and processed using the CSPP Polar2Grid software at Hampton University during one 12 hour period.

### Publications and Conference Reports

David Hoese and Kathleen Strabala: “Polar2Grid – Reprojecting Satellite Data Made Easy.”  
Poster presentation at the 2018 AMS 98th Annual Meeting, Austin, Texas, 9 January 2018.

David Hoese and Kathleen Strabala: “Polar2Grid – Reprojecting Satellite Data Made Easy.”  
Poster presentation at the 2017 EUMETSAT Meteorological Satellite Conference, Rome, Italy, 2-6 October 2017.

David Hoese and Kathleen Strabala: “Polar2Grid – Reprojecting Satellite Data Made Easy.”  
Poster presentation at the 2017 CSPP/IMAPP Users’ Group Meeting, Madison, Wisconsin, 27-29 July 2017.



## **21.4 Maintenance/Enhancements to RealEarth and ISEE/JPSS App Completion**

**CIMSS Task Leader: Sam Batzli**

**CIMSS Support Scientists: Dave Parker, Russ Dingle, Nick Bearson, Tommy Jasmin**

**NOAA Collaborators: Mitch Goldberg; Jeff Key**

**Budget: \$30,000**

### **NOAA Long Term Goals:**

- Weather-Ready Nation
- Healthy Oceans
- Resilient Coastal Communities and Economies

### **NOAA Strategic Goals:**

- Serve society's needs for weather and water
- Support the nation's commerce with information for safe, efficient and environmentally sound transportation
- Provide critical support for the NOAA mission

### **CIMSS Research Themes:**

- Satellite Meteorology Research and Applications
- Education and Outreach

### **Objective**

Support visualization of CSPP products and complete the ISEE/JPSS App release to iOS/Android stores with user-login syncing to ISEE-website for notifications.

### **Project Overview**

RealEarth offers a flexible visualization platform. ISEE demonstrates the importance and value of Suomi-NPP/NOAA-20 satellites to professionals and the public and facilitates social media sharing of Suomi-NPP/NOAA-20 imagery and data products. It offers a personalized platform for informal education.

### **Milestones with Summary of Accomplishments and Findings**

- **New products added to RealEarth** including MIMIC-Total Precipitable Water.
- **Completion of notification capability:** now users can define an area of interest and notification request on either their phone OR on the <https://isee.ssec.wisc.edu> website, with synchronization between the two based on login.
- **Apps Released:** both the iOS and Android versions of ISEE/JPSS are in the respective App stores. The iOS release was delayed because of new iPhone X requirements. ISEE/JPSS has passed the new tests and is now available to the public.

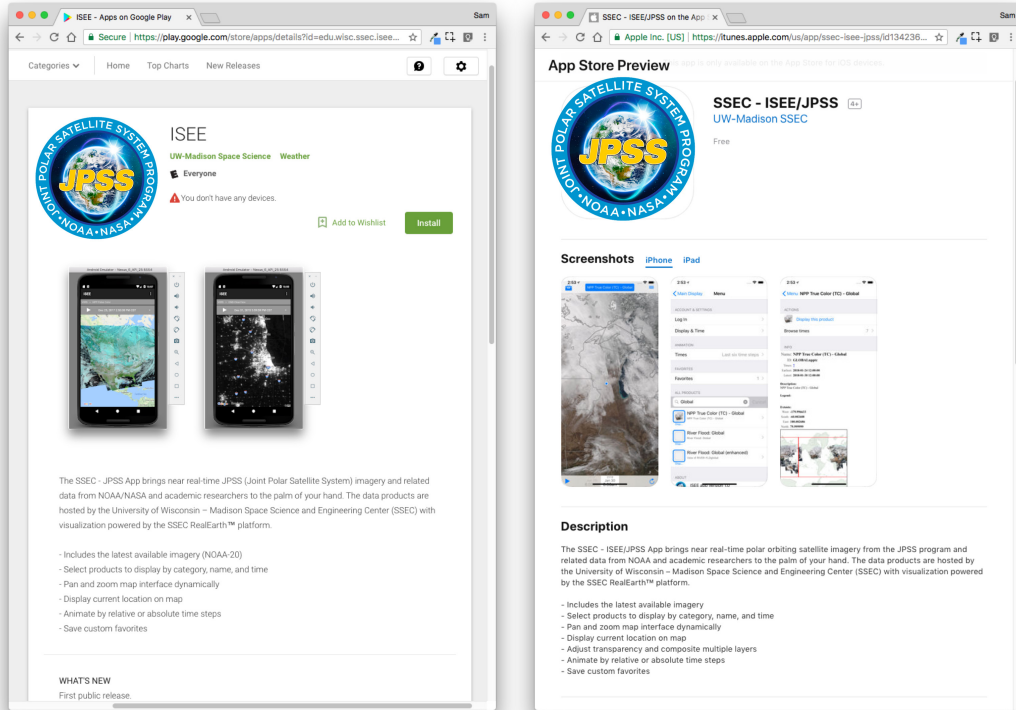

Figure 89. Left: ISEE/JRSS App in the Android Store. Right: ISEE/JRSS App in the iOS Store.

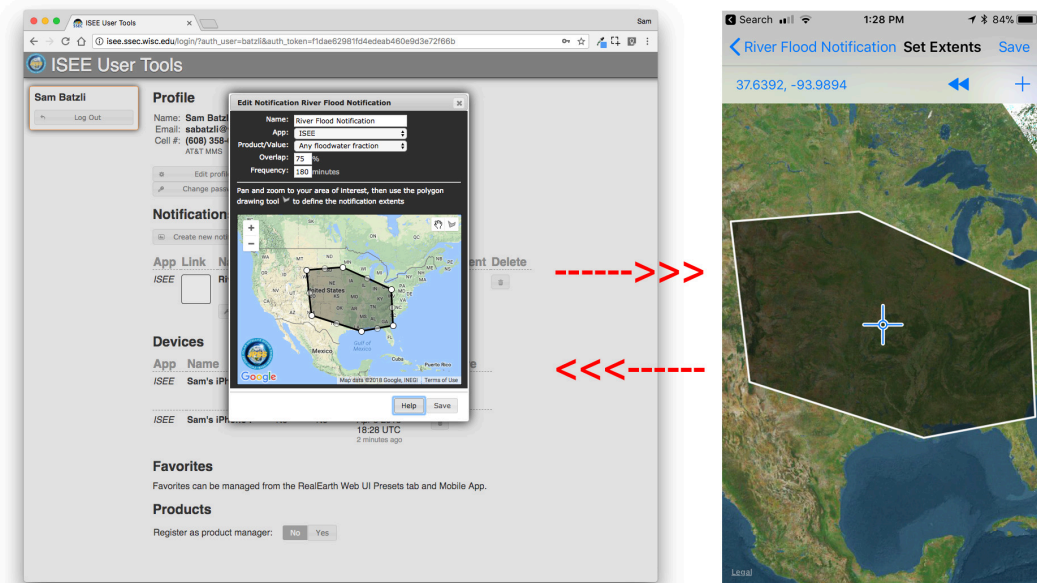

Figure 90. User-defined notifications (in this case, JPSS-detected flooding) can be synchronized between ISEE web browser and ISEE mobile App. When an event triggers a notification, the user can then share it with social media.

### Publications and Conference Reports

RealEarth: Bringing Meteorological and Atmospheric Science Imagery and Data to GIS  
RealEarth. AMS 2018, Austin, TX.



RealEarth: Visualize Your Data. Poster. Pecora 20, November 2017, Sioux Falls, SD.

## **21.5 Maintenance and Enhancements to the River Ice and Flood Products**

**CIMSS Task Leader: Jay Hoffman**

**CIMSS Support Scientists: David Santek, Russell Dengel**

**Budget:\$20,000**

### **NOAA Long Term Goals:**

- Weather-Ready Nation

### **CIMSS Research Themes:**

- Satellite Meteorology Research and Applications
- Satellite Sensors and Techniques

### **Objective**

Evaluation and maintenance of the routine generation of the GMU flood and CCNY ice products at CIMSS.

### **Project Overview**

CIMSS hosts a flood product developed at George Mason University (GMU) and a river ice product developed at City College of New York (CCNY), both product algorithms are derived from VIIRS. The GMU product provides an estimate of flooding water fractions, regions of ice, cloud, snow cover, and shadows. The CCNY algorithm produces an enhanced river ice mapping product with river ice location, extent, and concentration. Products are generated with direct broadcast VIIRS data in near real-time and sent to AWIPS and for those without access to AWIPS - SSEC's Real-Earth Web Map Service.

The success of the product has sparked interest from several river forecast centers (APRFC, NERFC, MBRFC, and WGRFC) as well as FEMA. These products could be useful to other institutions that monitor river ice and flooding conditions, especially in mid- and high-latitude locations.

## **Milestones with Summary of Accomplishments and Findings**

### ***Maintenance of CCNY's River Ice Algorithm***

CIMSS is generating this product routinely and providing it to NWS River Forecast Centers (RFC). During the reporting period, CCNY delivered a product update to CIMSS. The update (version 4.0), is aimed primarily at improving the product navigation calculations and improves on the cloud and terrain shadow masks. The river ice product runs routinely at CIMSS and Geographic Network of Alaska (GINA). The CCNY river ice product is available in AWIPS and Real-Earth

### ***Maintenance of GMU's River Flood Algorithm***

The river flood product continues to run routinely at CIMSS and GINA. An example product in Real-Earth in Figure 91, showing flooding after Hurricane Harvey in Southern Texas. The product continues to be available in Real Earth and AWIPS; a dedicated ftp site was set up so that FEMA could gain low latency access to the product as well. Efforts are underway to convert the file to shapefile format, which is better suited for the emergency management community who primarily use GIS-based software.

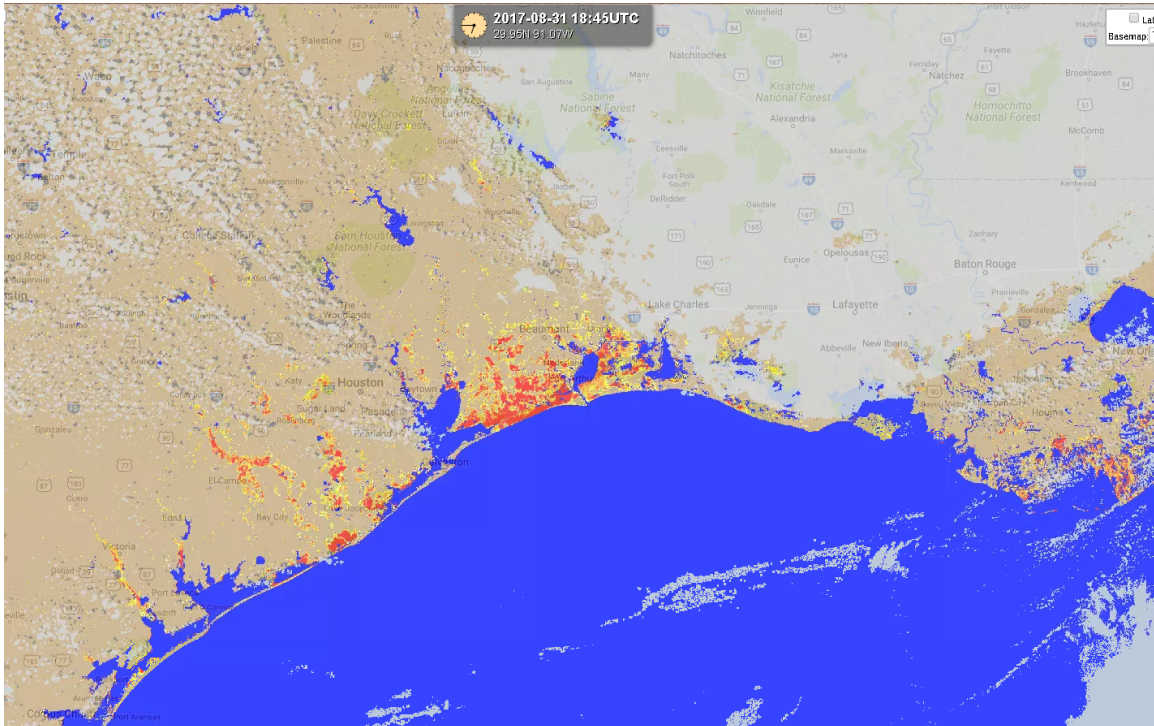

Figure 91. JPSS Flood Product example after Hurricane Harvey in Real-Earth from Aug 31, 2017.

### Publications and Conference Reports

Li, Sanmei, D. Sun, M. D. Goldberg, B. Sjoberg, D. Santek, J.P. Hoffman, M. DeWeese, P. Restrepo, S. Lindsey, E. Holloway, 2018. Automatic near real-time flood detection using Suomi-NPP/VIIRS data. *Remote Sensing of Environment* 204, 672-689.

Hoffman, J., D. Santek, S. Li, P. Romanov, 2017. Real-time Generation of Flood and River Ice and Product Derived from VIIRS Direct Broadcast Imagery. CSPP/IMAPP Users' Group Meeting. 27-29 June, 2017. Madison, WI.

### 21.6 CSPP Training and Outreach

**CIMSS Task Leader: Liam Gumley**

**CIMSS Support Scientists: Kathy Strabala, Jessica Braun**

**NOAA Collaborator: Mitch Goldberg**

**Budget: \$10,000**

#### NOAA Long Term Goals:

- Weather-Ready Nation

#### NOAA Strategic Goals:

- Serve society's needs for weather and water
- Provide critical support for the NOAA mission

#### CIMSS Research Themes:

- Satellite Meteorology Research and Applications
- Satellite Sensors and Techniques



## Objective

The objective of this task is to provide training workshops for partners in the international DB community on JPSS satellite products and applications.

## Project Overview

The Community Satellite Processing Package (CSPP) supports the Direct Broadcast (DB) meteorological and environmental satellite community through the packaging and distribution of open source science software. CSPP supports DB users of both polar orbiting and geostationary satellite data processing and regional real-time applications through distribution of free open source software, and through training in local product applications.

## Milestones with Summary of Accomplishments and Findings

CIMSS/SSEC presented a training workshop titled “Polar Orbiter Satellites in Support of Real-Time Environmental Applications” at Hampton University, VA from June 6-9, 2017. The workshop included lectures and laboratory sessions on SNPP VIIRS, CrIS, and ATMS real-time processing, software, products, and applications. On the final day students presented summaries of a short research topic they investigated during the workshop.

CIMSS/SSEC presented an overview of CSPP products and applications during a workshop titled “Training Event on Satellite Data and Product Application” in conjunction with the AOMSUC 2017 Conference in Vladivostok, Russia from October 16-21, 2017. CIMSS/SSEC presented a lecture and a laboratory session on real-time SNPP VIIRS products, applications, and software.

## 21.7 CIMSS Support for ITSC and CSPP/IMAPP Users Group Meeting

**CIMSS Task Leader: Liam Gumley**

**CIMSS Support Scientists: Kathy Strabala, Jessica Braun**

**NOAA Collaborator: Mitch Goldberg**

**Budget: \$10,000**

### NOAA Long Term Goals:

- Weather-Ready Nation

### NOAA Strategic Goals:

- Serve society’s needs for weather and water
- Provide critical support for the NOAA mission

### CIMSS Research Themes:

- Satellite Meteorology Research and Applications
- Satellite Sensors and Techniques

## Objective

The objective of this task is to provide support for user community meetings related to the CSPP LEO project.

## Project Overview

This task supported the following meetings and conferences:

- 21st International TOVS Study Conference (ITSC-21) organized by the International TOVS Working Group and held in Darmstadt, Germany from Nov 29 – Dec 5, 2017.



- ITSC-21 was organized in cooperation with, and with generous support from EUMETSAT.
- 3rd CSPP/IMAPP Users Group Meeting organized by the CIMSS/SSEC CSPP LEO team and held in Madison, Wisconsin from 27-29 June, 2017.

## **Milestones with Summary of Accomplishments and Findings**

### ***ITSC-21***

The International TOVS Working Group (ITWG) is convened as a sub-group of the [Radiation Commission](#) of the International Association of Meteorology and Atmospheric Sciences (IAMAS) and of the [Coordination Group for Meteorological Satellites](#) (CGMS). ITWG continues to organize International TOVS Study Conferences (ITSCs) which have met every 18-24 months since 1983. Through this forum, operational and research users of TIROS Operational Vertical Sounder (TOVS) data from the NOAA series of polar orbiting satellites and other atmospheric sounding data have exchanged information on methods for extracting information from these data on atmospheric temperature and moisture fields and on the impact of these data in numerical weather prediction and in climate studies. They have also prepared recommendations to guide the directions of future research and to influence relevant programs of WMO and other agencies (NASA, NESDIS, EUMETSAT). An important part of the Group's work has been to foster and participate in the generation of software to be shared throughout the community to enable use to be made of these data for operations and research. The Group also has an important education and training role.

ITSC-21 was attended by 180 participants representing 49 different organizations from 18 countries. There were 63 oral presentations and 132 posters presented during the meeting. Working Groups were formed to consider six key areas of interest to the ITWG, including:

- Radiative Transfer,
- Climate,
- Data Assimilation and Numerical Weather Prediction,
- Advanced Sounders,
- International Issues and Future Systems, and
- Products and Software.

The Working Groups reviewed recent progress in the above areas, made recommendations on key areas of concern and identified items for action. These were further reviewed in a plenary session at the end of the conference. Working Group reviews and recommendations comprise an important part of the ITSC-21 Working Group Report. The conference agenda, and all of the talks, and many of the posters can be viewed on the ITWG Web site at <http://cimss.ssec.wisc.edu/itwg/itsc/itsc21/program/>

### ***CSPP/IMAPP Users Group Meeting***

The third Community Satellite Processing Package (CSPP) and International MODIS/AIRS Processing Package (IMAPP) Users' Group Meeting was held in Madison, Wisconsin from 27-29 June 2017 at the [Fluno Center](#) on the campus of the University of Wisconsin. The goal of the meeting was to bring together the worldwide community of CSPP Low Earth Orbit (LEO) and IMAPP users to discuss issues relevant to reception, processing, and applications of data acquired by direct broadcast from Suomi NPP, Terra, and Aqua. In addition, we were pleased to include the CSPP Geostationary (GEO) direct broadcast satellite community this year, including GOES-16 and Himawari-8 users. Presentations related to other satellite missions including POES,





Metop, GCOM, FY, and Meteor were also welcome. 43 oral presentations and 13 posters were presented. Topics included:

- Local usage and application of CSPP LEO and IMAPP products from VIIRS, CrIS, ATMS, MODIS, AIRS, AMSU;
- CSPP Geo product usage and applications from GOES-16 (formerly GOES-R), and Himawari-8;
- CSPP and IMAPP Level 2 software overview and updates;
- CSPP and IMAPP software technical topics, including related software packages;
- Status of current and future environmental satellite missions and sensors;
- Feedback and guidance to the CSPP and IMAPP development teams on current products and future priorities;
- Satellite data analysis and visualization applications; and
- LEO and GEO ground stations and hardware.

The conference agenda, presentations, and posters are available at <http://www.ssec.wisc.edu/meetings/cspp/2017/>

## **21.8 JPSS Science and Innovations**

**CIMSS Task Leader: Allen Huang**

**CIMSS Support Scientist: Agnes Lim**

**NOAA Collaborator: Mitch Goldberg**

**Budget: \$30,000**

### **NOAA Long Term Goals:**

- Climate Adaptation and Mitigation
- Weather-Ready Nation

### **NOAA Strategic Goals**

- Serve society's needs for weather and water
- Understand climate variability and change to enhance society's ability to plan and respond
- Support the nation's commerce with information for safe, efficient and environmentally sound transportation
- Provide critical support for the NOAA mission

### **CIMSS Research Themes:**

- Satellite Meteorology Research and Applications
- Education and Outreach

### **Objective**

- Maintenance of JPSS Analysis Facility for Instrument Impacts on Requirements (JAFIIR)
- Fusion of NOAA LEO and GEO Satellite Data for the Development of Unified Near-Real-Time NowCasting Products



## Project Overview

### ***JPSS Analysis Facility for Instrument Impacts on Requirements (JAFIIR) - Instrument Waiver Analysis and JPSS OSSE for the Impact Analysis of JPSS Sensor on NWP Model Performance***

This task involves:

- Maintenance of OSSE to refine and support JPSS series sensor configuration change impacts on NWP forecasts, and
- CrIS and VIIRS Instrument Impacts and Waiver Analysis.

### ***Fusion of NOAA LEO and GEO Satellite Data for the Development of Unified Near-Real-Time NowCasting Products***

This task involves development and demonstration a near-real-time (NRT) operational nowcasting system for NWS forecasters and DB users via asynchronous synergistic assimilation (ASA) to achieve fusion of LEO S-NPP/JPSS CrIS/ATMS and GEO GOES-16 ABI to provide dependable unified high temporal/spatial satellite nowcasting products.

### **Milestones with Summary of Accomplishments and Findings**

Continue to maintain JAFIIR in areas of instrument waiver analysis support and ready to conduct JPSS OSSE for the impact of JPSS sensor on NWP model performance, specifically for any new CrIS sensor specification variations or changes. In addition, leverage in-house support study, the initial ASA study has been conducted using AH1 as ABI proxy to demonstrate the positive impact of the high temporal water vapor and window IR radiances on wind analysis. Preliminary study result shown in Figure 92 provides significant impact of using ABI proxy where both wind speed and direction analyzed are much improved when compare with the co-located dropwindsonde.

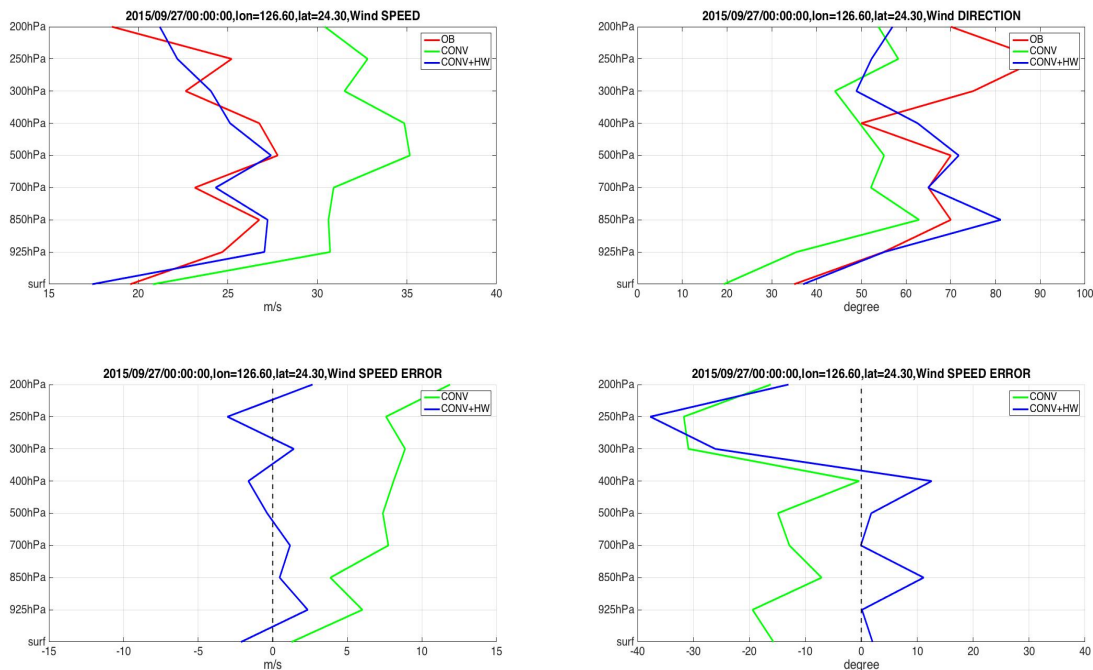

**Figure 92. Wind speed (left) and wind direction (right) comparisons between analysis with and without ABI proxy radiances and the co-located dropwindsonde observations (upper panel) and difference/error (lower panel).**



This pilot study has demonstrated the potential benefit of high temporal observations provided by S-NPP and NOAA-20 CrIS and VIIRS measurements in the analysis of retrieving high validity of four dimension of atmospheric states that are critical to nowcasting and nearcasting of severe weather events especially in the boundary layer where traditional hyperspectral or multispectral sounding have severe limitation in resolving fine vertical structure and no fully coupled wind information is available to enhance the forecasting rapid storm systems.

This study has established a creditable framework to advance the concept of harnessing low latency S-NPP/NOAA-20 constellation of CrIS/VIIRS data, where 50 minutes of orbit separation provides unique and yet to be discovered potential towards improving understanding of fine detail of thermal dynamic of rapid storm systems to advance NWS nowcasting and nearcasting priority.

#### **Publications and Conference Reports:**

Community Satellite Processing Package (CSPP) – Current Status and Future Prospect seminar at NSMC/CMA, March, 2018

## **22. CIMSS Support to the JPSS Algorithm Development Library Team for 2017**

**CIMSS Task Leader: Liam Gumley**

**CIMSS Support Scientists: Scott Mindock, Ray Garcia, Graeme Martin**

**NOAA Collaborator: Paul Meade**

**Budget: \$305,000**

#### **NOAA Long Term Goals:**

- Weather-Ready Nation

#### **NOAA Strategic Goals:**

- Serve society's needs for weather and water
- Provide critical support for the NOAA mission

#### **CIMSS Research Themes:**

- Satellite Meteorology Research and Applications
- Satellite Sensors and Techniques

#### **Objective**

SSEC/CIMSS supports the JPSS Project by providing a public release point for the Algorithm Development Library, ensuring that all users inside and outside JPSS have access to the latest version of ADL and can download, install, and run the ADL system.

#### **Project Overview**

SSEC supports the JPSS project as a member of the Algorithm Development Library (ADL)

Team by:

- Acting as the release point for ADL to the JPSS user community;
- Maintaining the ADL Website and User Forum;
- Providing user support for installing and operating ADL;
- Providing training material and courses for end users of ADL;
- Developing a Docker-based distribution of ADL;
- Developing an ingest and pre-processing capability for dynamic ancillary data in ADL;
- Verifying compatibility with RDRs from Direct Broadcast sources;



- Checking compatibility of Direct Broadcast produced SDRs with the corresponding IDPS SDRs; and
- Verifying robustness of ADL distributions before public release.

SSEC works closely with the Raytheon ADL development team and the JPSS project to ensure that ADL meets the needs of users who wish to execute and modify IDPS PRO algorithms outside the operational IDPS environment.

### **Milestones with Summary of Accomplishments and Findings**

CIMSS/SSEC continued to receive, build, and test ADL Block 2.0 versions from Raytheon including Block 2.0 versions MX1, MX2, MX3 and Block 2.1 version MX0. Accomplishments include:

- Posted the DVD contents and build instructions on the SSEC ADL website
- ADL build environment transitioned to Docker to allow easier COTS setup and testing on different Linux distributions
- Profiled VIIRS SDR geolocation code in ADL and identified performance bottlenecks due to the use of the NOVAS celestial navigation library in “high accuracy” mode.
- Modified the ADL build environment to use the NOVAS library in “reduced accuracy” mode which improved runtimes without adverse impacts on the resulting geolocation products.
- Enabled and tested the processing of both SNPP and JPSS-1 CrIS data in NSR and FSR modes.
- Optimized CrIS FSR and SDR runtimes by providing Correction Matrix Object (CMO) LUTs instead of computing CMOs on the fly.
- Added serialization of CrIS SDR processing to improve runtimes by avoiding multiple instances of CMO.
- Performed extensive analyses of SDR code runtime performance and comparisons against SDR data created at IDPS to ensure correct operation of the SDR software in ADL.

As a result of CIMSS/SSEC efforts working with the SDR algorithms in ADL, the CIMSS/SSEC team was able to process on-orbit data from JPSS-1 on the following timeline:

- JPSS-1 was launched on Nov 12, 2017
- JPSS-1 ATMS SDR data from HRD were processed on Nov 30, 2017
- JPSS-1 VIIRS SDR data from HRD were processed on Dec 15, 2017
- JPSS-1 CrIS SDR data from HRD were processed on Jan 5, 2018

### **Publications and Conference Reports**

Scott Mindock attended the JPSS Science meeting at NCWCP in College Park in August 2017.

## **23. CIMSS Ongoing Investigations in Support of the JPSS Program Office 2017**

**CIMSS Task Leader: W. Menzel**

**CIMSS Support Scientists: E. Weisz, E. Borbas**

**NOAA Collaborator: M. Goldberg**

**Budget: \$40,000**



### **NOAA Long Term Goals:**

- Climate Adaptation and Mitigation
- Weather-Ready Nation

### **NOAA Strategic Goals:**

- Serve society's needs for weather and water
- Understand climate variability and change to enhance society's ability to plan and respond
- Provide critical support for the NOAA mission

### **CIMSS Research Themes:**

- Satellite Meteorology Research and Applications
- Satellite Sensors and Techniques

### **Objective**

To demonstrate extension of the HIRS cloud and moisture data sets with IASI and CrIS measurements.

### **Project Overview**

High spectral resolution IASI and CrIS data have been spectrally averaged to resemble the HIRS broad band spectral coverage and cloud top and clear sky moisture properties are being estimated from the resulting radiances. In addition the high spectral resolution data are being investigated for opportunities to characterize the uncertainties in the cloud and moisture products derived from broad band measurements. To date VIIRS/CrIS and AVHRR/IASI records of cloud top properties (pressure and effective emissivity) compared well with those from AVHRR/IRS. In the last year we showed the same for moisture determinations (TPW and UTH).

### **Milestones with Summary of Accomplishments and Findings**

HIRS atmospheric profile algorithm retrieves vertical profiles (soundings) of temperature and moisture, total column ozone burden, integrated total column precipitable water vapor, and several atmospheric stability indices (Seemann et al. 2003 and 2008). The algorithm is based on a statistical regression. The retrievals are performed using clear sky radiances measured by HIRS over land and ocean for both day and night. The products being studied include total column moisture and three layers of moisture (high, middle, and low). The HIRS moisture retrieval algorithm consists of several procedures that include cloud detection, forward model calculation, and regression retrieval. The radiative transfer calculation of the HIRS spectral band radiances is performed using a transmittance model called RTTOV (Saunders et al., 2017).

The moisture algorithm (Level 2 processing of individual HIRS FOVs) for the HIRS data record has been implemented in much the same way as the 5-km Collection 6 MODIS (MOD06) algorithm (NASA MODIS Atmospheric Profiles ATBD, 2011). Collocated AVHRR GAC pixels within HIRS FOVs are used in the same way that MODIS 1-km pixels within 5x5-pixel regions are used for clear versus cloudy identification (PATMOS-x cloud mask, Heidinger et al 2016); both algorithms use the 15% cloud coverage threshold for generating retrievals. Atmospheric profile data from the CFSR model is used to derive HIRS moisture products analogously as NCEP GDAS (Global Data Assimilation System) data is used for MODIS moisture products. The SeeBor training database (Borbas et al. 2005) consists of 15,704 global profiles of temperature, moisture, and ozone at 101 pressure levels for clear sky. The radiative transfer calculation provides for a given temperature-moisture-ozone profile the corresponding HIRS radiances. Estimates of the HIRS instrument noise are added onto the calculated spectral band radiances.



Figure 93 and Table 12 show the comparison of MetOpA HIRS and HIRS-IASI UTH and TPW for 15 December 2012. The AVHRR cloud mask at GAC resolution was used to determine cloud free skies in the HIRS and IASI FOVs. For these MetOpA data, there is good UTH agreement everywhere and TPW agreement is found in the northern mid-latitudes and but HIRS TPW is drier than that of HIRS-IASI in the mean by 0.9 (0.7) mm in the tropics (southern mid-latitudes). But these values are well within the rms of any single TPW determination (~3 mm) against truth. In the collocated FOVs, TPW values agree within 1 mm.

Figure 94 and Table 13 show the comparison of NOAA-19 HIRS and Suomi NPP HIRS-CrIS UTH and TPW for 15 December 2012. VIIRS was used to establish a cloud mask for CrIS, as AVHRR was used for HIRS. For these N19 and SNPP data, there are a considerable number more CrIS than HIRS determinations. Again there is good UTH agreement everywhere while the HIRS TPW is drier (more moist) in the mean by 1.3 (1.4) mm in the tropics (southern mid-latitudes). The non-simultaneity of the HIRS and CrIS observations can be the cause of the greater TPW scatter. Again, these values are well within the rms of any single TPW determination (~3 mm) against truth. In the collocated FOVs, TPW values agree within 1 mm.

FOVs used for moisture determinations are predominantly clear (based on subpixel cloud masks from AVHRR GAC or VIIRS data); HIRS FOVs are found to be better than 97.5% clear while IASI and CrIS FOVs are better than 94.5% clear. HIRS FOVs are more clear (warmer so drier) than IASI and CrIS FOVs (colder so moister). However a dry HIRS bias is not found everywhere (e.g. southern mid-latitudes); differences in FOV size and VIIRS versus AVHRR GAC cloud masks are having a small effect also.

**Table 12. The distribution for 15 December 2012 of UTH and TPW mean and standard deviation determined for MetOp-A HIRS and HIRS-IASI (H-I) for measurements in the northern mid-latitudes (30 to 60N), tropics (30S to 30N), and southern mid-latitudes (60S to 30S). The number of FOVs is indicated in parentheses; note that the differences are calculated only for the FOVs viewing the same location.**

	UTH (mm)			TPW (mm)		
	HIRS	H-I	Differences (HIRS - H-I)	HIRS	H-I	Differences (HIRS - H-I)
<b>NML</b>	0.15±0.13 (8994)	0.15±0.14 (8263)	0.00±0.02 (6252)	5.5±5.2 (8994)	5.5±5.4 (8263)	-0.1±0.7 (6252)
<b>Tropics</b>	0.49±0.39 (21306)	0.48±0.37 (21971)	-0.01±0.05 (16993)	26.4±12.5 (21306)	27.3±13.0 (21971)	-1.0±1.6 (16993)
<b>SML</b>	0.33±0.23 (5475)	0.32±0.21 (5068)	0.01±0.04 (3830)	16.0±5.5 (5475)	16.7±5.5 (5068)	-0.5±1.0 (3830)

**Table 13. The distribution for 15 December 2012 afternoon of UTH and TPW mean and standard deviation determined for NOAA-19 HIRS and HIRS-CrIS (H-C) for measurements in the northern mid-latitudes (30N to 60N), tropics (30S to 30N), and southern mid-latitudes (60S to 30S). The number of FOVs is indicated in parentheses; note that the differences are calculated only for the FOVs viewing the same location.**

	UTH (mm)			TPW (mm)		
	HIRS	H-C	Differences (HIRS-H-C)	HIRS	H-C	Differences (HIRS-H-C)
<b>NML</b>	0.14±0.15 (6669)	0.15±0.13 (12267)	0.00±0.03 (5390)	6.3±6.4 (6669)	6.6±6.1 (12267)	0.3±1.2 (5390)
<b>Tropics</b>	0.56±0.44 (21304)	0.59±0.49 (34797)	0.00±0.08 (15359)	28.4±14.4 (21304)	29.7±14.0 (34797)	0.5±2.4 (15359)
<b>SML</b>	0.36±0.27 (4761)	0.36±0.28 (9893)	0.01±0.07 (3735)	19.7±7.8 (4761)	18.3±7.1 (9893)	1.0±2.3 (3735)

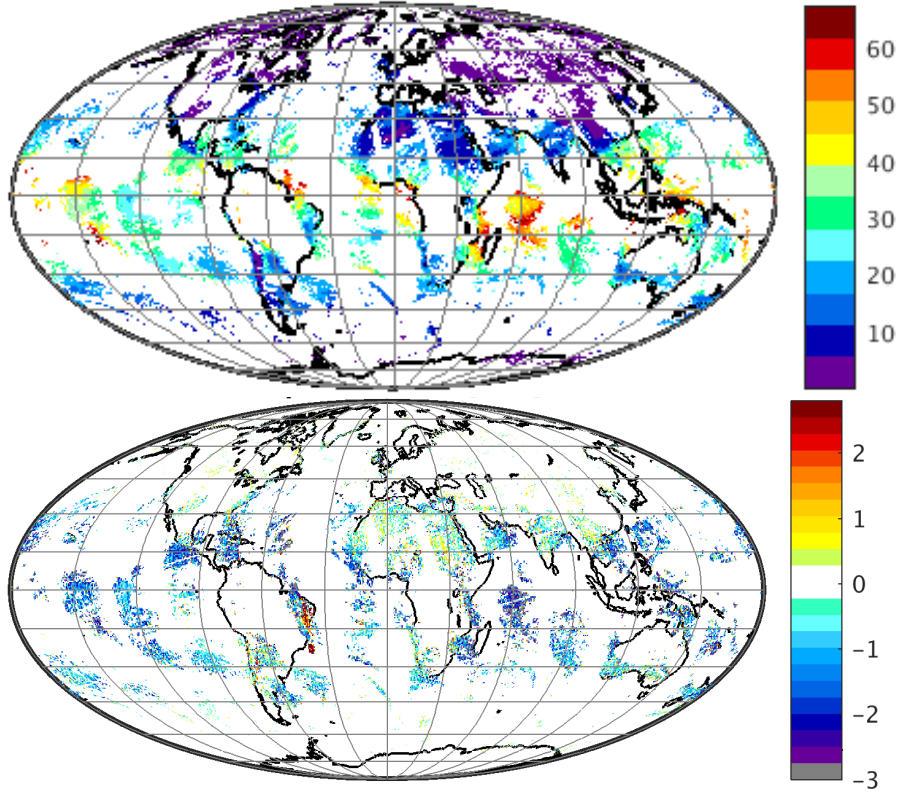

Figure 93. HIRS-IASI TPW for 15 Dec 2012 (top) and HIRS minus HIRS-IASI TPW difference (bottom).

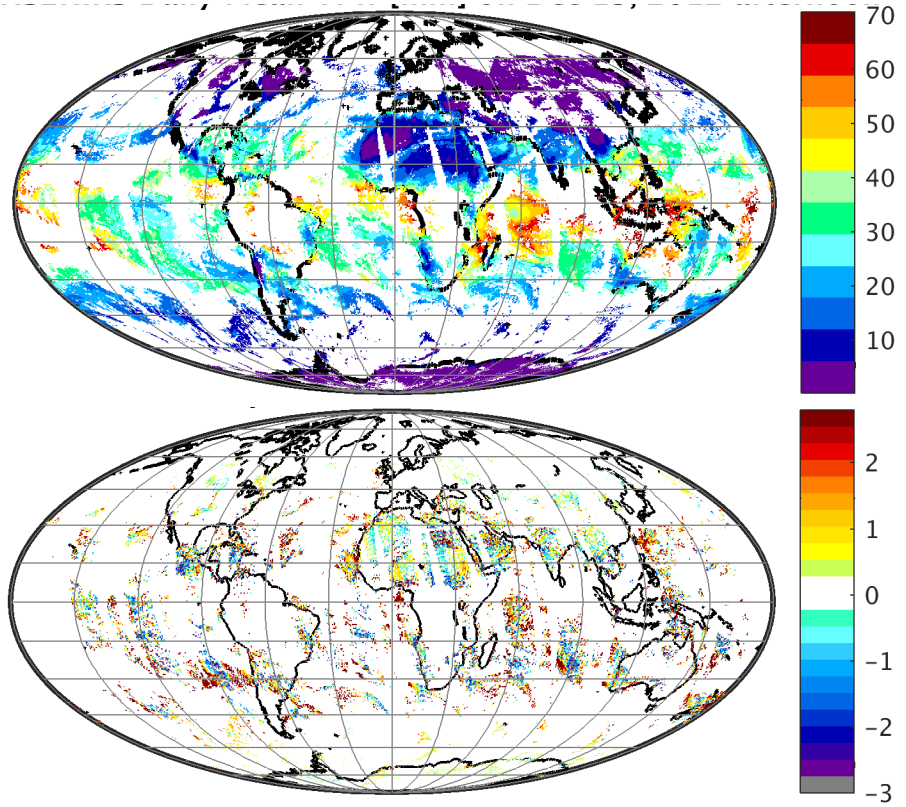

Figure 94. HIRS-CrIS TPW for 15 Dec 2012 (top) and HIRS minus HIRS-CrIS TPW difference (bottom).



Based on a global day of comparisons, we conclude that AVHRR/IASI and VIIRS/CrIS can provide continuity for the AVHRR/HIRS moisture record (TPW determinations within 1 mm), understanding that FOV size and sampling differences will cause a small adjustment in cloud detection percentages.

Creation of AVHRR/IASI and VIIRS/CrIS moisture records would extend the HIRS-like records to more than 50 years; this will offer the longest record for investigating global and hemispheric trends.

## References

Borbas, E., S. W. Seemann, H.-L. Huang, J. Li, and W. P. Menzel, 2005: Global profile training database for satellite regression retrievals with estimates of skin temperature and emissivity. Proc. of the Int. ATOVS Study Conference-XIV, Beijing, China, 25-31 May 2005, pp763-770.

Heidinger, A. K., D. Botambekov, and A. Walther (2016), Algorithm Theoretical Basis Document. A naive Bayesian cloud mask delivered to NOAA enterprise, Version 1.2, SSEC Publication No.16.10.H2, NOAA, NESDIS, Center for Satellite Applications and Research, 2016, Madison, WI.

Saunders, R., J. Hocking, D. Rundle, P. Rayer, S. Havemann, M. Matricardi, A. Geer, L. Cristina, P. Brunel, and J. Vidot, 2017: RTTOV-12 Science and Validation Report, NWPSAF-MO-TV-41, 2017

Seemann, S. W., J. Li, W. P. Menzel, and L. E. Gumley, 2003. Operational retrieval of atmospheric temperature, moisture, and ozone from MODIS infrared radiances. *J. Appl. Meteor.*, 42, 1072-1091.

\_\_\_\_\_, Borbas, E.E., Knuteson, R.O., Stephenson, G.R., and Huang, H-L., 2008: Development of a global infrared emissivity database for application to clear sky sounding retrievals from multi-spectral satellite radiances measurements. *J. Appl. Meteorol. and Clim.* 47, 108-123

## 24. Implementation of GCOM-W1 AMSR2 Snow Products

**CIMSS Task Leader: Yong-Keun Lee**

**NOAA Collaborators: Jeffrey R. Key (NOAA) and Cezar Kongoli (CICS)**

**Budget: \$60,000**

### NOAA Long Term Goals:

- Climate Adaptation and Mitigation
- Weather-Ready Nation

### NOAA Strategic Goals:

- Serve society's needs for weather and water
- Understand climate variability and change to enhance society's ability to plan and respond
- Support the nation's commerce with information for safe, efficient and environmentally sound transportation
- Provide critical support for the NOAA mission





### **CIMSS Research Themes:**

- Satellite Meteorology Research and Applications
- Satellite Sensors and Techniques
- Environmental Models and Data Assimilation
- Education and Outreach

### **Objective**

The objectives of this project include continuous testing and validation of the snow algorithm and routine snow product generation with AMSR2 data. The selected heritage algorithms are being modified as necessary.

### **Project Overview**

Snow is one of the most dynamic hydrological variables on the Earth's surface and the cryospheric component with the largest seasonal variation in spatial extent. It also plays a key role in the global energy and water budget. Since microwave radiation is unhindered by darkness and clouds and penetrates a deeper layer of snow cover at certain frequencies, satellite passive microwave measurements have been used to detect snow cover and snow depth globally in nearly all weather conditions. The Advanced Microwave Scanning Radiometer 2 (AMSR2) instrument launched on the Japan Aerospace Exploration Agency (JAXA) Global Change Observation Mission 1st – Water "SHIZUKU" (GCOM-W1) satellite. NOAA is supporting work with AMSR2 as part of the Joint Polar Satellite System (JPSS) program.

AMSR2 cryosphere environmental data records (EDRs) include snow products: Snow Cover/Depth, and Snow Water Equivalent (SWE). Snow Cover/Depth includes a binary snow/no snow mask and the depth of snow on land. Snow Water Equivalent is the liquid equivalent depth of the snow cover.

### **Milestones with Summary of Accomplishments and Findings**

The suite of AMSR2 algorithms developed for the retrieval of snow cover and snow depth is comprised of well-established methods is now being used operationally by NOAA. The snow cover detection algorithm is based on a brightness temperature-based decision tree approach (Grody, 1991; Grody and Basist, 1996) with additional climatology tests as enhancements. The snow depth algorithm is based on a dynamic empirical approach (Kelly, 2009) blended with a routine for dry/wet snow differentiation.

Accomplishments for this project year include the statistics generation of the AMSR2 snow cover detection during the recent period by monthly, forest fraction and elevation. Figure 95 shows the comparison of the retrieved AMSR2 snow cover detection with IMS snow products between January 2015 and October 2017 with several error statistics (See Lee et al. 2015 for the errors' definitions).



## AMSR2 Snow Cover Statistics, Jan 2015 – Oct 2017

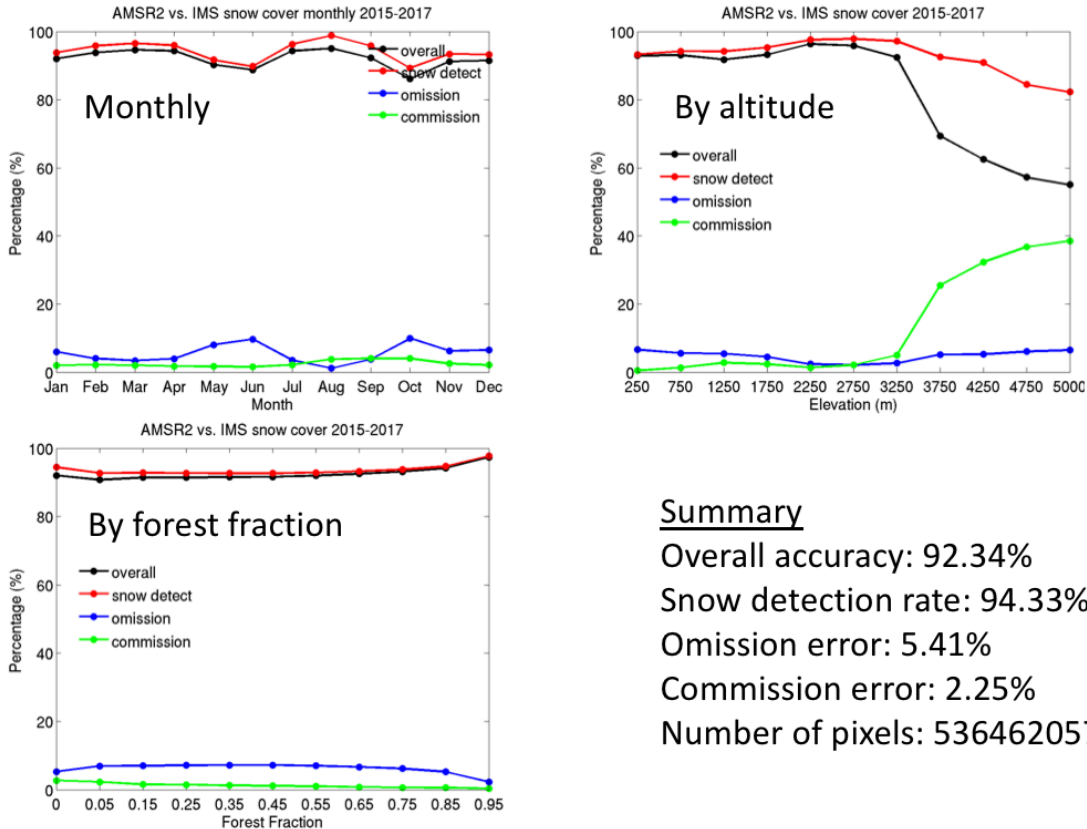

**Figure 95. Snow detection accuracy.** Overall accuracy (overall) is the number of pixels where both AMSR2 and IMS detect snow or no-snow divided by the total number, where the total number is the sum of valid AMSR2 pixel numbers for snow detection test. Snow detection rate (snow detect) is the number of pixels where both AMSR2 and IMS detect snow divided by the number of pixels where IMS detects snow. Omission error (omission) is the number of pixels where AMSR2 misses snow divided by the total number. Commission error (commission) is the number of pixels where AMSR2 incorrectly detects snow divided by the total number.

### Publications and Conference Reports

Lee, Y.-K., C. Kongoli, and J. R. Key, 2017: “NOAA AMSR2 Snow products”, NOAA-JAXA AMSR2 Technical Exchange Meeting, Nov. Tokyo, Japan.

### References

Grody, N. C., (1991), Classification of snow cover and precipitation using the special sensor microwave imager, *J. Geophys. Res.*, 96 (D4), pp 7423-7435.

Grody, N. C., and A. N. Basist, (1996), Global identification of snowcover using SSM/I measurements, *IEEE Trans. Geosci. Remote Sens.*, 34 (1), pp 237-249.

Kelly, R., (2009), The AMSR-E snow depth algorithm: description and initial results, *J. Remote Sensing Soc. Japan*, 29 (1), pp 307-317.

Lee, Y.-K., C. Kongoli, and J. R. Key, (2015), An in-depth evaluation of heritage algorithms for snow cover and snow depth using AMSR-E and AMSR2 measurements, *J. Atmos. Oceanic Technol.*, 32, 2319-2336. doi: 10.1175/JTECH-D-15-0100.1.



## **25. Support CIMSS JPSS and AWIPS II OCONUS Satellite Liaison**

**CIMSS Task Leader: Jordan Gerth**

**NOAA Collaborators: Bill Ward and Eric Lau, National Weather Service Pacific Region Headquarters; and Nathan Eckstein, National Weather Service Alaska Region**

**Budget: \$200,000**

### **NOAA Long Term Goals:**

- Weather-Ready Nation

### **NOAA Strategic Goals:**

- Serve society's needs for weather and water
- Provide critical support for the NOAA mission

### **CIMSS Research Themes:**

- Satellite Meteorology Research and Applications
- Education and Outreach

### **Objective**

This project funds a dedicated scientist that improves NOAA's research to operations (R2O) mechanisms and maximizes the operational value of geostationary and polar-orbiting satellite data and research products at National Weather Service (NWS) forecast offices in the Outside CONTiguous United States (OCONUS), particularly Alaska and Hawaii. The scientist serves in a wide array of relevant and related roles: as a satellite liaison, user advocate, R2O consultant, software engineer, subject-matter expert, trainer of operational meteorologists, and atmospheric and oceanic sciences researcher.

### **Project Overview**

The Outside CONTiguous United States (OCONUS) satellite scientist serves four primary functions beyond his capacity as a satellite meteorologist and remote sensing scientist for National Weather Service (NWS) forecast offices in the states of Alaska and Hawaii, and the territories of Guam, American Samoa, and Puerto Rico.

- First, the scientist is a software developer and technical consultant, focusing on the Advanced Weather Interactive Processing System (AWIPS) and the related technical infrastructure, including networking, data flow, and antenna systems, to assure satellite imagery and products are consistently and reliability supplied to the field and meeting the needs of operational meteorologists in the OCONUS and throughout the United States.
- Second, the scientist is a coordinator of regional satellite proving ground and related activities, including the visiting scientist program in NWS Pacific Region. The proving ground introduces new derived satellite products and satellite imagery interpretation techniques to the relevant field offices.
- Third, the scientist is a liaison for meteorologists and office management in NWS Pacific Region and Alaska Region to assist in the development and delivery of training and addressing specific questions about the capabilities of current and future meteorological satellites, particularly the Geostationary Operational Environmental Satellite R-Series (GOES-R, now GOES-16/17) and Joint Polar Satellite System (JPSS, now NOAA-20).
- Fourth, the scientist is a consultant to the Chair of the NWS Operational Advisory Team (NOAT), and coordinates activities with the satellite program leadership as a user



advocate, namely recommending and implementing satellite proving ground and training initiatives.

### **Milestones with Summary of Accomplishments and Findings**

The scientist funded under this project:

- Ensures that meteorologists in the OCONUS achieve optimal understanding on the use of satellite imagery and products for the best possible daily operations;
- Conducts scientific investigations and serving as the coordinator for demonstrating JPSS-related science products in NWS Pacific Region and Alaska Region operations;
- Integrates GOES-R/GOES-17, Himawari-8/9, NPP, JPSS/NOAA-20, and GCOM imagery and science products into the AWIPS; and
- Acts as a technical coordinator and AWIPS developer for GOES-R and JPSS proving ground partners.

The major milestones and related accomplishments between 1 April 2017 and 31 March 2018 are indicative of the value of this project. Specifically, the scientist:

- Conducted site visits to NWS forecast offices in Anchorage, Alaska, Fairbanks, Alaska, Juneau, Alaska, Honolulu, Hawaii, Pago Pago, American Samoa, and Barrigada, Guam, and data collection offices in Lihue, Hawaii, and Hilo, Hawaii;
- Worked with the Community Satellite Processing Package (CSPP) package development team to establish output formats that are compatible with AWIPS, and conducted related testing and configuration in AWIPS;
- Configured AWIPS at the NWS Pacific Region Headquarters (PRH), Honolulu Forecast Office (HFO), American Samoa field office, and Guam field office to ingest and display Himawari-8/9 and other satellite imagery and derived products at the highest spatial, spectral, and temporal resolution available, with Eric Lau;
- Served as a member of the Satellite Enhancement Team (SET) to ensure satisfactory “day one” visualization of imagery and derived products from GOES-R/GOES-17 and JPSS/NOAA-20;
- Participated on the Satellite Training Advisory Team (STAT) with weekly training teleconferences and planning meetings to recommend and track the development of foundational course content and subsequent applications-centric training materials related to GOES-R/GOES-17 and JPSS/NOAA-20 for all NWS meteorologists;
- Began coordinating nationwide NWS training activities related to JPSS, serving as a subject-matter expert to review some foundational course modules;
- Hosted a visiting scientist, Anthony Wimmers, at HFO to introduce improved techniques for identifying severe turbulence with imagery from Himawari-8/9;
- Led and contributed to JPSS training events, such as short courses, at annual meetings of the American Meteorological Society and National Weather Association;
- Assisted with planning and executing the 2017 NOAA Satellite Conference and 2018 JPSS Alaska Summit;
- Maintained the L/X-band antenna at Honolulu Community College and assured that imagery and products from the antenna system were available to staff at NWS PRH and HFO;
- Maintained the L/X-band antenna at the Guam forecast office and assured that imagery and products from the antenna system were available to the local office staff;
- Consulted on best practices to maintain the L/X-band antenna at the NOAA Inouye Regional Center in Pearl Harbor, Hawaii;
- Participated in JPSS reviews of proving ground and risk reductions projects and proposals; and



- Supported the JPSS initiatives and other satellite liaisons in NWS Alaska Region.

The scientist attended the following meetings during the award period:

- NOAA Satellite Conference (New York City, New York);
- American Meteorological Society Summer Community Meeting (Madison, Wisconsin);
- National Weather Association Annual Meeting (Garden Grove, California); and
- American Meteorological Society Annual Meeting (Austin, Texas).

## **Publications and Conference Reports**

### ***Publications***

Cintineo, J.L., M.J. Pavolonis, J.M. Sieglaff, D.T. Lindsey, L. Cronce, J. Gerth, B. Rodenkirch, J. Brunner, and C. Gravelle, 2018: The NOAA/CIMSS ProbSevere Model: Incorporation of Total Lightning and Validation. *Wea. Forecasting*, **33**, 331–345, <https://doi.org/10.1175/WAF-D-17-0099.1>

Wimmers, A., S. Griffin, J. Gerth, S. Bachmeier, and S. Lindstrom, 2018: Observations of Gravity Waves with High-Pass Filtering in the New Generation of Geostationary Imagers and Their Relation to Aircraft Turbulence. *Wea. Forecasting*, **33**, 139–144, <https://doi.org/10.1175/WAF-D-17-0080.1>

### ***Conference Reports***

“New satellites, new applications, and future expectations for GOES-R and JPSS”

Jordan Gerth, corresponding author/presenter

Talk, National Weather Association Annual Meeting—State of the Science (Garden Grove, California), 18 September 2017

“How NOAA Jump-Started the 2017 Satellite Conference to Engage the Audience”

Jordan Gerth, corresponding author/presenter

Talk, American Meteorological Society Annual Meeting—27th Symposium on Education (Austin, Texas), 10 January 2018, Manuscript available

## **26. CIMSS Support to JPSS Field Terminal Segment (FTS) Tasks 2017**

**CIMSS Task Leader: Liam Gumley**

**CIMSS Support Scientists: Scott Mindock, Graeme Martin, Ray Garcia, Kathy Strabala, Jessica Braun**

**NOAA Collaborator: Mitch Goldberg**

**Budget: \$500,000**

### **NOAA Long Term Goals:**

- Weather-Ready Nation

### **NOAA Strategic Goals:**

- Serve society’s needs for weather and water
- Provide critical support for the NOAA mission



### **CIMSS Research Themes:**

- Satellite Meteorology Research and Applications
- Satellite Sensors and Techniques

### **Objective**

The goal of this project is to provide the JPSS Sensor Data Record (SDR) software to the public in the form of (a) buildable and executable binaries in the Algorithm Development Library (ADL) environment, and (b) value-added software as part of the Community Satellite Processing Package (CSPP) for easy-to-use processing of data received from SNPP and JPSS satellites in direct broadcast mode. This project also supports real-time processing of data from SNPP and JPSS-1 and provision of products to the National Weather Service.

### **Project Overview**

CIMSS/SSEC supports JPSS FTS by providing algorithm and software integration services to enable users to integrate JPSS SDR algorithms into their local processing systems through the development of user-friendly software packages. CIMSS/SSEC provides software packages, supporting ancillary data, documentation and training, end user support, and value-added products and software as part of this effort. CIMSS/SSEC acquires and processes HRD from SNPP and JPSS using its existing 2.4-meter X/L-band antenna system to track the quality of the HRD transmission and monitor the validity of the products created from the HRD broadcast. Products are delivered to the National Weather Service with low latency.

### **Milestones with Summary of Accomplishments and Findings**

The CSPP SDR software package is based on the Algorithm Development Library (ADL) software developed by Raytheon for the JPSS Project. ADL allows the operational processing algorithms for Suomi NPP to run without modification in a Linux environment. SSEC has packaged the ADL versions of the Suomi NPP and JPSS-1 algorithms so they can run from the Linux command line in real-time direct broadcast mode, but we have not changed the underlying processing software, algorithms, or data formats. The output files from the CSPP SDR processing software are identical in naming, format, and structure to the corresponding files from NOAA/NESDIS.

CSPP SDR Version 3.0 was released to the DB community on October 11, 2017. This software package supports calibration and geolocation of Sensor Data Records for the Visible Infrared Imaging Radiometer Suite (VIIRS), Advanced Technology Microwave Sounder (ATMS), and the Cross-track Infrared Sounder (CrIS) on the S-NPP and JPSS-1 Satellites. The SDR software code base has been updated to ADL Version 5.3.16 (Mx3), also known as Block 2.0, representing significant code base changes that include the use of a database for ancillary and Look-Up-Table management. Features include:

- CSPP SDR v3.0 is ready to process VIIRS, ATMS, and CrIS data from JPSS-1.
- CSPP SDR code base has been updated to Block 2.0 ADL Version 5.3.16 (Mx3).
- CrIS Normal Spectral Resolution (NSR) and Full Spectral Resolution (FSR) SDR processing is supported.
- CrIS and ATMS output yield for direct broadcast processing has improved (more granules are created for each pass) due to improved handling of incomplete granules.
- CrIS NSR processing times are shorter, due to Correction Matrix Operator (CMO) data being included with the software package as a lookup table instead of being computed at runtime.



- New dynamic ancillary and Look-Up-Table (LUT) update scripts have been created for compatibility with the database used internally by Block 2.0 ADL. These scripts are the recommended way of acquiring dynamic support data for CSPP SDR processing.
- A single script (ql\_sdr.sh) is now used to create VIIRS, CrIS and ATMS quicklook images.

CSPP SDR Version 3.0.3 was released to the DB community on December 22, 2017. This update allowed the CSPP SDR software to ingest calibration LUTs released by NESDIS after the launch of JPSS-1, that are required to process the on-orbit data from VIIRS, CrIS, and ATMS.

Extensive comparisons of the CSPP SDR Version 3.0 products against the corresponding IDPS SDR products were conducted to ensure that the HRD products are consistent with SMD products. Critical partners including EUMETSAT, the Met Office, and MeteoFrance were engaged in this process to ensure that their own real-time SDR products were consistent with global data and appropriate for low latency ingest in NWP assimilation systems.

CIMSS/SSEC ingested all required ancillary data for the VIIRS, CrIS, and ATMS SDRs and to make them available for download to users of the CSPP SDR software. End users are able to run an automated script that will check for new LUTs on the CIMSS/SSEC FTP site, and if necessary download, unpack, and install the LUTs without user intervention. CIMSS/SSEC obtained the LUTs from the JPSS FTS website and from the JPSS project for this purpose.

During the reporting period CIMSS/SSEC continued to process real-time SNPP direct broadcast data over CONUS and provided the products to National Weather Service forecast offices for display in AWIPS2. Imagery products visible and infrared single channels, true color and false color imagery, and Day/night band imagery with several enhancements. In December 2017, CIMSS/SSEC began to receive and process data from the JPSS-1 (NOAA-20) satellite. VIIRS image products are now created routinely for both SNPP and JPSS-1, converted to AWIPS2 compatible format, and delivered to NWS forecast offices. In addition, geophysical products from VIIRS, CrIS, and ATMS including cloud mask/phase/height/optical depth, aerosol loading, water vapor, temperature and moisture profiles, sea surface temperature, ocean chlorophyll, land surface temperature, wildfire locations, vegetation index, surface reflectance, and rain rate are created in near real-time and made available to CIMSS/SSEC research partners.

During the reporting period CIMSS/SSEC set up a real-time monitoring capability for the HRD transmissions from JPSS-1 and SNPP. The HRD transmissions are received by the Orbital Systems 2.4-meter X/L-band reception system at SSEC. Movies of the received signal characteristics from each pass are captured via a frame grabber attached to an Agilent E4407B spectrum analyzer in line with the down-converted 720 MHz IF output. Plots of signal strength as a function of time, elevation, and azimuth are captured from the antenna control computer for each pass. RT-STPS status logs for each pass are captured. The monitoring products for both SNPP and JPSS-1 are made available on a website at CIMSS/SSEC and were shared with the JPSS project.

CIMSS/SSEC provided timely email support to end users who rely on the CSPP SDR software including EUMETSAT, the Met Office, MeteoFrance, NRL Stennis, NRL FNMOG, SMHI, FMI, CSIR, and DWD.



## **27. CIMSS Participation in the Evaluation on the Alternative of Advanced IR and MW Sounders with CIRAS and MicroMAS-2 for Weather Forecasting through OSSE**

**CIMSS Task Leader: Jun Li**

**CIMSS Support Scientists: Zhenglong Li, Pei Wang, Agnes Lim, Jinlong Li, Frederick W Nagle**

**NOAA Collaborators: Timothy Schmit, NOAA/NESDIS/STAR, Robert Atlas, NOAA/AOML, Sid Boukabara, NOAA/NESDIS/STAR, and John Pereira/Kevin Tewey/David Hermreck, NOAA/NESDIS/OPPA**

**Budget: \$142,000**

### **NOAA Long Term Goals:**

- Weather-Ready Nation

### **NOAA Strategic Goals:**

- Serve society's needs for weather and water
- Support the nation's commerce with information for safe, efficient and environmentally sound transportation
- Provide critical support for the NOAA mission

### **CIMSS Research Themes:**

- Satellite Meteorology Research and Applications
- Satellite Sensors and Techniques
- Environmental Models and Data Assimilation

### **Objective**

The objective is to use quick regional OSSE (r-OSSE) to explore the potential of CubeSat-based microwave and infrared sounders to mitigate the data gap of CrIS and ATMS.

### **Project Overview**

The main focus on this project is for CIMSS to participate in the evaluation on the alternative of microwave (MW) and advanced Infrared (IR) sounders with Micro-sized Microwave Atmospheric Satellite-2 (MicroMAS-2) and CubeSat Infrared Atmospheric Sounder (CIRAS) for weather forecasting through quick regional Observing System Simulation Experiment (OSSE). This will be helpful in the event of a data gap of CrIS or ATMS. For this second year of funding support on this project, CIMSS OSSE team focuses on impact study of different configurations of MicroMAS-2 and CIRAS, and their potentials on mitigating the data gap of ATMS and CrIS. For FY17, under the guidance of OPPO, CIMSS OSSE team's focus is on the Earth Observing Nanosatellite-Microwave (EON-MW).

### **Milestones with Summary of Accomplishments and Findings**

#### ***Development of Simulation and Assimilation Strategy for Quick Regional OSSE***

This year's work focuses on impact study. The community Gridpoint Statistical Interpolation (GSI) system (v3.3), currently operational used by NOAA NCEP, is used to assimilate various observations for this study (Wang et al., 2013; Kleist et al., 2009; Wu et al., 2002). Since both MicroMAS-2 and CIRAS are future instruments, GSI does not have the capability to assimilate them in the current system. Both observations are converted to the observations that GSI is able to assimilate. For MicroMAS-2, an indirect way of radiance assimilation is undertaken. For example, a linear regression relationship is constructed between MicroMAS-2 brightness



temperature (Tb) and ATMS Tb with the former as predictors and latter as predictants. Since ATMS has much more channels (22) than MicroMAS-2 (12), not all ATMS channels are well predicted by MicroMAS-2. After evaluation, only 11 ATMS channels (7, 8, 9, 11, 12, 16, 18, 19, 20, 21, and 22) are well predicted, and they are converted to BUFR and assimilated directly to represent the assimilation of MicroMAS-2 radiances.

CIRAS observes radiances in shortwave infrared spectral region. No existing radiance observations around that spectral region are currently assimilated in GSI system. Synthetic sounding retrievals are performed to get the atmospheric temperature and moisture profiles from the CIRAS radiance observations. A linear regression relationship is constructed between the T/Q profiles from the High Resolution Nature Run (HRNR) and the simulated CIRAS Tb using a small percentage (5%) of the data. And the regression coefficients are applied to rest of the data. Due to various uncertainties in real world (i.e. RT model, representative error, etc), the radiance observation errors are doubled in both the training and the retrieval. Bad retrievals are thrown away with a quality control (QC) by comparison of the calculated radiances with observations. Similarly, CrIS is assimilated through sounding retrievals. Due to the coarse spectral resolution and narrower spectral coverage, CIRAS does not have the same sounding quality as CrIS. It's important to point out that a decent portion of CIRAS radiance observations are affected by NLTE, which is ignored in the CRTM forward simulation. Both CIRAS and CrIS synthetic sounding retrievals are converted to PREPBUFR, which can be directly digested into GSI.

### Flow chart of the quick R-OSSE

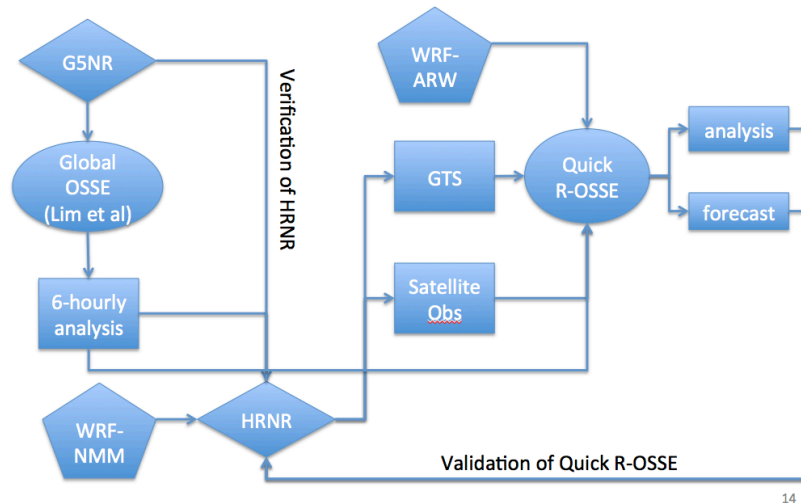

Figure 96. Flowchart of the quick R-OSSE.

Figure 96 shows the flow chart of the quick R-OSSE. The left half shows the generation of the HRNR from the global OSSE analysis. After that, synthetic observations of radiosonde and satellite observations are generated from the HRNR. For the quick R-OSSE, the WRF-ARW v3.6.1 is used to avoid identical twin NWP model problem. Compared with the WRF-NMM used for HRNR generation, the WRF-ARW has a much coarse spatial resolution (9 km), smaller coverage (450x280 grid points), and different schemes are used, including New Thompson scheme for microphysics, RRTMG for longwave radiation scheme, RRTMG for shortwave radiation scheme, Yonsei University scheme for planetary boundary layer, and Kain-Fritsch scheme for cumulus parameterization. The NAM BE is used as background error covariance, and the satellite angle and mass bias are updated each cycle. Similarly, the 6-hourly analysis from the global OSSE (Lim et al. 2017) is used as initialization and boundary conditions. The experiments



initialize at 06 UTC on May 26. After 6 hours of spin-up, three cycles of assimilation are carried out every 6 hours until 00 UTC on May 27, followed by 18 hours of forecast. The forecast is compared with the HRNR to evaluate the analysis and the forecast.

For each instrument, four experiments are conducted:

- a. The GAP, which assumes either ATMS or CrIS is lost. For this quick R-OSSE, not all existing observations are simulated and assimilated; only the conventional RAOB, AMSU-A and IASI from Metop-B (the only morning orbit that is not beyond its lifetime) are included to represent the existing capability except the SNPP/JPSS.
- b. The control run (CNTL), which includes either ATMS or CrIS to represent the existing capability.
- c. The mitigation option 1 (MO1), which replaces the ATMS or CrIS with MicroMAS-2 or CIRAS with the 1:30 pm orbit. This is the same orbit as SNPP/JPSS.
- d. The mitigation option 2 (MO2), which replaces the ATMS or CrIS with 3 MicroMAS-2 or 3 CIRAS with the 10:30 am, 1:30 pm and 4:30 pm orbits. Two more orbits are added to increase the data coverage of cubesat.

This study will investigate whether using one or 3 MicroMAS-2 or CIRAS is able to mitigate the loss of ATMS and CrIS.

### ***Impact Study on Local Severe Storm (LSS) from MicroMAS-2 and CIRAS***

Usually, a few select parameters will be used to evaluate the analysis/forecast of each experiment, such as precipitation, convective inhibition (CIN), CAPE, helicity etc for LSS. While these are important parameters for forecasting LSS, they cannot represent the whole capability of the analysis/forecast. In this study, one value is calculated to represent the overall performance of the experiment based on the four important LSS parameters (combining precipitation, LI, CAPE and Helicity) plus the thermodynamic field of the whole domain, including T/Q/U/V at 4 standard atmospheric levels (250, 500, 700 and 850 hPa). For each parameter, a normalized root mean square error (RMSE) is calculated. The normalization makes it possible to combine different parameters. The final normalized RMSE is weighted averaged using:

CAPE \* 10%

CIN \* 10%

Helicity \* 10%

Rainfall \* 20%

Thermodynamic \* 50%

The selected parameters are given large weight because of their importance in LSS forecast, especially the precipitation. All thermodynamic parameters (T/Q/U/V) are averaged together with a 50 % weight. The calculation is performed at analysis time and every 6-hour forecasts. A final normalized RMSE is calculated for each of the four experiments. Results are shown in next sections. Smaller value indicates better results.

Figure 97 shows the final normalized RMSE of the four experiments for MicroMAS-2. The ATMS is effective in reducing the normalized RMSE from 0.5028 to 0.4998. The two MOs are both able to reduce the normalized RMSE from the GAP scenario. However, single MicroMAS-2 (MO1) is not able to mitigate the GAP with a final RMSE larger (0.5013) than the CNTL. ON the other hand, the MO2 (three MicroMAS-2) is more effective than MO1 with one single MicroMAS-2. The final RMSE of 0.4966 is smaller than the CNTL, indicating the MO2 is able to mitigate the GAP in this particular LSS case.

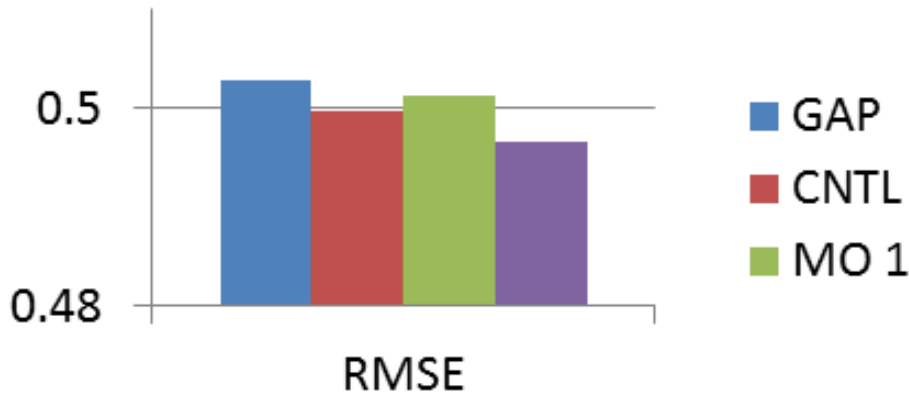

**Figure 97.** The final RMSE for the four experiments of MicroMAS-2. GAP assimilates RAOB, AMSU-A and IASI from Metop-B. CNTL assimilates everything from GAP plus ATMS. MO1 assimilates everything from GAP plus MicroMAS-2 with 1:30 pm orbit. And MO2 assimilates everything from GAP plus 3 MicroMAS-2 with 10:30 am, 1:30 pm, and 4:30 pm orbits.

Figure 98 shows the final normalized RMSE of the four experiments for CIRAS. The CrIS is effective in reducing the normalized RMSE from 0.5054 to 0.4962. Again, the two MOs are both able to reduce the normalized RMSE from the GAP scenario. While the three CIRAS (MO2) is able to further reduce the normalized RMSE from single CIRAS (MO1) and close to CrIS, it is not as good as CrIS in this particular LSS case.

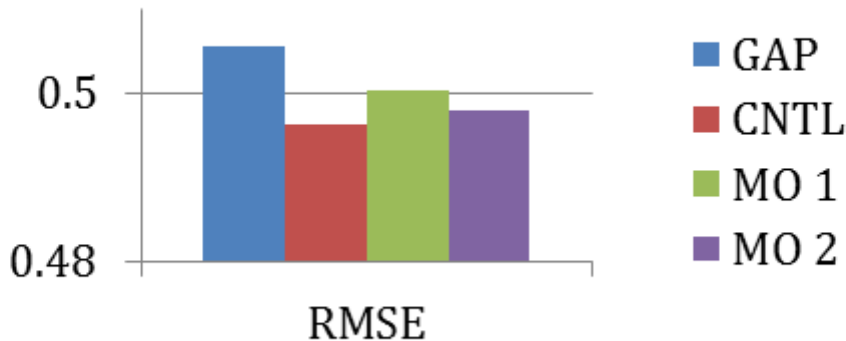

**Figure 98.** The final RMSE for the four experiments of CIRAS. GAP assimilates RAOB, AMSU-A and IASI from Metop-B. CNTL assimilates everything from GAP plus CrIS. MO1 assimilates everything from GAP plus CIRAS with 1:30 pm orbit. And MO2 assimilates everything from GAP plus 3 CIRAS with 10:30 am, 1:30 pm, and 4:30 pm orbits.

While 3 CIRAS in this particular LSS case are close to CrIS but still not as good as CrIS in this particular LSS case, the above results indicate that (a) both single MicroMAS-2 and CIRAS are able to provide additional positive impact on the LSS forecast; (b) more CubeSats with increased data coverage yield larger positive impacts; and (c) both MicroMAS-2 and CIRAS have potential to mitigate the loss of ATMS and CrIS on SNPP and JPSS, especially when there are multiple CubeSats launched into orbits.

It is important to note the limitation of this study. The results presented are through quick R-OSSE, meaning the OSSE system is not calibrated. In GAP scenario, only RAOB and Metop-B observations are included to represent the existing capability minus the SNPP. This is an underestimate of the existing capability. Also, for CIRAS, the CRTM coefficients do not have the



NLTE included. The CRTM simulation of NLTE has an error of about 1 – 1.5 K. This might result in an overestimate of CIRAS capability.

### **Preliminary Results from EON-MW Quick R-OSSE**

The Earth Observing Nanosatellite-Microwave (EON-MW), from MIT Lincoln Laboratory, is a 22-channel high-resolution microwave spectrometer that aims to mitigate the potential data gap of ATMS from SNPP and JPSS. For the OSSE study, EON-MW is put on the same orbit as ATMS on SNPP. The evaluation of EON-MW on local severe storm forecast follows the same strategy as MicroMAS-2; the EON-MW radiances are converted to ATMS radiances through linear regression. Same as ATMS, channel 15 is excluded for assimilation. Preliminary results are shown in Figure 99. Note that the control run (CNTL) has been expanded to include AMSU-A from NOAA-15, 18, 19, Aqua, MetOp-A/B, and IASI from MetOp-A/B, which is a good representative of existing capability. It shows that EON-MW has a comparable performance as ATMS on reducing the overall forecast error for this case study of local severe storm forecast.

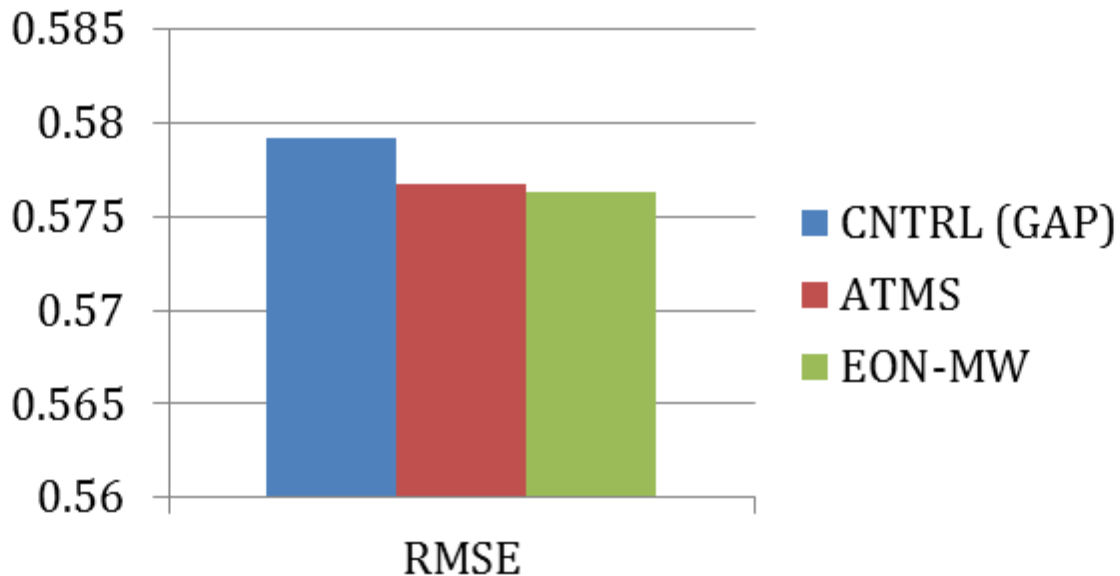

Figure 99. The final RMSE for the three experiments of EON-MW. GAP assimilates RAOB, AMSU-A from NOAA-15, 18, 19, Aqua, MetOp-A, and B, IASI from MetOp-A and B. CNTL assimilates everything from GAP plus ATMS, and CON-MW assimilates everything from GAP plus EON-MW.

### **Publications and Conference Reports**

Li, Zhenglong, Jun Li, Pei Wang, Agnes Lim, Jinlong Li, Timothy Schmit, and Robert Atlas, 2018: Value-added impact from geostationary hyperspectral infrared sounder on local severe storm forecasts – a case demonstration with quick regional OSSE, *Advances in Atmospheric Sciences*, Under Review.

Li, J., Z. Li, P. Wang, T. J. Schmit, W. Bai, and R. Atlas (2017), An efficient radiative transfer model for hyperspectral IR radiance simulation and applications under cloudy-sky conditions, *J. Geophys. Res. Atmos.*, 122, doi:10.1002/2016JD026273.

Jones, Thomas A.; Koch, Steven, and Li, Zhenglong. Assimilating synthetic hyperspectral sounder temperature and humidity retrievals to improve severe weather forecasts. *Atmospheric Research* v.186, no.1, 2017, pp9-25.



Li, J., et al., 2018: Value-added impact from geostationary hyperspectral infrared sounding on nowcasting and forecasting high-impact weather events, 98th American Meteorological Society Annual Meeting, 07 – 12 January 2018, Austin, TX.

Li, Zhenglong; Li, J.; Wang, P.; Schmit, T. J.; Li, J.; Nagle, F. W.; Atlas, R.; Boukabara, S. A.; Pagano, T.; Blackwell, W. J.; Pereira, J. and Tewey, K. Evaluating the potential of CIRAS and MicroMAS-2 in mitigating the data gap of CrIS and ATMS. Conference on Integrated Observing and Assimilation Systems for the Atmosphere, Oceans, and Land Surface (IOAS-AOLS), 22nd, Houston, TX, 7-11 January 2018. American Meteorological Society, Boston, MA, 2018, Abstract 12.1.

Li, Zhenglong; Li, J.; Wang, P.; Lim, A.; Schmit, T. J.; Li, J.; Nagle, F. W.; Atlas, R.; Boukabara, S. A.; Pagano, T.; Blackwell, W. J.; and Pereira, J. Using CIRAS and MicroMAS-2 to mitigate the data gap of CrIS and ATMS, ITSC-XXI, Darmstadt, Germany, Nov 29 – Dec 5, 2017.

Wang, Pei; Li, Z.; Li, J.; Lim, A.; Schmit, T. J.; and Atlas, R. Value-added Impact from Geostationary Hyperspectral Infrared Sounder on high impact weather forecasting – demonstration with a quick regional OSSE, ITSC-XXI, Darmstadt, Germany, Nov 29 – Dec 5, 2017.

Huang, Allen; Li, Zhenglong; Li, Jun; Wang, Pei; Lim, Agnes; Schmit, Timothy; Li, Jinlong; Nagle, Fredrick; Atlas, Robert; Boukabara, Sid; Blackwell, William; Pagano, Thomas and Pereira, John. Quick regional OSSEs on CubeSat based IR/MW sounders on local severe storm forecasts. 2017 EUMETSAT Meteorological Satellite Conference, Rome, Italy, 2-6 October 2017. European Organization for the Exploitation of Meteorological Satellites (EUMETSAT), Darmstadt, Germany, 2017, Abstract 562.

## References

- Kleist, D. T., Parrish, D. F., Derber, J. C., Treadon, R., Wu, W.-S., & Lord, S. (2009). Introduction of the GSI into the NCEP global data assimilation system. *Weather Forecasting*, 24(6), 1691–1705. <https://doi.org/10.1175/2009WAF2222201.1>
- Lim, Agnes; Li, Z.; Jung, J. A.; Huang, A.; Woollen, J.; Nagle, F. W.; Quinn, G.; Healy, S. B.; Otkin, J.; Goldberg, M. D. and Atlas, R. Impact analysis of LEO hyperspectral sensor Ifov size on the next generation high-resolution NWP model forecast performance. Conference on Integrated Observing and Assimilation Systems for the Atmosphere, Oceans, and Land Surface, 21st, Seattle, WA, 21-26 January 2017. American Meteorological Society, Boston, MA, 2017
- Wang, X., Parrish, D., Kleist, D., & Whitacker, J. (2013). GSI 3DVar-based ensemble-variational hybrid data assimilation for NCEP Global Forecast System: Single-resolution experiments. *Monthly Weather Review*, 140, 4098–4117. <https://doi.org/10.1175/MWR-D-12-00141.1>
- Wu, W.-S., Purser, R. J., & Parrish, D. F. (2002). Three- dimensional variational analysis with spatially inhomogeneous covariances. *Monthly Weather Review*, 130(12), 2905–2916.



## **28. CIMSS Support for NPP and JPSS Data Assimilation Improvements and Data Denial Experiments**

**CIMSS Task Leader: James Jung**

**CIMSS Support Scientist: Sharon Nebuda**

**NOAA Collaborators: Arron Layns, Andrew Heidinger, Dennis Keyser, John Derber, Walter Wolf, Andrew Collard, Tom King, Yangrong Ling**

**Budget: \$243,000**

### **NOAA Long Term Goals:**

- Climate Adaptation and Mitigation
- Weather-Ready Nation

### **NOAA Strategic Goals:**

- Serve society's needs for weather and water
- Understand climate variability and change to enhance society's ability to plan and respond
- Support the nation's commerce with information for safe, efficient and environmentally sound transportation
- Provide critical support for the NOAA mission

### **CIMSS Research Themes:**

- Satellite Meteorology Research and Applications
- Satellite Sensors and Techniques
- Environmental Models and Data Assimilation

### **Objective**

Transition the National Centers for Environmental Prediction's (NCEP) Global Forecast System to the Cross-track Infrared Sounder (CrIS) Full Spectral Resolution (FSR) data and improve the data assimilation techniques to exploit more information from it.

### **Project Overview**

The goal of this proposal is to continue to facilitate the transition to, and improve the use of, the Joint Polar Satellite System/National Polar-orbiting Partnership (JPSS/NPP) Cross-track Infrared Sounder (CrIS) full spectral resolution (FSR, 2211 channels) in the National Centers for Environmental Prediction (NCEP) weather forecast models including the Global Data Assimilation System / Global Forecast System (GDAS/GFS). This effort will improve the use of the longwave channels and exploit the information from the higher spectral resolution midwave and shortwave channels. Improvements in obtaining information from this instrument will improve the weather model initialization and potentially the forecasts.

### **Milestones with Summary of Accomplishments and Findings**

#### ***Integrate NOAA-20 into the Global Statistical Interpolation (GSI) Software and Participate in the NESDIS NOAA-20 Readiness Tests***

Several changes to the NCEP GSI were required to use CrIS and ATMS from NOAA-20. Various files needed to be updated with the satellite ID, channel selection and quality control procedures. NESDIS-NCEP conducted a NOAA-20 pre-launch readiness test to exercise the end-to-end process of delivering and using NOAA-20 data. We participated in these tests to verify our quality control procedures and identify failure points. The software modifications to the NCEP GSI were developed within NCEP's software management system and were transitioned into



NCEP’s operational GDAS by the NCEP Environmental Modeling Center (EMC) on 18 December 2017.

### **Review VIIRS Cloud Information in the CrIS BUFR and Incorporate it into the GSI Radiance Thinning Routine**

Incorporating Advanced Very High Resolution Radiometer (AVHRR) cloud information for each Infrared Atmospheric Sounding Interferometer (IASI) field of view improved the sounder’s assimilation statistics significantly. Similar cloud information from the Visible Infrared Imaging Radiometer Suite (VIIRS) was incorporated into the CrIS data stream by NESDIS/STAR/ACCESS and transitioned to NESDIS/OSPO. We developed new CrIS thinning techniques to exploit the new cloud information and incorporated them into the GSI software. Verification statistics suggest improvements in finding clear CrIS profiles (less cloud contaminated) over the current methods. The surface temperature difference histogram (with respect to the NCEP GDAS) has a much more normal distribution whereas the current method is skewed toward warmer values. The number of clear profiles also increases by about 8%. Some inconsistencies with the cloud detection were observed at the higher viewing angles as shown in Figure 100. These inconsistencies were brought to the attention of the VIIRS Cloud Team and are being reviewed. If updates are made to the VIIRS cloud detection algorithm, we will conduct similar verification procedures to quantify any improvements. The code modifications containing the new thinning techniques were developed within NCEP’s software management system and were transitioned to NCEP Operations by EMC as part of a larger upgrade package.

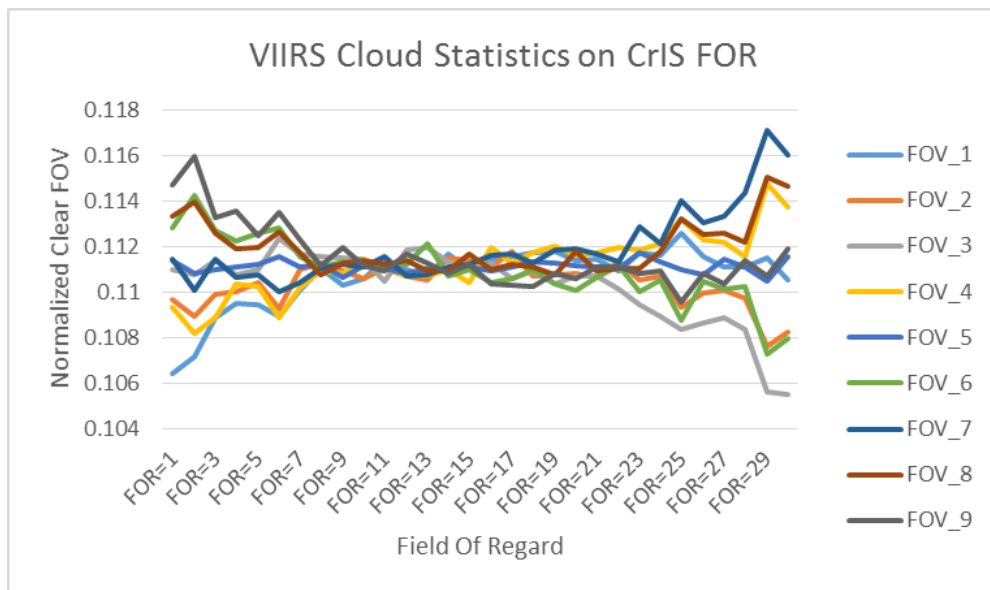

Figure 100. CrIS clear field of view statistics for each field of regard. Each field of regard should have about equal clear field of views from each detector. This is true near nadir but deviates at high scan angles.

### **Quantify the Suomi NPP CrIS Detector Differences**

One of the concerns within the Numerical Weather Prediction community is how large are the differences between the 9 CrIS detectors. If the calibration between the 9 CrIS detectors is not consistent, specific detectors will be rejected from the assimilation system. The European Center for Medium Range Forecast (ECMWF) is the most aggressive with this criteria by using only one detector from IASI (Collard and McNally 2006) and only using four detectors from CrIS (Eresmaa, et al., 2017). We have been looking at the differences between the 9 detectors. Eight of



the nine detector performances are very close. Detector seven in the midwave region has larger error than the others as shown in Figure 101.

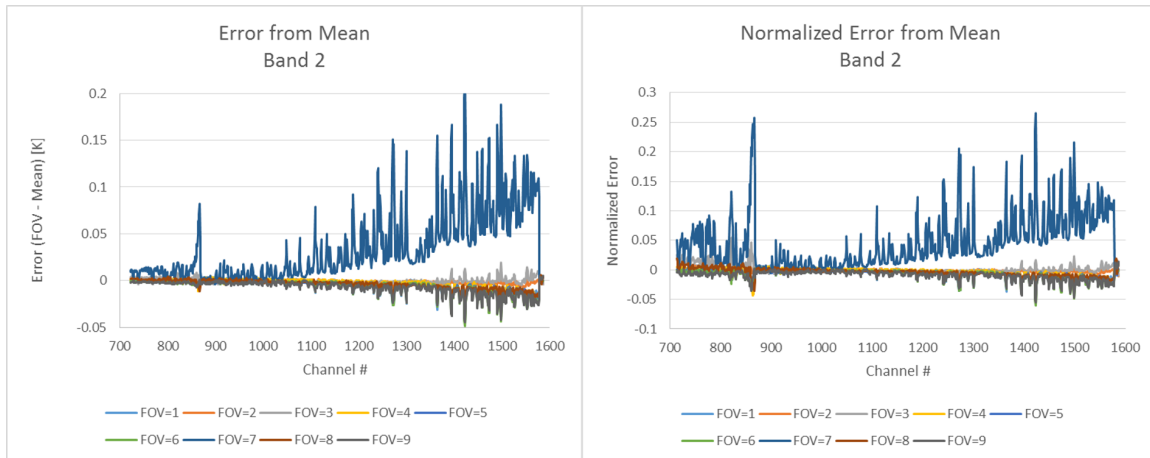

**Figure 101.** CrIS detector differences for band 2 (midwave). Left panel are errors in degrees Kelvin. Right panel are normalized errors. Detector 7 errors are up to 0.2K or 25% higher than the other detectors.

### Publications and Conference Reports

Bi, Li, and Coauthors 2017: All-sky Infrared Radiance Assimilation of Selected Humidity Sensitive IASI Channels at NCEP/EMC. *Proceeding of the 21<sup>st</sup> International TOVS Study Conference*, Darmstadt, Germany, 29 November – 5 December 2017.

Jung, J. A., and Coauthors 2017: Preparing for CrIS Full Spectral Resolution Radiances in the NCEP Global Forecast System, *Proceeding of the 21<sup>st</sup> International TOVS Study Conference*, Darmstadt, Germany, 29 November – 5 December 2017.

Jung, J. A. and coauthors, 2017: Advancements in CrIS Data Assimilation, *2017 JPSS Annual Science Team Meeting*, College Park, MD., 14-18 August 2017.

Jung, J. A., and coauthors, 2017: Initial Look at the VIIRS Cloud Products with CrIS for NCEP Data Assimilation in the GFS, *2017 JPSS Annual Science Team Meeting*, College Park MD, 14-18 August 2017.

### References

Collard, A. D., and A. P. McNally, 2009: The assimilation of Infrared Atmospheric Sounding Interferometer radiances at ECMWF, *Q. J. R. Meteorol. Soc.*, **135**, 1044-1058.

Eresmaa, R., J. Letertre-Danczak, C. Lupu, N. Bormann and A. P. McNally, 2017: The assimilation of Cross-track Infrared Sounder radiances at ECMWF, *Q. J. R. Meteorol Soc.*, **143**, 3177-3188.

## 29. CIMSS Cal/Val Activities in Support of the Calibration Work Group

**CIMSS Task Leader: Mathew M. Gunshor**

**CIMSS Support Scientist: James P. Nelson III**

**NOAA Collaborator: Timothy J. Schmit**

**Budget: \$96,000**





### **NOAA Long Term Goals:**

- Weather-Ready Nation

### **NOAA Strategic Goals:**

- Serve society's needs for weather and water
- Provide critical support for the NOAA mission

### **CIMSS Research Themes:**

- Satellite Meteorology Research and Applications
- Satellite Sensors and Techniques

### **Objective**

Support the GOES-R Calibration Working Group (CWG) in post-launch test activities for GOES-R series Advanced Baseline Imager (ABI) data, especially in the area of serving user's needs and best interests.

### **Project Overview**

CIMSS assists the GOES-R CWG in preparing NOAA and users for the GOES-R era. Experience with the legacy GOES-series on science checkouts and radiance quality assurance, as well as involvement on the GOES-R AWG developing a system for analyzing ABI product output, have been valuable to the CWG's mission of providing the most accurate data possible.

### **Milestones with Summary of Accomplishments and Findings**

Proposed tasks:

- Assist CWG in analysis of calibration issues and their effects on products
  - Supporting L1b calibration and ensuring ABI data quality; Analyzing the impact of L1b issues on users; Assisting CWG through PLT/PLPT; Initial on-orbit analysis / starting ABI PLT/PLPT.
- Assist CWG in analysis of calibration and navigation on JMA's AHI.
  - Support GOES-R CVCT INR efforts.
- Report on issues addressed by CIMSS that affect current GOES radiance quality.
  - Attend regular CWG telecons, reporting on findings when appropriate.
  - Report pertinent activities to the CWG weeklies.

Issues raised to the CWG and/or analyzed by CIMSS:

- Stray Light outside Solar Avoidance Zone
  - The ABI is designed to not directly scan the sun and avoids scanning areas around the edge of the earth when the sun is too close to the region scanned. "Leaked" stray light can still impact the shortwave IR band (3.9um).
- PICA – A periodic calibration anomaly was found to be affecting ABI data calibration.
  - CIMSS assisted in discovery and analysis; tested the fix before implementation.
- Cold Pixels Near Fires
  - Artificially cold pixels appear near especially hot (fire) pixels in the 3.9um band due to remapper. Continues to be an issue.
- Space Look Stray Light
  - Legacy GOES issue of space looks getting contaminated by stray light on GOES-13. CIMSS algorithm detects from imagery when this has happened.
- Visible Back Scatter
  - When the sun is essentially behind GOES such that the satellite is scanning the part of Earth directly in the sun/satellite/earth line there is visible backscatter



detected. This at first was believed to be a calibration anomaly, but is really just a feature. CIMSS showed that it was on GOES-13 as well. The higher quality ABI data and higher temporal scanning, as well as more vis/near-IR bands, made it more apparent on ABI.

- GOES-17 Calibration Coefficients
  - Sample GOES-17 data provided by GOES-R Program for testing had GOES-16 coefficients for converting L1b radiance to L2 Cloud and Moisture Imagery (CMI) values (reflectance factor or brightness temperature). GOES-17 coefficients were calculated and provided to GOES-R program for implementation.
- Potential Navigation issue at 75.2W
  - GOES-East is operating from 75.2W but ABI data are remapped to a fixed grid format centered at 75W. For certain radiative transfer calculations, some applications should be using the 75.2W number, but for navigation accuracy, navigation transformation calculations should be using 75W. CIMSS demonstrated the navigation discrepancy that will arise for users not using the right metadata values as the Program plans to change a variable from 75 to 75.2.

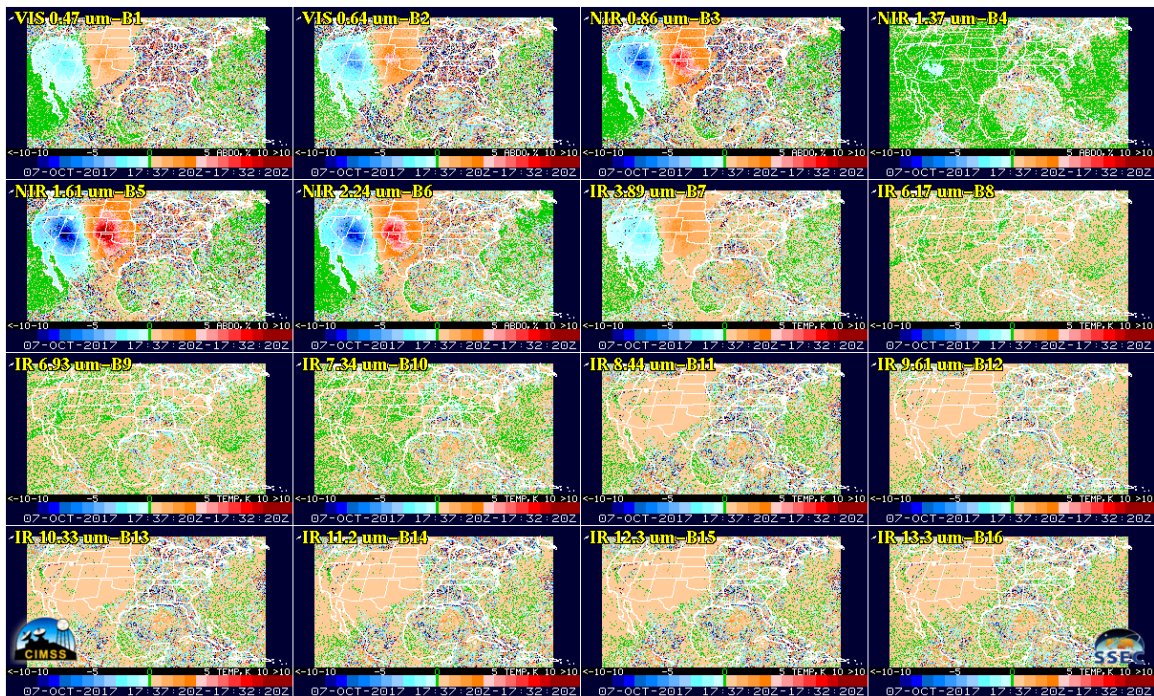

Figure 102. GOES-16 ABI time difference 16 panel CONUS image showing the visible backscatter issue, easily apparent in most as a darker/brighter couplet in VIS/NIR bands. Time difference images are produced at CIMSS in real-time to assist with image quality analysis.

### 30. CIMSS Support to GOES-R Calibration/Validation Deployment Support For Scanning HIS (S-HIS)

CIMSS Task Leaders: Joe Taylor, David Tobin

CIMSS Support Scientists: Hank Revercomb, Robert Knuteson, Ray Garcia, David Hoese, Dan DeSlover

NOAA Collaborators: Dan Lindsey, Steve Goodman, Frank Padula, Aaron Pearlman



**Budget: \$329,838**

**NOAA Long Term Goals:**

- Weather-Ready Nation

**NOAA Strategic Goals:**

- Serve society's needs for weather and water
- Support the nation's commerce with information for safe, efficient and environmentally sound transportation
- Provide critical support for the NOAA mission

**CIMSS Research Themes:**

- Satellite Meteorology Research and Applications
- Satellite Sensors and Techniques
- Education and Outreach

**Objective**

The primary objective of this project is radiometric calibration validation of the GOES-16 ABI instrument via intercomparison with the high-altitude airborne S-HIS sensor. The S-HIS was deployed on the NASA ER-2 in 2017 for this project.

**Project Overview**

GOES-16 conducted a calibration and validation field campaign in 2017. The FY17 (Year 2) funding was used to deploy the UW-Madison SSEC Scanning High-resolution Infrared Sounder (S-HIS) on the ER-2 aircraft, conduct preliminary analyses, and conduct post-mission end-to-end laboratory calibration verification of the S-HIS. Additional FY18 (Year 3) funds are expected to provide further support for the final analyses, publications, and continue post-deployment laboratory characterization of the S-HIS instrument. Routine instrument maintenance and field deployment preparation were the primary activities in FY16 (Year 1).

**Milestones with Summary of Accomplishments and Findings**

- Science flights were conducted from NASA Armstrong and Werner Robins AFB. On-site and remote support of the S-HIS instrument was provided by UW-SSEC researchers.
- Preliminary analyses of S-HIS data for each flight was completed in a timely fashion during the campaign (typically within 12-24 hours).
- Preliminary S-HIS data products were uploaded to the project web portal following each flight (typically within 24-48 hours).
- Mission planning support was provided throughout the field deployment.
- Post-mission end-to-end radiometric calibration verification of the S-HIS was completed at the SSEC. All results were well within the predicted radiometric uncertainty.
- Post mission calibration-validation analyses of the GOES-16 ABI instrument using co-located S-HIS data is in progress. Observation to observation (ABI – S-HIS) analyses for ABI North-South-Scan and Mesoscale data collects for the ABI calibration validation focus days (2017-03-23, 2017-03-28, 2017-04-13) has been completed. At this time, all comparison results are within the expected radiometric uncertainty.
- Material for AMS Annual Meeting presentations was provided to the NOAA collaborators (Frank Padula).
- An example 3-panel comparison plot for a single ABI NSS scan is shown in Figure 103.

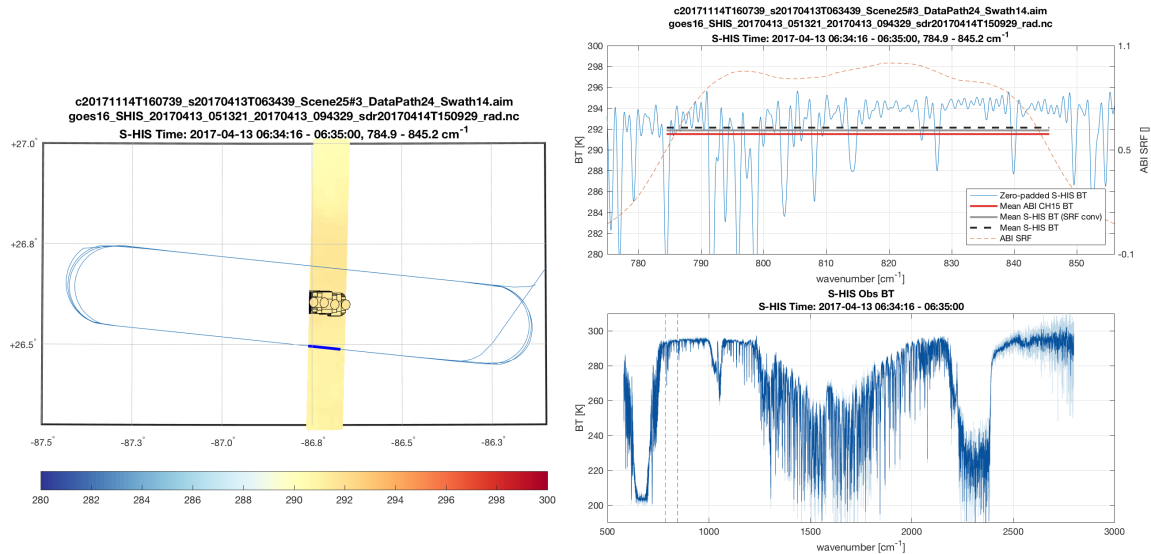

**Figure 103.** Example 3-panel comparison plot for a single ABI North-South-Scan (ABI CH16, 2017-04-13, 180739 UTC). Similar comparisons have been made for all ABI IR channels and all 3 90-minute Mode 25 ABI cal-val data collects. There are 1206 NSS data files per channel in each 90-minute Mode 25 data collect. **Left:** brightness temperature map of fields of view being compared (footprints that satisfy the co-location conditions are outlined in black). **Top right:** Mean S-HIS spectrally resolved brightness temperature (oversampled, blue), mean S-HIS brightness temperature convolved with ABI SRF (grey), mean ABI brightness temperature (red), and ABI normalized SRF (dashed red, plotted vs right hand y-scale). **Bottom right:** S-HIS spectra used in the mean.

## 31. CIMSS Support to Participate in Enhanced Measurements During GOES-R Post Launch Testing for ABI Baseline and Future Project Validation 2017

**31.1 SPARC Deployment to Sheboygan, WI, for GOES-16 Level Validation During 2017 Lake Michigan Ozone Study (LMOS)**  
**CIMSS Task Leader: Timothy Wagner**  
**NOAA Collaborator: Brad Pierce**  
**Budget: \$91,000**

### NOAA Long Term Goals:

- Climate Adaptation and Mitigation
- Weather-Ready Nation
- Resilient Coastal Communities and Economies

### NOAA Strategic Goals:

- Serve society's needs for weather and water
- Understand climate variability and change to enhance society's ability to plan and respond
- Protect, restore and manage the use of coastal and ocean resources through an ecosystem approach to management

### CIMSS Research Themes:

- Satellite Meteorology Research and Applications



- Satellite Sensors and Techniques
- Environmental Models and Data Assimilation

## Objective

To participate in the Lake Michigan Ozone Study using SSEC's Portable Atmospheric Research Center.

## Project Overview

The Space Science and Engineering Center (SSEC) Portable Atmospheric Research Center (SPARC) is a ground-based mobile atmospheric profiling system that actively and passively profiles that thermodynamic and kinematic structure of the planetary boundary layer. In 2017, SPARC participated in the Lake Michigan Ozone Study, a NASA/NOAA/EPA project dedicated to investigating why smaller communities along Wisconsin's Lake Michigan shore were routinely exceeding their ground-level ozone attainment levels despite little local production of ozone precursors. LMOS deployed NASA and private aircraft, a NOAA research vessel, mobile transect observations, and instrumented field sites along hundreds of kilometers of shoreline in order to characterize the environment in which high ozone cases were forming. As part of this SPARC was part of a ground-based supersite in Sheboygan, Wisconsin, to observe the evolution of the boundary layer during IOPs while continuously collecting radiometric and meteorological observations critical for GOES-16 ABI and product validation. The continuous observations hosted by SPARC also fostered the opportunity to validate GOES-16 ABI Legacy Atmospheric Profile (LAP) retrievals throughout the diurnal cycle in a variety of thermodynamic states.

## Milestones with Summary of Accomplishments and Findings

AERI observations of the near and thermal infrared spectrum were taken continuously throughout LMOS 2017, and these spectral observations were post-processed after the experiment to produce vertical profiles of temperature and water vapor mixing ratio, along with their associated one  $\sigma$  uncertainties, at a 5 min temporal resolution. The retrieved profiles were used to validate the LAP product at the Sheboygan, WI, deployment site, and the results of that analysis were included in the GOES-16 ABI L2+ LAP Products Provisional PS-PVR on February 22, 2018.

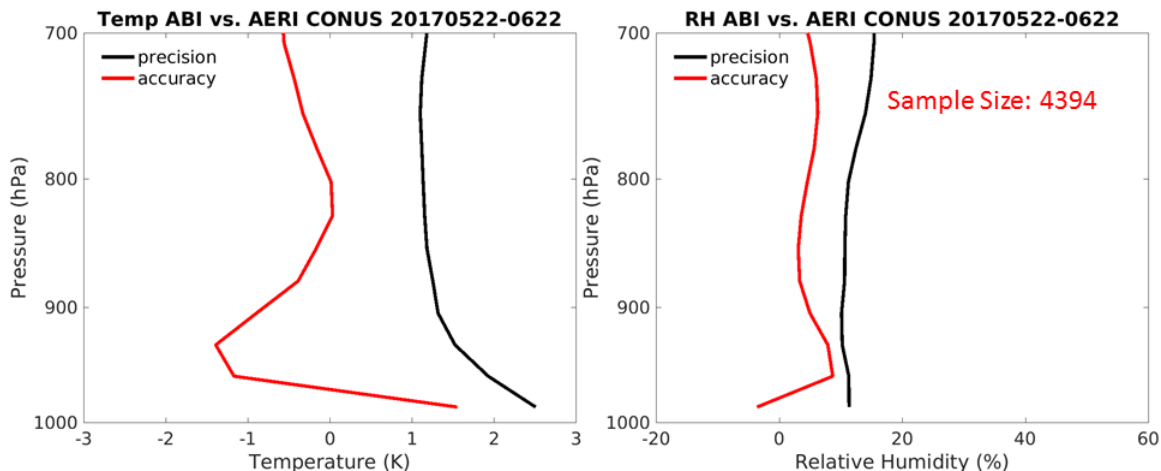
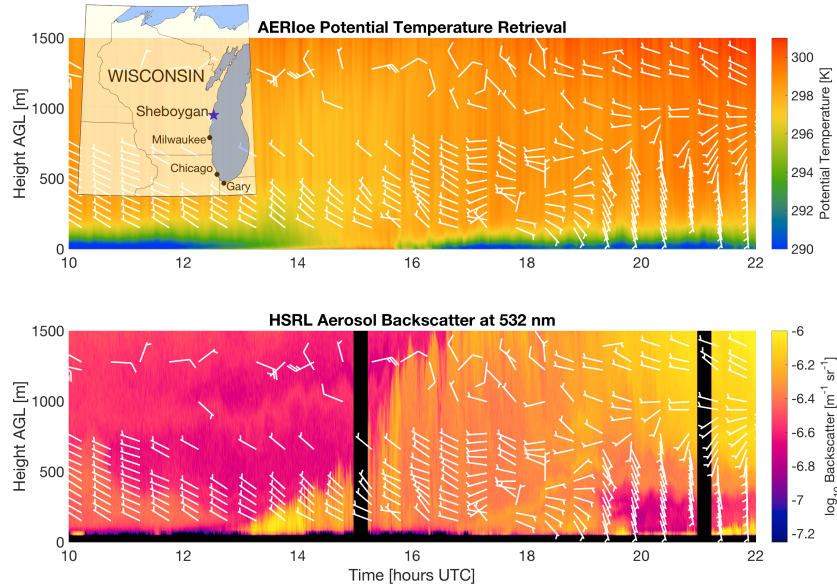

**Figure 104. Comparison between colocated GOES-16 ABI and AERI Temperature and relative humidity profiles during the LMOS 2017 field campaign. These comparisons were used to demonstrate that the LAP retrievals pass the product specifications.**

From the perspective of the LMOS experiment, the SPARC instrumentation provided many valuable insights into atmospheric processes that impact ground-level ozone concentrations. It has



been known for some time that lake breezes have a role to play in elevated ozone concentrations in shoreline communities, but the observations collected during LMOS provided unique insight into the processes at work. Precursors are formed in the industrial centers along southern Lake Michigan while predominately southerly transport keeps them confined to the lake itself. However, lake breezes induce a significant easterly component to the wind, transporting the precursors to land. At the same time, the shallow cold air advection induced by the breeze traps the precursors under an inversion and prevents them from being mixed away from the surface. Together, these effects contribute to a large concentration of precursors hundreds of kilometers away from their source.



**Figure 105.** This figure shows time/height cross sections of temperature (top) and aerosol backscatter (bottom) for a lake breeze event on 2 June 2017 as measured by SPARC instrumentation. Wind profiles from the SPARC’s Doppler lidar are overlaid on each cross section. Times are in UTC (local time is UTC – 5). Rapid surface cooling in the overnight hours facilitated the development of an inversion, clearly visible as the warm layer overlying the cooler layer in the pre-sunrise hours. Following sunrise, daytime heating contributed to the growth of the PBL (seen in the aerosol backscatter image) and the erosion of the inversion. However, the imbalanced heating of the land relative to the water surface induced a lake breeze which manifests itself in the observations as the turning of the wind vectors, the reduction in aerosol backscatter indicating the advection of cleaner maritime air, and the creation of a new shallow inversion.

## References

Wagner, T. J., D. T. Turner, and P. K. Klein, 2018: A new generation of ground-based mobile platforms for active and passive profiling of the atmospheric boundary layer. *Bull. Amer. Meteor. Soc.*, in revisions.

## 31.2 GOES-16 Level 2 Cryosphere Validation in Green Bay

**CIMSS Task Leader: Yinghui Liu**

**CIMSS Support Scientist: Aaron Letterly**

**NOAA Collaborator: Jeff Key**

**Budget: \$13,000**

### NOAA Long Term Goals:

- Climate Adaptation and Mitigation
- Weather-Ready Nation



- Healthy Oceans
- Resilient Coastal Communities and Economies

#### **NOAA Strategic Goals:**

- Serve society's needs for weather and water
- Understand climate variability and change to enhance society's ability to plan and respond
- Protect, restore and manage the use of coastal and ocean resources through an ecosystem approach to management
- Support the nation's commerce with information for safe, efficient and environmentally sound transportation
- Provide critical support for the NOAA mission

#### **CIMSS Research Themes:**

- Satellite Meteorology Research and Applications
- Satellite Sensors and Techniques
- Education and Outreach

#### **Objective**

To participate in the Great Lakes Winter Experiment to collect measurements in support of GOES-16 product validation.

#### **Project Overview**

During February 6-24, 2017, with funding provided by NOAA (GOES-R) and NASA, the Naval Research Laboratory (NRL) P3 aircraft was scheduled to fly over part of the Great Lakes region during the transit flight from Colorado to the Patuxent Naval Base. Scientists from a number of government agencies and universities were to collect measurements of snow and lake ice properties in Green Bay, Wisconsin and Michigan's Upper Peninsula. This field campaign is known as the Great Lakes Winter Experiment (GLAWEX) in 2017. There were GLAWEX campaigns in 1997 and 2002 that focused on the use of SAR for ice mapping.

The purpose of the CIMSS/NOAA portion of the GLAWEX campaign was to collect ground-based and airborne measurements in support of GOES-16 ABI Baseline and Future Product validation during the GOES-16 Post Launch Test (PLT) through participation in the GLAWEX. JPSS (S-NPP) product validation would also be performed.

#### **Milestones with Summary of Accomplishments and Findings**

A cracked windshield on the NRL P3 prevented flight during the field measurement portion of GLAWEX on Feb 26-27, 2017. The ice in the Green Bay was unseasonably thin in some areas, and measuring lake ice characteristics on the thin lake ice was dangerous and challenging. However, Jeff Key from NOAA/NESDIS, Aaron Letterly and Yinghui Liu from CIMSS, and Matt Welshans and Sean Helfrich from National Ice Center managed to collect a number of ice measurements in Sturgeon Bay, WI and Red River County Park areas, while Jeff Key and Matt Welshans boarded the Coast Guard icebreaker *Mobile Bay* to take ice measurements further offshore, obtaining a number of samples in the central portion of Green Bay. Ice thickness, ice/snow interface temperature, snow depth, snow surface temperature, and meteorological conditions were observed over the course of three days (February 25-27). Figure 106 shows the team making measurements over Green Bay.



Figure 106. Measurements of lake ice characteristics over Green Bay during the GLAWEX in February 2017.

We are currently archiving and organizing all the in situ observations. Figure 107 shows the ice thickness measurements during the GLAWEX in February 2017. The next step is to collocate these in situ observations with satellite retrievals from GOES-16 ABI and from Suomi NPP VIIRS, then calibrate and validate the satellite retrievals of ice surface temperature and ice thickness.

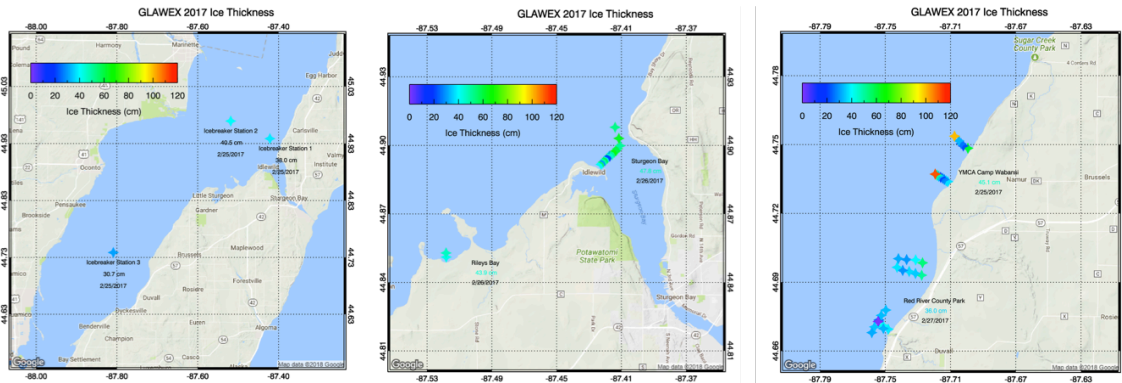

Figure 107. Ice thickness measurements during the GLAWEX in February 2017.

### 32. CIMSS Participation in Sensing Hazards with Operational Unmanned Technology (SHOUT)

CIMSS Task Leader: Chris Velden

CIMSS Support Scientist: Sarah Griffin

NOAA Collaborator: Gary Wick (ESRL)

Budget: \$75,000





### **NOAA Long Term Goals:**

- Weather-Ready Nation

### **NOAA Strategic Goals:**

- Serve society's needs for weather and water
- Provide critical support for the NOAA mission

### **CIMSS Research Themes:**

- Satellite Meteorology Research and Applications

### **Primary Objective**

Provide tailored satellite data and products for weather hazard avoidance during SHOUT Global Hawk science and data collection missions.

### **Project Overview**

The UW-CIMSS team has a strong history of supporting scientific field campaigns with crucial meteorological satellite data and tailored products. The expertise extends into developing, interpreting and utilizing these satellite products to support research aircraft hazard avoidance, as well as general mission support and research analyses. The PI and his team have participated in many recent projects, including NASA's HS3 field campaign that also utilized the Global Hawk. Many of these were in very successful collaborations with NOAA and NESDIS. We have been asked by NOAA to collaborate and provide support for the SHOUT program. This field campaign will operate at times in a tough environment for aircraft reconnaissance, and the over-ocean nature will mean that real-time satellite data/products from a variety of platforms will be crucial to mission planning and safety. CIMSS will provide these satellite data in a timely manner to the project, and tailor the derived products to fit the needs of SHOUT.

### **Milestones with Summary of Accomplishments and Findings**

#### ***Support for the 2017 SHOUT and EPOCH Field Campaigns***

For the 6<sup>th</sup> straight year, CIMSS provided satellite-based hazard avoidance products to assist scientists and pilots with navigation of the unmanned Global Hawk flights over tropical cyclones. In 2017, the NOAA SHOUT field campaign was joined by the NASA EPOCH project, and ran during the month of August encompassing many science missions with the Global Hawk. Since the primary targets of these missions were tropical cyclones, the airplane was operating in conditions that posed unique challenges in many ways. Remote-sensing imagery and derived products were crucial to successful mission planning, decision-making, and execution, and the CIMSS team made this data available to the mission operations center in real time from multiple satellite platforms, tailored specifically to the SHOUT/EPOCH region of interest.

Satellite data product interpretation added a key element to the mission planning through the CIMSS team expertise in this area. Examples of specific real-time UW-CIMSS tailored satellite products made available for the field campaign were:

- High-density wind vectors from GOES processed at hourly intervals;
- Diagnostic fields (shear, divergence, vorticity) from these wind vector fields;
- Cloud-Top Heights using latest NESDIS algorithms;
- Overshooting Tops identification; and
- TPW analyses using the CIMSS MIMIC algorithm (continuously updating with seamless animation).



Specific tasks accomplished were:

- Provided 24/7 support of CIMSS satellite-derived products for real-time use during the field campaign missions,
- Derived meteorological variables from satellite data to help meet mission requirements and the research goals of SHOUT/EPOCH, and
- Participated in the SHOUT/EPOCH planning meetings.

CIMSS provided two especially important real-time products for Global Hawk hazard avoidance: cloud-top height (CTH) and tropical overshooting tops (TOTs). The CTH product was used to identify the very cold and high cloud tops in the central dense overcast region of the tropical cyclone to ensure the GH overflights were maintaining a safe distance from the cloud tops. The TOTs were used to identify areas of potential updrafts, which could cause turbulence. These products were provided to the Global Hawk pilots and support teams in two different ways: 1) rapidly-updating images on the NASA Mission Tools Suite (MTS), which allowed scientists to integrate the satellite data with other information in order to accurately estimate the time and distance between the GH and potential hazards, and 2) animated sequences of these products were available on an external website housed at CIMSS. An example product display during one of the Global Hawk missions is shown below.

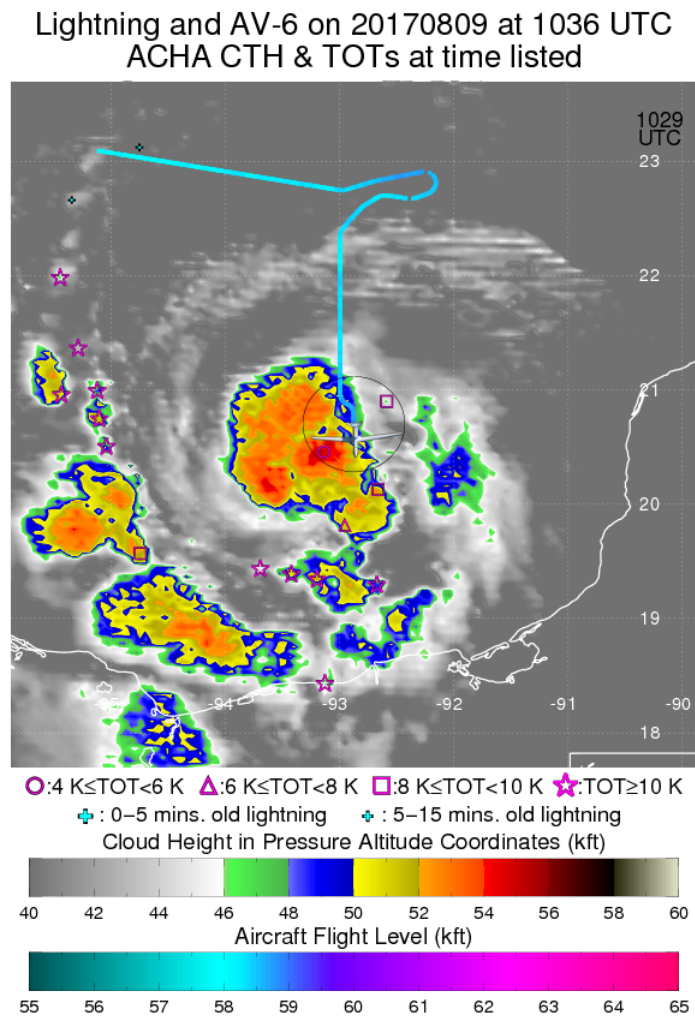

**Figure 108. Global Hawk (located at airplane symbol) diverts its flight path to avoid a tropical overshooting top (circle symbol) in high cloud tops during an over-flight of Hurricane Franklin on August 9, 2017.**



## Publications

Griffin, S. M. and C. S. Velden, 2018: Hazard Avoidance Products for Convectively-Induced Turbulence in Support of High-Altitude Global Hawk Aircraft Missions. *Pure Appl. Geophys.*, 1420-9136, 1-11.

## 33. RTAP Reduced Chemistry Model Integration

**CIMSS Task Leader: Allen Lenzen**

**NOAA Collaborator: R. Bradley Pierce, Vijay Tallapragada**

**Budget: \$140,000**

### NOAA Long Term Goals:

- Weather-Ready Nation

### NOAA Strategic Goals:

- Serve society's needs for weather and water
- Provide critical support for the NOAA mission

### CIMSS Research Themes:

- Environmental Models and Data Assimilation

## Objective

This project will support the development and testing of a reduced chemical mechanism within the NOAA's Next Generation Global Prediction System (NGGPS) atmospheric composition capability.

## Project Overview

Unified chemical mechanisms that account for both stratospheric and tropospheric chemistry typically require transport of up to 70 chemical species and involve hundreds of chemical reactions, requiring computational resources that often preclude operational implementation. This project supports the NOAA Research Transition Acceleration Program (RTAP) through development and testing of a reduced chemistry mechanism within the Next Generation Global Prediction System (NGGPS) atmospheric composition capability. The reduced chemical mechanism includes only 12 transported species and is therefore computationally efficient enough for operational use. Prediction of atmospheric composition will result in improved predictions of ozone radiative heating in the upper troposphere and lower stratosphere, supports data assimilation through better use of infrared radiance measurements, supports implementation of aerosol models within NGGPS by providing oxidation rates, and supports the National Air Quality Forecasting Capability (NAQFC) through improved estimates of background concentrations of ozone and ozone precursors.

## Milestones with Summary of Accomplishments and Findings

### Recent Progress

- Developed and validated IDL software to compute regression coefficients for non-transported species (CH<sub>4</sub>, N<sub>2</sub>O, CLNO<sub>3</sub>) and stratospheric chlorine/bromine ozone loss using archived fields from the RAQMS Aura Reanalysis. (See Figure 109).
- Developed and validated IDL software to map Hemispheric Transport of Air Pollution (HTAP) emissions onto FV3 Cubed Sphere tiles.



- Ported National Unified Operational Prediction Capability (NUOPC) EMC\_FV3GFS-GSDCHEM on to S4.
- Provided feedback to GSDCHEM and NUOPC development team on problems with exchanging information between the ATM and CHM model components.
- Testing computational overhead associated with NUOPC coupling by running GFS ozone physics within NUOPC coupler – can be done with exchange of existing FV3 3D fields.

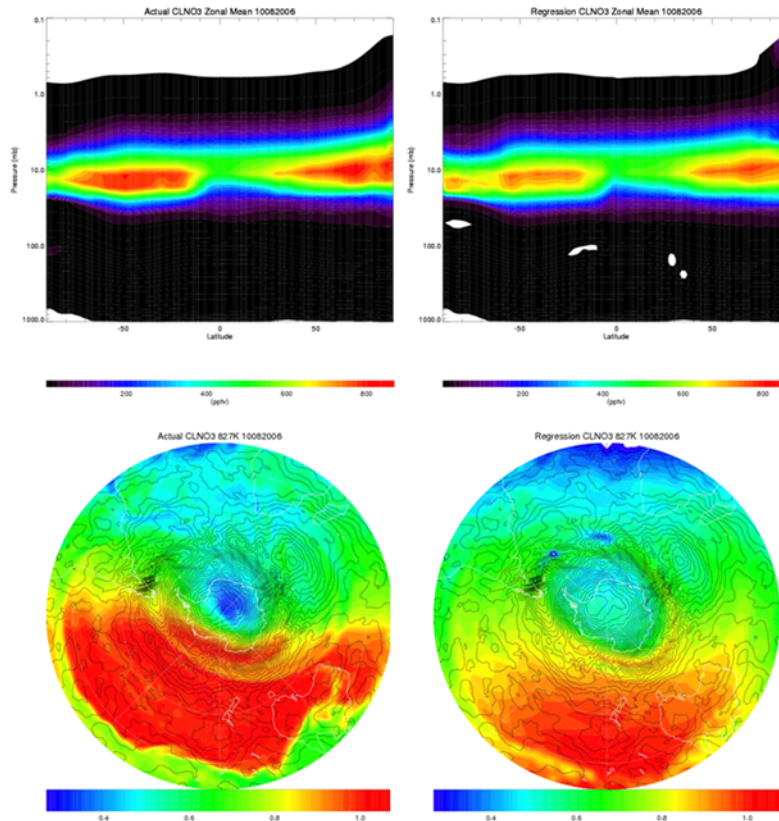

Figure 109. CLNO3 Regression Testing: Monthly regression coefficients for a 3<sup>rd</sup> order Potential Vorticity (PV) and 1<sup>st</sup> order solar zenith angle have been developed and tested using daily chemical analyses from the 11 year (2006-2016) RAQMS Aura Chemical and Aerosol Reanalysis. The figure shows the Actual (upper left) and Regression (upper right) zonal mean CLNO3 distributions (pptv) and stereo projections of the Actual (lower left) and Regression (lower right) Southern Hemisphere CLNO3 (ppbv) on the 827K isentropic surface, which is at ~10mb.

### 34. CrIS/OMPS and TES Ozone Retrievals in Support of the FIREX Intensive Campaign

CIMSS Task Leader: Allen Lenzen  
CIMSS Support Scientist: Hong Zang  
NOAA Collaborator: Brad Pierce  
Budget: \$69,000

#### NOAA Long Term Goals:

- Weather-Ready Nation

#### NOAA Strategic Goals:

- Serve society's needs for weather and water



- Provide critical support for the NOAA mission

#### **CIMSS Research Themes:**

- Satellite Sensors and Techniques
- Environmental Models and Data Assimilation

#### **Objective**

Collaborate with JPL in support NOAA FIREX field campaign by providing near-real-time joint CrIS/OMPS tropospheric ozone and CrIS carbon monoxide products and assimilate these products within the Real-time Air Quality Modeling System (RAQMS).

#### **Project Overview**

The project focuses on joint tropospheric ozone products from CrIS/OMPS and their assimilation within a nested global to regional air quality modeling system in support of the NOAA FIREX campaign. The spectral resolution of infrared hyperspectral CrIS measurements restricts the sensitivity of inferred ozone to the upper troposphere. OMPS measurements are designed for total column ozone only. The JPL team has demonstrated that the combination of radiances from these two instruments provides lower tropospheric ozone sensitivity. This sensitivity permits quantification of ozone in the outflow regions of biomass burning. We will compare these retrieved ozone profiles with the NOAA operational CrIS/ATMS NUCAPS retrieval algorithm. The CrIS/OMPS and NUCAPS ozone, along with full spectral resolution CrIS CO retrievals will be assimilated into the RAQMS/GSI analysis/forecast system.

#### **Milestones with Summary of Accomplishments and Findings**

***Milestone 1: Provide low latency CrIS and OMPS UV radiances for multi-spectral ozone (O3) and carbon monoxide (CO) retrievals at JPL and NUCAPS products for validation activities utilizing the CIMSS Direct Broadcast (DB) Community Satellite Processing Package (CSPP) capabilities.***

Generation of the CrIS Full Spectral Resolution SDR's in real-time for all the CONUS direct broadcast sites for both SNPP and JPSS-1 has been completed. Testing of the software to generate the OMPS SDR data has been completed and OMPS SDR data is generated in real-time. A crontab script will be used to post the OMPS SDR data for JPL to acquire for real-time processing. At this point, we only have capabilities to generate SNPP OMPS SDR data.

***Milestone 2: Perform 3D-var global retrospective ozone and CO assimilation (1.0° x 1.0°) using CONUS CrIS/OMPS O3 and CrIS CO in addition to NASA MLS and OMI ozone columns for July-August 2015 during the exceptional Western US fire events.***

We have changed our focus to the 2017 wildfire season for our retrospective assimilation runs and begun comparisons between NUCAPS, JPL Multi-Spectra, Multi Species, Multi-Sensors (MUSES) (Bowman et al, 2016), and the Real-time Air Quality Modeling System (RAQMS) carbon monoxide (CO) predictions during a large wildfire event in August 2017. Comparisons show generally good agreement between MUSES, NUCAPS and RAQMS except in the vicinity of low level clouds, where the NUCAPS retrieval shows cloud artifacts.

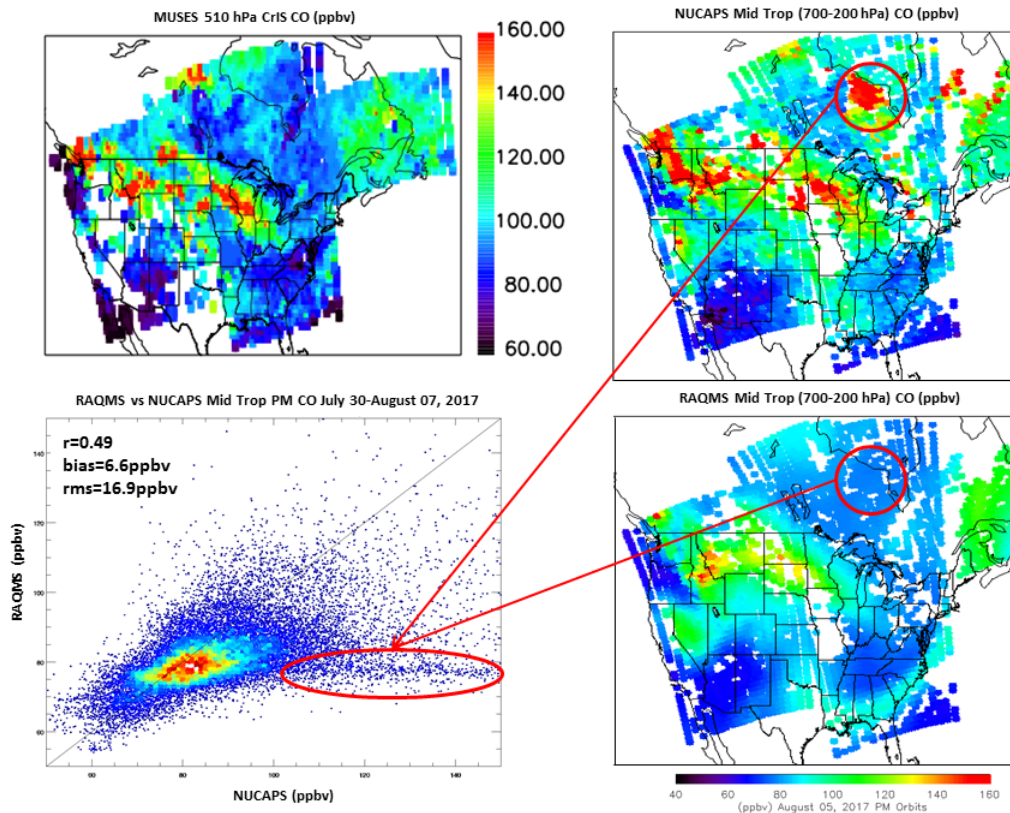

Figure 110. Comparison between MUSES (upper left), NUCAPS (upper right), RAQMS (lower right) mid-tropospheric carbon-monoxide retrievals on August 05, 2017. The lower left panel shows RAQMS vs NUCAPS for July 30-August 07, 2017 and highlights the cloud artifacts.

### Publications and Conference Reports

Fu D., et al, Multi-spectra, multi-species, multi-satellite retrievals of trace gases: updates on validation and science applications , NASA Sounder Science Team Meeting October 24-26, 2017

### References

Bowman, Kevin W., Helen M. Worden, and John R. Worden. "High-Resolution Tropospheric Carbon Monoxide Profiles Retrieved from CrIS and TROPOMI." *Atmospheric Measurement Techniques* 9.6 (2016): 2567-79.

## 35. GOES-S Teacher Workshop at Lockheed Martin

**CIMSS Task Lead: Margaret Mooney**

**NOAA Collaborators: Steve Goodman and Tim Schmit**

**Budget: \$9,000**

### NOAA Long Term Goals:

- Climate Adaptation and Mitigation
- Weather-Ready Nation
- Resilient Coastal Communities and Economies



### **NOAA Strategic Goals:**

- Serve society's needs for weather and water
- Understand climate variability and change to enhance society's ability to plan and respond
- Provide critical support for the NOAA mission

### **CIMSS Research Themes:**

- Education and Outreach

### **Objective**

Promote GOES-R Satellite Series capabilities to educators.

### **Project Overview**

The Cooperative Institute for Meteorological Satellite Studies (CIMSS) organized a GOES-S teacher workshop hosted by Lockheed Martin on August 23<sup>rd</sup>, 2017.

### **Milestones with Summary of Accomplishments and Findings**

Forty educators registered and thirty attended the exciting 1-day event. For those that made it, a unique experience ensued.

A GOES-R 'star-studded' line-up kicked off the day with presentations by Laird Kantruss from Lockheed Martin (LM), GOES-R Program Director Mike Stringer and GOES-R Science Lead Steve Goodman. In addition, National Weather Service (NWS) meteorologist Paul Schlatter presented on GOES-16 contributions to the NWS Weather-Ready Nation initiative and Lockheed Martin Danielle Hauf shared LM Generation Beyond resources. And that was just the morning!

After lunch, educators were wowed by an up-close view of the GOES-S Satellite in the clean room, along with finished but unassembled parts of GOES-T. The experience was awe-inspiring. As one teacher shared on the evaluation, "It was amazing to see the actual spacecraft!" (See Figure 2 on page 26 for a group photo.)

The full agenda and links to power point presentations are on-line at <http://cimss.ssec.wisc.edu/education/goesr/GOES-S.html>

The GOES-R program supported the teachers' attendance through the GOES-R Education Proving Ground (<http://cimss.ssec.wisc.edu/education/goesr/>) by providing \$300 stipends to teachers living outside of the Colorado counties of Arapahoe, Douglas, Jefferson and Adams, which surround Lockheed's hometown of Littleton and includes the city of Denver. Local teachers from those 4 counties were eligible for \$100 stipends to pay for substitute teachers. Five informal educators from the Space Foundation in Fort Collins and one from UCAR in Boulder attended without stipend support. All educators were welcomed and encouraged to attend, especially classroom teachers who interact with 100s of students each year, perfectly positioned to reach scientists and citizen scientists of tomorrow.

As a result of the workshop, all participants were guaranteed official invites to attend the GOES-S launch in March 2018, and over a dozen attended! Other workshop outcomes included the collection of ideas to promote the GOES-S launch, including a Google Expedition that would allow hundreds of thousands of students to experience the GOES-S launch virtually. CIMSS applied several times, but Google did not respond.



Workshop evaluations collected at the end of the day resulted in seventeen participants giving the workshop an overall rating of “excellent”, ten chose “very good” and three chose “good”. Comments collected indicated that some teachers found the science content challenging but everyone fully appreciated the experience. Full evaluations follow.

GOES-S Teacher Workshop Evaluations		Lockheed Martin Littleton Campus, August 23, 2017				
		Not at all - 1	Very Little - 2	Somewhat - 3	A fair amount - 4	A great deal - 5
<b>Benefits</b>						
To what extent did the experience:						
Increase your understanding of potential applications of satellite remotes				1	10	20
Technologies to teach & study Earth Science topics in your classroom						
Increase the likelihood that you will use the new GOES-16 Data and resources demonstrated at this workshop in your classroom				2	8	21
<b>Content</b>						
To what extent was the content covered:						
Easily understandable				6	20	6
Relevant to your needs				6	14	11
Suitable to your current knowledge		1		5	14	11
In accordance with your expectations				3	11	16
<b>Delivery</b>						
To what extent was the information:						
Well Organized				4	9	18
Presented at the right pace		2		4	7	18
To what extent did presenters:						
Emphasize important points					12	19
Allow for sharing of ideas and experiences				1	5	25
<b>Overall Workshop Rating</b>	Poor	Fair	Good	Very Good	Excellent	
			3	10	17	
<b>Comments:</b>						
I learned a ton and at times it was hard to follow but I am looking forward to incorporating much information in my classroom						
Why weren't applications to climate change ever discussed?						
Some of the lectures were way over my head, others (regarding pedagogy) were things I already knew - maybe add more differentiation for different levels of subject knowledge?						
So much information. I would like more time spent on actual classroom application. The ending discussion was perfect.						
The morning content was a little above my head but the afternoon was great!						
I am excited to use some GOES imaging to talk about the EM spectrum in physics.						
Add more interactivity						
Provide wifi						
Provide power points in advance						
Thank you so much for the opportunity! In the future, it would be nice if there were more chances for getting up and moving around.						
I am very excited about the launch!						
It was amazing to see the actual spacecraft! I enjoyed the discussion and that teachers were able to give feedback. Looking forward to powerpoints and other resources						
Lots of thought provoking sections and data sources to use for practical applications in my HS classroom						
Great ideas to supplement several classes. More Important - Great Tools. Seeing Real Science! The sat - way cool!						
Great day, lots of good info and new ideas, thanks!!						
Time got a little mashed in the AM, maybe 1 less ppt or blend 1st 3 into 1 or 2.						
Please continue providing such awesome experiences. Include more details on the validation process for class room application please. Thank you!						
Great location for workshop						
Very interesting, well organized, excellent presenters, sometimes a little over my head. Thank you!						
My students are engaged when I present 'real' science to them. I am excited to bring this back & share with them. 4th/5th graders love to think critically & solve problems. This was great!						
Well organized. Excellent information and lessons to use in my classroom						
Need more explanation on the bands and what they do. Collaborate on who is covering what in the morning since we were over on time.						
Great PD opportunity!						
I thoroughly enjoyed the workshop! I will be using this to help recruit a steller-Xplorers team.						
Recommendations: 1) microphone for "tour guides" 2) a few short activities 3) icebreaker to start 4) If possible, have larger name tags to see names .						
Great that Steve, Larry, Mike were here and presented. I loved the VR. Thank you Margaret! Thank you Steve.						
Thanks! Amazing Opportunity.						
As an informal educator it wasn't 100% suited to my needs, but I learned a lot and can adapt to my needs.						
Also-thanks for stipend, very helpful to recognize sub of travel costs!!						

Figure 111. Evaluations from the GOES-S workshop, n=30.

## Publications and Conference Reports

Mooney, Margaret. Galvanizing educator awareness around the GOES-R satellite series with Science Teachers, Science Centers and TV Broadcasters. EUMETSAT New Generation Operational Environmental Satellites. Rome, Italy, 2-6 October 2017.





Mooney, Margaret. Galvanizing educator awareness around the GOES-R satellite series. Annual Symposium on New Generation Operational Environmental Satellite Systems, 14th, Houston, TX, 7-11 January 2018. American Meteorological Society, Boston, MA, 2018.

### **36. CIMSS Support to GOES-16 ABI Weighting Function Training for Operational Users**

**CIMSS Task Leader: Mathew Gunshor**

**CIMSS Support Scientists: Szuchia Moeller, Scott Lindstrom, Jordan Gerth**

**NOAA Collaborators: Timothy J. Schmit, Christopher Gitro (NWS)**

**Budget: \$105,399**

#### **NOAA Long Term Goals:**

- Weather-Ready Nation

#### **NOAA Strategic Goals:**

- Serve society's needs for weather and water
- Provide critical support for the NOAA mission

#### **CIMSS Research Themes:**

- Satellite Meteorology Research and Applications
- Satellite Sensors and Techniques
- Education and Outreach

#### **Objective**

The goal of this project is to educate researchers and users, including forecasters, on the topic of GOES spectral band weighting functions primarily with an enhanced, modernized website that includes more information than is currently available for GOES "realtime" weighting functions, including new satellites (GOES-16 and Himawari-8). This will allow users of GOES-16 data to better understand the data. For example, correlating changes to imagery over time with changes in moisture, temperature, and other parameters.

#### **Project Overview**

Weighting functions calculated using a fast forward radiative transfer model (RTM) are a tool forecasters and scientists can use to understand the vertical extent of a spectral band on satellite instruments such as the Advanced Baseline Imager (ABI) on GOES-16. The weighting function is a two dimensional plot which illustrates the contribution layer of the spectral band given the temperature, moisture, and ozone profile as inputs. View angle, skin temperature, and surface emissivity also contribute to the variability observed. Given that these parameters change across satellite image scene and time, weighting functions are critical to understanding what is being sensed by individual bands and can be used to compare different bands, such as the three water vapor bands on ABI for a given scene. Of particular interest to scientists, forecasters, and others is the peak pressure of the contribution, which can be used to derive a height in the atmosphere. The peak pressure, and calculated brightness temperature, can vary with temperature, moisture content, view angle, surface emissivity, skin temperature, and the presence of other absorbing gasses such as carbon dioxide, sulfur dioxide, and more.

The CIMSS GOES "Realtime" Weighting Functions webpage has been online for approximately 10 years. This page gives users the ability to view weighting functions calculated from a fast forward radiative transfer model for RAOBs at 00 and 12 UTC daily. RAOB stations include



those in CONUS, non-CONUS stations in Alaska, Hawaii, and Puerto Rico, and some South American stations. The calculations are done for both GOES-East and GOES-West and the page is updated twice a day. In addition, there are static versions of the page for the Advanced Baseline Imager (ABI), the ABI's sister instrument which is called the Advanced Himawari Imager (AHI), GOES-10, and GOES-13. These static versions allow a user to alter view angle, surface temperature, total column moisture, and between 4 standard/canned atmospheres. This website has been used for training of National Weather Service (NWS) personnel, in satellite meteorology classes and workshops both national and international, in COMET modules, and occasionally operationally by NWS forecasters.

CIMSS proposed a 3 year project to update this website, enhance its capabilities, and work toward providing this information in AWIPS. In addition to this, CIMSS personnel would include these data in NWS training, working with forecast offices to better understand the ABI, and demonstrating how the data can be used to better understand the atmosphere. Feedback from forecasters and trainers would be implemented when possible.

### **Milestones with Summary of Accomplishments and Findings**

The proposed tasks for FY16 were as follows:

1. Modernize Current Weighting Function Page, and
2. Add GOES-16 ABI to realtime page.

Both of these tasks were accomplished by the time GOES-16 transitioned to become operational GOES-East. Additionally, peak pressure of the weighting function for each band was added to the plots. The weighting function web page was highlighted at the GOES-R Short Course at the 2018 Annual AMS Meeting and one attendee stated that learning about the existence of GOES-16 realtime weighting functions was, "worth the price of admission." CIMSS personnel Jordan Gerth and Scott Lindstrom, along with NOAA/ASPB partner Tim Schmit, have held over a dozen trainings in January/February 2018 at NWS offices in Green Bay and Milwaukee, making use of the website and getting feedback on how to improve it for the forecasters. These trainings leverage other training projects and will continue throughout the year.

A change was made to the default settings of the website based on the recent NWS trainings. The trainers found themselves most often wanting to show the three ABI water vapor channels and the default view was to show all ten of the ABI IR bands. So now when a user loads a RAOB station's weighting function plots, they will start with the three water vapor bands. There have been other suggestions as well, some simple and some more complicated. Simple fixes: 1) Use temperature units of Celsius instead of Kelvin. 2) Switch total precipitable water to units of inches instead of millimeters. A more difficult suggestion to implement is that the site remember which bands have been plotted when switching between stations. All changes are on hold until the current wave of NWS trainings have passed so that there is no impact to training events.

### **Future Milestones**

#### **Year 2**

- Add Himawari-8 AHI to realtime page
- Add peak pressure of the weighting function to each plot
- Add forecast model analyses as input to fast forward model, increasing number of locations to model grid (e.g. GFS model)

#### **Year 3**

- Add forecast model times to increase times from 00 and 12 UTC to 3-hourly out to 24 hours



CIMSS will continue to respond to feedback from trainers and users on page improvements and start on Year 2 milestones in Year 1. It is anticipated that the GFS model version of this site may take significant time to implement. It is a simple enough concept, but how to best make use of these data may take time to work through. Starting in year 1 should ensure that is up and running in Year 2.

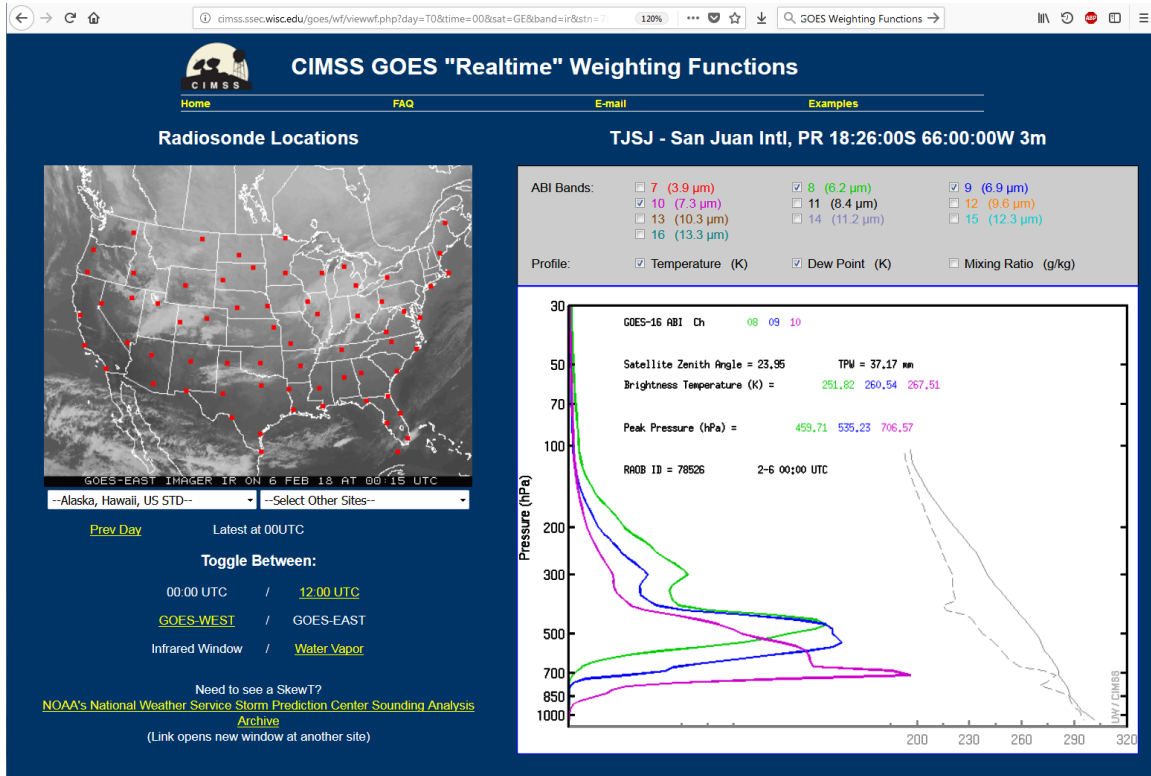

Figure 112. GOES-16 ABI water vapor band weighting functions for San Juan, Puerto Rico on February 6, 2018 at 00UTC.

### 37. GOES-R Education Proving Ground

**CIMSS Task Lead: Margaret Mooney**

**CIMSS Support Scientist: Mat Gunshor and Rick Kohrs**

**NOAA Collaborators: Tim Schmit and Steve Goodman**

**Budget: \$53,000**

#### NOAA Long Term Goals:

- Climate Adaptation and Mitigation
- Weather-Ready Nation

#### NOAA Strategic Goals:

- Serve society's needs for weather and water
- Understand climate variability and change to enhance society's ability to plan and respond

#### CIMSS Research Themes:

- Education and Outreach



## **Objective**

Promote GOES-R Satellite Series advancements to formal and informal audiences, especially grade 6-14 educators and students.

## **Project Overview**

The GOES-R Education Proving Ground (<http://cimss.ssec.wisc.edu/education/goesr/>) features the design and development of lesson plans, activities and learning opportunities for G6-14 teachers and students to ensure that the education community is “launch ready” for new satellite imagery and improved products available in the GOES-R era.

A key element of this effort is a core group of educators working with Education and Outreach staff at the Cooperative Institute for Meteorological Satellite Studies (CIMSS) in close coordination with NOAA scientists at the Advanced Satellite Products Branch (ASPB) and members of GOES-R Algorithm Working Group at CIMSS.

## **Milestones with Summary of Accomplishments and Findings**

Following the historic November 2016 launch of the GOES-R satellite, the GOES-R Education Proving Ground leveraged long-standing relationships with educators to promote GOES-16 data in 2017. This was accomplished primarily via regular emails to over 100 teachers combined with numerous posts to CIMSS social media. CIMSS also coordinated a webinar and workshop session through the Earth Science Information Partners (ESIP) Education committee and a presentation at the National Science Teachers Association (NSTA) meeting in Milwaukee Wisconsin. In addition, CIMSS organized a full day teacher workshop at Lockheed Martin in August 2017.

### ***GOES-S Teacher Workshop at Lockheed Martin***

Numerous GOES-R/GOES-16 launch delays meant many educators’ travel plans were dashed, resulting in a request to see a satellite prior to launch. As a result, CIMSS organized a teacher workshop hosted by Lockheed Martin on August 23<sup>rd</sup> featuring the GOES-S satellite! Forty educators registered and thirty attended the exciting 1-day event. For those that made it, a unique experience ensued. The full agenda with links to power-point presentations is on-line at <http://www.cimss.ssec.wisc.edu/education/goesr/GOES-S.html>. Workshop evaluations collected at the end of the day resulted in seventeen participants giving the workshop an overall rating of “excellent,” ten chose “very good” and three chose “good.” Comments collected indicated that some teachers found the science content challenging but everyone appreciated the experience. (See Figure 2 on page 26 for a group photo.)

Because of the workshop, participants received official invites to the 2018 GOES-S launch, and over a dozen attended!



Figure 113. Teachers at Kennedy Space Center just prior to the GOES-S launch.

### ***GOES-16 Movie for NOAA's Science On a Sphere® (SOS)***

The GOES-R program also requested a short movie for NOAA's Science On a Sphere (SOS) prior to the GOES-S launch featuring GOES-16 ABI data of Hurricanes Harvey, Irma and Maria. The movie is available at <https://sos.noaa.gov/datasets/goes-16-tracks-the-big-three/>.

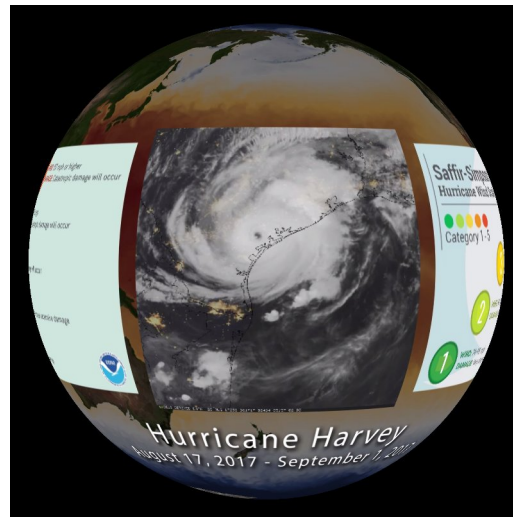

Figure 114. GOES-16 movie for NOAA Science On a Sphere (SOS).

### **Publications and Conference Reports**

Mooney, Margaret. Galvanizing educator awareness around the GOES-R satellite series with Science Teachers, Science Centers and TV Broadcasters. EUMETSAT New Generation Operational Environmental Satellites. Rome, Italy, 2-6 October 2017.

Mooney, Margaret. Galvanizing educator awareness around the GOES-R satellite series. Annual Symposium on New Generation Operational Environmental Satellite Systems, 14th, Houston, TX, 7-11 January 2018. American Meteorological Society, Boston, MA, 2018.



### **38. ABI Short Courses (CIMSS Support to the GOES-R Program)**

**CIMSS Task Leader: Mathew M. Gunshor**

**CIMSS Support Scientists: Scott Lindstrom, Jordan Gerth, Chris Schmidt**

**NOAA Collaborator: Timothy J. Schmit**

**Budget: \$52,000**

#### **NOAA Long Term Goals:**

- Weather-Ready Nation

#### **NOAA Strategic Goals:**

- Serve society's needs for weather and water
- Provide critical support for the NOAA mission

#### **CIMSS Research Themes:**

- Education and Outreach

#### **Objective**

Present day-long short courses to introduce the GOES-R series primarily at conferences, such as the AMS annual and broadcast meteorology conferences.

#### **Project Overview**

This report is for the final year of a project that spanned 3-years for CIMSS to support the GOES-R program's plan to attend multiple American Meteorological Society (AMS), and other, conferences to provide training on uses of GOES-R, primarily the Advanced Baseline Imager (ABI). This year CIMSS supported GOES-R short courses at the AMS 45th Conference on Broadcast Meteorology (in Kansas City, MO), the 42<sup>nd</sup> Annual National Weather Association meeting (in Garden Grove, CA), and the 98th AMS Annual Meeting (in Austin, TX). In preparation for each short course, the instructors prepare presentations and engaging hands-on material to present to the students. Whenever possible, material is tailored to the audience. While AMS annual meetings have a fairly general meteorological audience, others such as a broadcaster meeting have audiences with a more specific focus. Presentations are also tailored for region and the instructors try to make use of case studies that are recent and had a local impact when possible. At some conferences GOES-R and JPSS Programs combine efforts and a joint short course is held, as was the case at the 2017 NWA Annual Meeting.

#### **Milestones with Summary of Accomplishments and Findings**

- Helped to organize and presented GOES-R Short Courses:
  - June 20, 2017 preceding the AMS 45th Conference on Broadcast Meteorology in Kansas City, MO.
  - September 16, 2017 at the 42<sup>nd</sup> Annual National Weather Association (NWA) Meeting in Garden Grove, CA.
  - January 6, 2018 preceding the 98<sup>th</sup> AMS Annual Meeting in Austin, TX
- Typical preparation for a short course includes:
  - Preparing hands-on and presentation material that includes audience-specific (or site-specific) case studies with recent data.
  - Inviting and/or coordinating with a lunch-time speaker.
  - Setting up a course web site so participants have easy access to hands-on web app material and can later download presentations.
- During a short course:



- Presenting an introduction to The GOES-R Advanced Baseline Imager (ABI): Capabilities, products, and concept of operations
- Hands-on exercises showcasing ABI's 16 channels with improved spatial resolution, temporal refresh rate, and RGB products.
- Hands-on exercises highlighting GOES-R derived products used in the Proving Ground
- Hands-on exercises using operational GOES-R derived products.



Figure 115. Mat Gunshor of CIMSS presenting at the GOES-R Short Course in Kansas City for the AMS Conference on Broadcast Meteorology..

## 39. CIMSS Research Activities in the VISIT program in 2017-2018

### 39.1 CIMSS Support for Satellite Training Activities for the VISIT Program

**CIMSS Task Leader: Scott Lindstrom**

**CIMSS Support Scientist: Scott Bachmeier**

**NOAA Collaborator: Tim Schmit, Bill Ward, Brian Motta, Ross van Til**

**Budget: \$164,000**

#### **NOAA Long Term Goals:**

- Weather-Ready Nation

#### **NOAA Strategic Goals:**

- Serve society's needs for weather and water
- Provide critical support for the NOAA mission

#### **CIMSS Research Themes:**

- Satellite Meteorology Research and Applications
- Satellite Sensors and Techniques
- Education and Outreach

#### **Objective**

VISIT (Virtual Institute for Satellite Integration Training) work at CIMSS focused in 2017-2018 on the development of two-page Quick Guides and short Quick Brief training modules to improve forecaster knowledge of satellite capabilities.

#### **Project Overview**

VISIT supported training activities designed to champion the used of Satellite Data in National Weather Service forecast offices. In 2017-2018, this included the development of almost 30 2-page Quick Guides that can be accessed via AWIPS and are stored in the VLab. In addition, 5



recorded Quick Briefs that described ABI Channel Differences that are available in AWIPS were created. VISIT supported Live teletraining to individual forecast offices on recently-developed satellite-focused training modules. VISIT supported “FDTD GOES-16” webinars in which primarily NWS Science and Operations Offices (SOOs) described local uses of GOES-16 imagery.

### **Milestones with Summary of Accomplishments and Findings**

VISIT support led to the creation of 2-page Quick Guides on all 16 ABI Channels; on the Channel Difference fields that are available in AWIPS (that is, 10.3 – 3.9; 10.3 – 12.3; 6.19 – 7.34; 8.5 – 11.2); on Baseline Products (Clear Sky Mask, Cloud Top Products, Derived Stability Indices, Legacy Atmospheric Profiles, Fire Products, Aerosol Detection, Derived Motion Winds, among others). This work is ongoing and is expanding to include Suomi NPP/NOAA-20 Products (for example, NUCAPS Soundings). GOES-16 Quick Guides developed at CIMSS are at [this link](http://cimss.ssec.wisc.edu/goes/GOESR_QuickGuides.html). ([http://cimss.ssec.wisc.edu/goes/GOESR\\_QuickGuides.html](http://cimss.ssec.wisc.edu/goes/GOESR_QuickGuides.html))

VISIT support also led to the creation of short (about 5-minute length) “Quick Brief” training videos on Channel Difference fields in AWIPS.

VISIT also supported multiple live teletrainings (using VISITview software) to National Weather Service Forecast Offices on the following topics: “NOAA/CIMSS ProbSevere”, “GOES-R Fog/Low Stratus Products”, “NUCAPS Soundings in AWIPS”, “Mesoscale Convective Vortices”, “TROWAL Identification”, and in person one-day training events to the National Weather Service offices in Sullivan and Green Bay WI.

VISIT supported the updating of the “GOES-R Fog/Low Stratus Product” training module to include GOES-16 Imagery.

VISIT supported CIMSS’s participation in the FDTD GOES-16 Webinars. This participation was principally on the back end, helping SOO presenters to get their presentation into the proper format.



**Derived Stability Indices Quick Guide**

**Why are Derived Stability Indices Important?**

Stability Indices can diagnose where convection might occur. The indices, especially their gradients and time tendencies, can give important information in the pre-convective environment. Five different stability indices are available: Total Totals, K, Showalter and Lifted Indices, and Convective Available Potential Energy (CAPE).

**Derived Stability Index Requirements**

Domain	Temporal Refresh	Horizontal Resolution
Full Disk	Every 15 minutes	10 km
CONUS	Every 5 minutes	
Mesoscale	Every 1 minutes	

**Impact on Operations**

**Primary Application:** Diagnose where convection is likely to occur. Monitor destabilization in the atmosphere and identify gradients in stability along which convection might form.

**Application:** Some of these products can also tell you where the atmosphere is most stable.

**Definition:** CAPE and Lifted Index are computed using a mixed-layer parcel from the lowest 100 hPa in the atmosphere.

**Limitations**

**Clear-sky only application:** This is a clear-sky only product.

**Limitation:** The products are created by taking the GFS thermodynamic fields and adjusting them based on satellite observations of temperature and moisture. Satellite moisture observations have the biggest impact in the middle troposphere.

**Limitation:** The products have 10-km resolution vs. the 2-km resolution of ABI infrared channels.

Contributor: Scott Lindstrom, UW CIMSS  
Revision Date: March 2018

Figure 116. First page of Derived Stability Indices Quick Guide.

### Publications and Conference Reports

Schmit, T. J., S. S. Lindstrom, J. J. Gerth and M. M. Gunshor, 2018: **Operational Applications of the 16 Spectral Bands on the Advanced Baseline Imager (ABI)**. *J. Operational Meteor.* (Accepted, in press)

Lindstrom, S. S., A. S. Bachmeier and T. J. Schmit, 2018: **Communicating new Satellite Technologies through the use of Blog**. 27<sup>th</sup> Symposium on Education, 98<sup>th</sup> Annual Meeting of the American Meteorological Society, 7-11 January 2018, Austin, TX.

Lindstrom, S. S., J. J. Gerth, D. Hoese and R. Garcia, 2018: **Using the Satellite Information Familiarization Tool (SIFT) to Train on New Multi-Spectral Geostationary Satellite Sensors**. 34<sup>th</sup> Conference on Environmental Information Processing Technology and 98<sup>th</sup> Annual Meeting of the American Meteorological Society, 7-11 January 2018, Austin TX.

Lindstrom, S. S., A. S. Bachmeier, J. J. Gerth, T. J. Schmit, M. M. Gunshor, D. Bikos, E. J. Szoke and B. H. Connell, 2018: **VISIT and SHyMet Training Activities at CIMSS**. 14<sup>th</sup> Annual



Symposium [on New Generation Operational Environmental Satellite Systems](#) and 98<sup>th</sup> Annual Meeting of the American Meteorological Society, 7-11 January 2018, Austin, TX.

Li, J., J. Gerth, Y.-K. Lee, Z. Li, T. J. Schmit, P. Wang and S. Lindstrom, 2018: **All-Sky Layered Precipitable Water Products from ABI/AHI and Their Applications in Nowcasting and Forecasting the Severe Storms**, 14<sup>th</sup> Annual Symposium on New Generation of Operational Environmental Satellite Systems and 98<sup>th</sup> Annual Meeting of the American Meteorological Society, 7-11 August 2018, Austin TX.

Wimmers, A., S. M. Griffin, A. S. Bachmeier, J. J. Gerth and S. S. Lindstrom, 2018: **Resolving Gravity Waves with Himawari-8 and GOES-16 Imagery at the New Limit of Resolution and the Application to Aircraft-Scale Turbulence**, [Sixth Aviation, Range, and Aerospace Meteorology Special Symposium](#) and 98<sup>th</sup> Annual Meeting of the American Meteorological Society, 7-11 August 2018, Austin TX.

Jasmin, T., S. S. Lindstrom, A. S. Bachmeier and T. T. Whittaker 2018: **VISITview: 20 Years of Forecaster Training and Counting**. 34<sup>th</sup> Conference on Environmental Information Processing Technology (EIPT) and 98<sup>th</sup> Annual Meeting of the American Meteorological Society, 7-11 August 2018, Austin TX.

Ward, B., [F. Alsheimer](#), [B.C. Carcione](#), [C. B. Entwistle](#), R. D. Ewald, M. T. Stavish, G. T. Stano, K. W. Mozer, J. J. Gerth, S. S. Lindstrom, T. J. Schmit, C. M. Gravelle, K. J. Runk, M. A. Bowlan, J. G. LaDue, J. E. Ogren, E. J. Szoke, D. Bikos, 2018: **Workshops on GOES-16 Data for National Weather Service SOOs and DOHs**. [14th Annual Symposium on New Generation Operational Environmental Satellite Systems](#) and 98<sup>th</sup> Annual Meeting of the American Meteorological Society, 7-11 January 2018, Austin TX.

Lindstrom, S., T. J. Schmit, M. Gunshor, J. Daniels, K. Bah and S. J. Goodman, 2017: **Latest Assessment of GOES-R (16) Advanced Baseline Imager (ABI) Data Quality from an Application and Training Perspective**, IGARSS 2017, Fort Worth, TX, M03.L8.

### **39.2 CIMSS Support to Develop of the Satellite Information Familiarization Tool to Support the National Weather Service Training Program**

**CIMSS Task Leader: Jordan Gerth**

**CIMSS Support Scientists: Ray Garcia, Dave Hoese, and Scott Lindstrom**

**NOAA Collaborators: Tim Schmit, National Environmental Satellite, Data, and Information Service Advanced Satellite Products Branch; and Bill Ward, National Weather Service Pacific Region Headquarters**

**Budget: \$77,000**

#### **NOAA Long Term Goals:**

- Weather-Ready Nation

#### **NOAA Strategic Goals:**

- Serve society's needs for weather and water
- Provide critical support for the NOAA mission

#### **CIMSS Research Themes:**

- Satellite Meteorology Research and Applications



- Education and Outreach

### **Objective**

This project continues the development of the Satellite Information Familiarization Tool (SIFT), open-source software that is freely available and used primarily by the National Weather Service (NWS) for training and post-event geostationary satellite data review. Releases and new features align with the NWS operational meteorologist training program.

### **Project Overview**

The Satellite Information Familiarization Tool, or SIFT, is a meteorological satellite imagery visualization software application with a graphical user interface designed at the University of Wisconsin to run on mid-range consumer grade computers and notebooks. Windows, Mac, and some Linux operating systems are supported. SIFT is open source and freely available. The National Weather Service (NWS) originally funded the development of SIFT for use as a training application for Himawari-8 imagery at the forecast offices in Guam and Honolulu, but SIFT's capabilities have expanded to handle imagery from the Geostationary Operational Environmental Satellite R-Series (GOES-R) Advanced Baseline Imager (ABI).

SIFT is the primary learning software for the foundational and applications training exercises on the new-generation geostationary weather satellites as part of the formal NWS training program. SIFT, used during seven preparatory courses offered to nearly all NWS Science and Operations Officers (SOOs) on the GOES-R in late 2016 and early 2017, is familiar to the NWS and actively used for the review of meteorological satellite data following events.

### **Milestones with Summary of Accomplishments and Findings**

The current release of SIFT is version 0.9.4. Current capabilities of SIFT allow users to: visualize Himawari-8 Advanced Himawari Imager (AHI) and GOES-R ABI imagery at full bit depth, loop through multiple bands for a single time, or multiple times for a single band; change the color enhancement by band; control the color-value mapping for each enhancement; seamlessly pan and zoom across entire full disk images, even while looping; probe a point/pixel to determine the reflectance or brightness temperature for all loaded bands at that location; produce Red-Green-Blue (RGB) spectral or time composites; create histograms (single band) and density maps (two bands) based on a user-defined polygon on an image; save images and animations; and perform basic arithmetic involving spectral bands captured at the same time. An example of the SIFT graphical user interface (GUI) is shown in Figure 117.

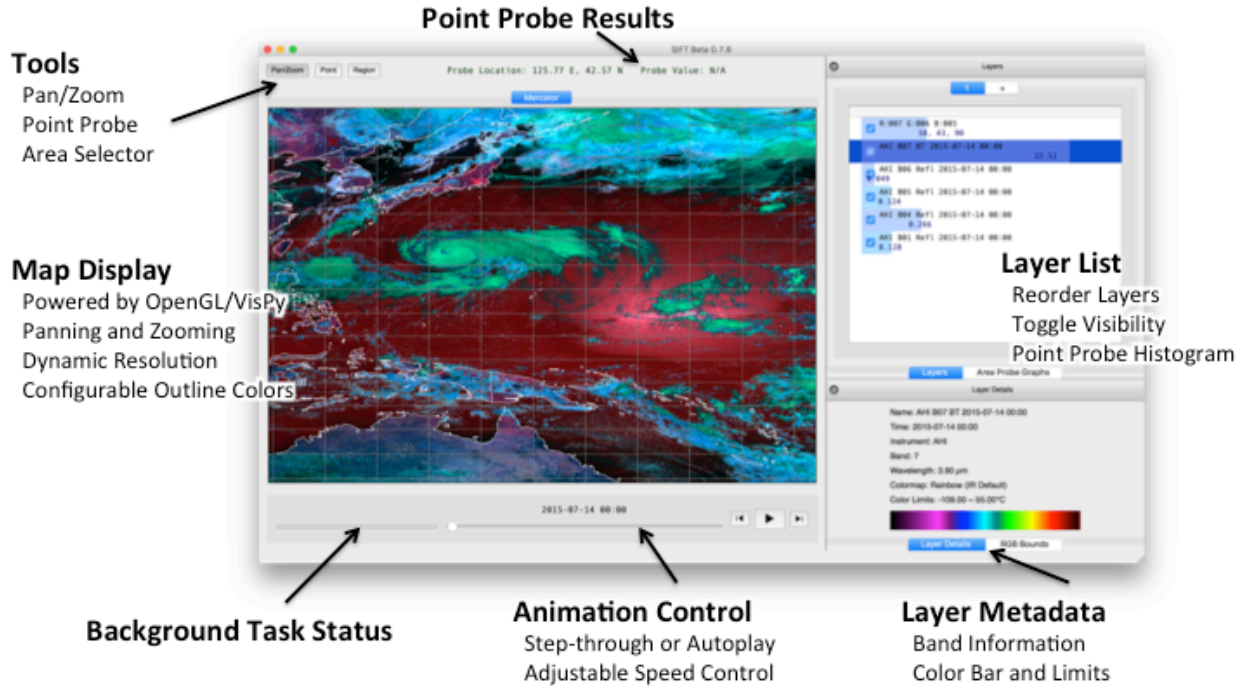

**Figure 117.** This SIFT screen capture shows the graphical user interface (GUI) with annotated capabilities: tools, point probe results, layer list, layer metadata, animation control, background task status, and map display.

SIFT was designed to maximize performance and nearly eliminate crashes. It reads common data formats with geospatial information (GeoTIFF and NetCDF), characteristic of satellite imagery. The release of version 1.0.0 is in preparation and due out in 2018 with additional features and performance improvements.

The SIFT developers were able to resolve approximately 30 support tickets in the year preceding 1 April 2018, at which time there were 44 open support tickets that address discrepancies (i.e., “bugs”), enhancements, and optimizations of varying priority. As part of the testing procedure for SIFT, alpha and beta releases incorporating discrepancy fixes, new enhancements, and optimized code are made available online prior to the announcement of a new formal release.

In addition to development activities, this project provides assistance to NWS SOOs, NWS training divisions, and funded partners who have incorporated SIFT, or plan to, into training exercises so that there is no degradation in user experience. CIMSS works closely with the NWS to ensure SIFT ably functions on NWS hardware of sufficient grade. CIMSS maintains a web site for all users to download the software and learn how to retrieve data (<http://sift.ssec.wisc.edu/>).

SIFT was used in one training event during the reporting period, at the NOAA Satellite Conference in New York City, New York, in July 2018. SIFT was also presented as an easy-to-use tool capable of displaying and interrogating geostationary satellite imagery during the GOES-R/16 workshops conducted with NWS assistance in Argentina and Chile during late November and December 2018. SIFT has both operational and scientific users. SIFT has been introduced to attendees at annual meetings of the American Meteorological Society (AMS) and National Weather Association (NWA).



## **Publications and Conference Reports**

Lindstrom, S. S., J. J. Gerth, D. Hoese and R. Garcia, 2018: *Using the Satellite Information Familiarization Tool (SIFT) to Train on New Multi-Spectral Geostationary Satellite Sensors*. 34th Conference on Environmental Information Processing Technology (EIPT) and 98th Annual Meeting of the American Meteorological Society (AMS), Austin, Texas, 11 January 2018. Oral presentation.

Lindstrom, S. S., 2017: *Red Green Blue (RGB) Composites with GOES-16 Data*. Environment Canada (EC) Train the Trainer Workshop, Montreal, Quebec, Canada, 25 October 2017. Oral presentation via WebEx. This presentation contained examples of SIFT.

## **40. CIMSS Support for GOES-R ABI Trainings (CIMSS Support to GOES-R Program)**

**CIMSS Task Leader: Mathew M. Gunshor**

**CIMSS Support Scientists: Jordan Gerth, Scott Lindstrom, Chris Schmidt**

**NOAA Collaborator: Timothy J. Schmit**

**Budget: \$120,000**

### **NOAA Long Term Goals:**

- Weather-Ready Nation

### **NOAA Strategic Goals:**

- Serve society's needs for weather and water
- Provide critical support for the NOAA mission

### **CIMSS Research Themes:**

- Education and Outreach

### **Objective**

The primary objective of this project is to provide support to the GOES-R Program's training efforts to reach a wide audience of users, including international users.

### **Project Overview**

This project is in the first of a 2-year plan for CIMSS to support the GOES-R program's efforts to provide training on uses of the GOES-R series Advanced Baseline Imager (ABI). The first year CIMSS proposed to attend the Canadian Meteorological and Oceanographic Society's (CMOS) 51st Congress in Toronto, Canada, the 8th Asia/Oceania Meteorological Satellite Users' Conference (AMOSUC) in Vladivostok, Russia, and the NOAA Satellite Conference in New York, NY. CIMSS personnel were requested to attend and provide training by the GOES-R program at these three events. The planned training at AMOSUC fell through and no GOES-R training was conducted at that meeting. This project covers some of the preparation time and the travel for two-three attendees at each event.

### **Milestones with Summary of Accomplishments and Findings**

- Helped to organize and presented GOES-R Training Workshops:
  - June 04, 2017 at the Canadian Meteorological and Oceanographic Society (CMOS) 2017 Congress
  - July 16 & 18, 2017 at the NOAA Satellite Conference (NSC) in New York, NY.



This project is able to leverage the efforts of other training projects at CIMSS, especially the experience of the GOES-R Short Courses. The preparation for a workshop is similar to that of a short course and includes the preparation and organization of hands-on and presentation material that is audience-specific, site-specific, and includes recent case studies. CIMSS personnel work with other GOES-R (and sometimes JPSS) scientists ahead of the workshop to prepare an agenda that fits the needs of the host organization. Typically the parts of a workshop CIMSS is responsible for include an introduction to the GOES-R Advanced Baseline Imager (ABI): Capabilities, products, and concept of operations, hands-on exercises showcasing ABI's 16 channels with improved spatial resolution, temporal refresh rate, and RGB products. Hands-on exercises highlighting GOES-R derived products will also be presented, with the products typically chosen for the specific audience.

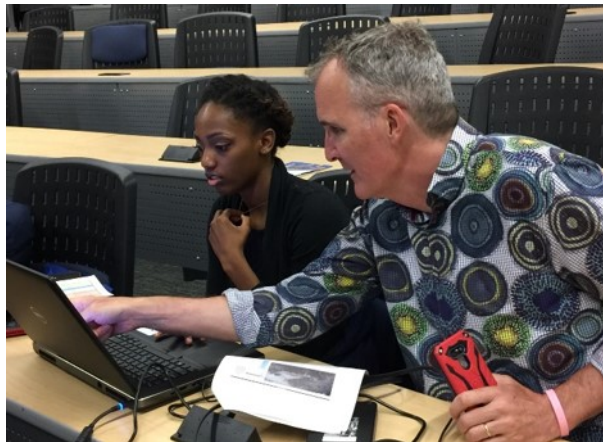

**Figure 118. Scott Lindstrom (right) of CIMSS instructing a student during a hands-on exercise at a GOES-R workshop.**



## Appendix 1: List of Awards to Staff Members

### 2018

**Margaret Mooney:** UW-Madison Robert and Carroll Heideman Award for Excellence in Public Service and Outreach

**Chris Velden:** American Meteorological Society Banner I. Miller Award

### 2017

#### **SSEC/CIMSS:**

GOES-R Team Award

NASA 2017 Agency Honor Award

Group Achievement Award

**Steven Ackerman:** New Library World Highly Commended Award

**Eva Borbas:** ITSC-21 Gold for Best Poster Presentation

**Burcu Kabatas:** Best Dissertation Award, Istanbul Technical University

**Jim Kossin:** NESDIS Award for Outstanding Science & Data Management

**Jim Kossin:** AMS Editor's Award

**Zhenglong Li:** ITSC-21 Bronze for Third Best Poster Presentation

**Margaret Mooney:** New Library World Highly Commended Award

**Hank Revercomb:**

Fellow of the AMS, for “outstanding contributions to advance the atmospheric and related sciences, technologies, applications”

ITSC-21 Gold for Best Oral Presentation

**Tim Schmit:**

NOAA Administrator's and Technology Transfer Award

NOAA Administrator's Award

**William Straka III:** JPSS Program Office Extra Mile Award

**David Tobin:** 2017 Chancellor's Award for Excellence in Research

**Pei Wang:** The Chinese-American Oceanic and Atmospheric Association Dissertation Award



## Appendix 2: Publications Summary

**Table 1** below indicates the number of reviewed and non-reviewed papers that include a CIMSS or ASPB scientist as first author during the period 2015-2017. Two additional columns show lead authorship of NOAA scientists outside of ASPB or lead authors from other institutions or organizations. When summed, peer reviewed totals for each year (in Table 1) will equal peer reviewed totals in Table 3, a longitudinal graphic.

**Table 2** below shows collaborations on papers between or among Institute, ASPB, and NOAA authors outside of ASPB. Because there may be many collaborators on a given paper, the by-year totals in Table 2 will not match the actual published paper totals in Table 1 (or in Table 3); they will be greater.

A bibliography of Advanced Satellite Products Branch (ASPB) publications is available at: [http://library.ssec.wisc.edu/research\\_Resources/bibliographies/aspb](http://library.ssec.wisc.edu/research_Resources/bibliographies/aspb)

**Table 1.** Totals of Peer Reviewed and Non Peer Reviewed journal articles having CIMSS, ASPB, NOAA, or Other lead authors, 2015-2017.

	Inst Lead			ASPB Lead			NOAA Lead			Other Lead		
	2015	2016	2017	2015	2016	2017	2015	2016	2017	2015	2016	2017
<b>Peer Reviewed</b>	20	30	21	4	2	2	10	13	5	50	37	44
<b>Non Peer Reviewed</b>	0	0	0	0	0	0	0	0	1	0	0	1

**Table 2.** Peer Reviewed and Non Peer Reviewed journal articles having one or more CIMSS, ASPB, or NOAA co-authors, 2015-2017.

	Institute Co-Author			ASPB Co-Author			NOAA Co-Author		
	2015	2016	2017	2015	2016	2017	2015	2016	2017
<b>Peer Reviewed</b>	99	121	94	27	24	20	64	54	31
<b>Non Peer Reviewed</b>	0	0	5	0	0	0	0	0	0





**Table 3.** CIMSS Publishing History, showing peer reviewed and conference publications for the period 1995-2017.

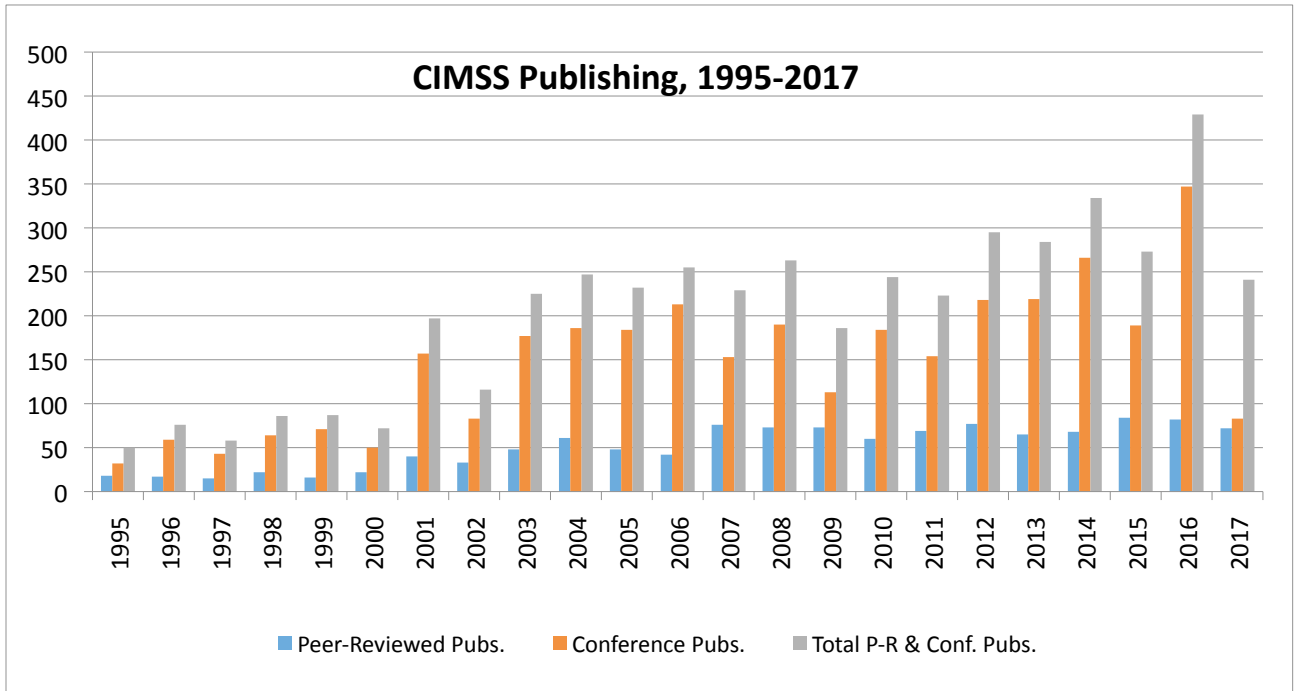



### Appendix 3: Employee Support Documentation

Personnel				
Category	Number	B.S.	M.S.	Ph.D.
Research Scientist	10	0	1	9
Visiting Scientist	0	0	0	0
Postdoctoral Fellow	0	0	0	0
Research Support Staff	38	3	27	8
Administrative	0	0	0	0
<b>Total</b> (≥ 50% Support)	48	3	28	17
Undergraduate Students	14			
Graduate Students	6	4	2	
Employees that received <50% NOAA Funding (not including students)	69	13	26	26
Located at Lab (include name of lab)	1 - JCSDA			
Obtained NOAA employment within the last year	0			



## Appendix 4: Research Topics of Current CIMSS Graduate Students and Post-Doctors

### NOAA Funded Graduate Students

#### *Margaret Bruckner*

This research focuses on the use of indirect validation of Ozone Mapping Profiler Suite (OMPS) limb retrievals, extension of the Real-time Air Quality Modeling System (RAQMS) chemical re-analysis to include OMPS, and use of the extended re-analysis to investigate both ozone interannual variability and trends associated with the ozone recovery. Datasets being used indirect validation include ozonesondes and infrared ozone retrievals from the Atmospheric Chemistry Experiment (ACE). Indirect validation does not require coincident measurements, which increases the number of data points included in the intercomparison of datasets and reduces the error in comparing the datasets.

#### *Alexander Goldstein*

Ph.D. research focus: Formulation and time-evolution of adjoint-derived quasi-optimal iterative perturbations (QOIP) made to the initial-model (analysis) state aimed at modulating the intensification rate of a mid-latitude cyclone. Multiple previous studies have examined the impact of adjoint-derived perturbations upon the intensity of cyclones at static points in the forecast trajectory. The mathematical formulation of the response functions described in this research however allow for a time-dependence to be “built in” to the perturbations that are calculated, allowing for the augmentation of the time-rate-of-change of intensity of the cyclone within the forecast trajectory over a specified time window. With this in mind, the modulation of a modestly deepening mid-latitude cyclone into one that deepens more (less) rapidly is examined within a so-called “perturbation-response” framework, in which small perturbations to the analysis state and the atmospheric response to those perturbations are considered.

#### *Coda Phillips*

The High Spectral Resolution Lidar (HSRL) was developed at SSEC and has the capability to make precise measurements of aerosols and clouds. Research concerns the data collected by an HSRL located in Seoul, Korea where particulate matter is a significant public health concern. A large volume of research has been conducted using column-measurements of aerosol properties and surface particulate matter. As a result, little is known about vertical distribution or transport. Through fusion of the HSRL data with geostationary imagery and AERONET measurements, the intention is to observe the properties and evolution of aerosol plumes and their influences on the surface.

#### *Charles White*

MS Title: "Refining Long-Term Analysis of AVHRR Great Lakes Surface Temperatures" The Advanced Very High Resolution Radiometer (AVHRR) satellite record has long been used to measure surface temperatures over the Laurentian Great Lakes, but long-term spatiotemporal analyses are scarce. Reprocessing of the Pathfinder Atmospheres-Extended (PATMOS-x) AVHRR dataset facilitates a fine-scale spatial and temporal analysis of lake surface temperature. The results show a large range in warming rates both within and between lakes. Additionally, development of an upwelling identification algorithm will assess the frequency and duration of



major hydrodynamic episodes. By accounting for both long-term trends and episodic events, our analyses offer insight into the shifting thermal dynamics of these irreplaceable inland seas.

***Skylar S. Williams***

M.S. Title: “Validation of Water Vapor Measurements from Commercial Aircraft across the CONUS using Radiosondes.” With the addition of the Water Vapor Sensing System II (WVSS-II) on a number of commercial aircraft, water vapor measurements are added to the already present measurements of pressure, temperature, and wind. This allows for a full thermodynamic profile to be created whenever WVSS-II equipped aircraft take off and land, becoming a way to fill the spatial and temporal gaps present within upper air observations. Radiosonde-based validation of the WVSS-II has been limited to short-term field studies in climatologically similar regions, which limits understanding of its performance in different environments. In the present study, the WVSS-II is compared to operational NWS radiosondes throughout the continental United States, enabling sensor validation in all seasons and multiple climate regimes. Locational and seasonal biases are explored, and the performance of the sensor in both high and low water vapor environments is determined. Characterizing potential biases in the WVSS-II dataset will improve data assimilation processes of this data into numerical weather prediction models and create confidence for both governmental and aviation forecasters regardless of location or time of year.

***Feng Zhu***

Ph.D. research topic is high temporal resolution geostationary satellite data assimilation for tropical storms, aiming at better utilizing the satellite observations to improve the forecast of tropical storms. A portion of the research is evaluating and quantifying the impact of potential high temporal resolution geostationary satellite data sets on tropical cyclone (TC) forecasting with the method of observation system simulation experiments (OSSE). Also working on development of a new method of tropical cyclone relocation will improve the initialization of TC and, meanwhile, evaluate the impact of relocation on satellite data assimilation. Additionally, an independent research topic regarding the atmospheric system as a dynamical system, investigating the relationship between initial error, model error, and forecast error from both theoretical and practical sides. Conducting ideal experiments with toy models such as Lorenz63 and Lorenz96, and realistic experiments with WRF/GSI system, with the method of data assimilation and OSSE.

**Students Funded on other projects than NOAA**

***Kai-Wei Chang***

Ph.D. Thesis: “Processes and features of temperature, water vapor, and cirrus clouds in the tropical tropopause layer” The tropical tropopause layer controls the amount of water vapor entering the lower stratosphere. It is recognized that as air encounters cold temperatures at the tropical tropopause it is dehydrated by cirrus formation. This research explores the processes, such as tropical convection and equatorial wave dynamics that modulate temperature and water vapor at the tropopause, as well as the relation of water vapor to cirrus cloud properties observed by satellites.

***Alyson Douglas***

Environmental Effects on Precipitation Suppression in Warm Clouds” Using collocated NASA A-Train satellite observations, the effects of the environment on modulating precipitation suppression due to aerosols is analyzed in marine warm clouds. The relative humidity of the free



atmosphere plays a role in heightening or diminishing the response, depending on whether the free atmosphere is moist or dry. These effects are further analyzed with the Wisconsin Algorithm for Latent heating and Rainfall Using Satellites (WALRUS) product to examine the effects of aerosol and the environment on the latent heating and vertical motion profiles of warm clouds.

***Andrew Dzambo***

Research topic: As part of our contribution to the Observations of Aerosols above Clouds and their interactions (ORACLES) experiment, W-band radar data collected from the Advanced Precipitation Radar - 3rd Generation (APR-3) is utilized to assess stratocumulus cloud properties and structure over the SE Atlantic Ocean. Additionally, this data is further utilized in an adapted version of CloudSat's 2C-RAIN-PROFILE algorithm to retrieve precipitation rate from each (valid) W-band radar profile taken during the experiment.

***David Loveless***

Ph.D. topic: "Ground-based and Space-based Hyperspectral Infrared Sounding." The goal of this work is to develop a thermodynamic retrieval method that uses radiance measurements from both space-based and ground-based hyperspectral infrared instruments. Observations of the planetary boundary layer have been highlighted as a current need in today's earth observing system and space-based sounders lack the desired vertical resolution in the boundary layer. It is expected that by combining the Atmospheric Emitted Radiance Interferometer (AERI), a ground-based hyperspectral infrared instrument, with the space-based instruments into a single retrieval method that the accuracy of the retrieved variables will be improved and uncertainties will be decreased as compared to retrievals using only a single instrument..

***Astin Massie***

M.S. Thesis: "Developing an algorithm for retrieving ice cloud properties from AIRS, MODIS, CloudSat, and CALIPSO observations" Research involves improving the retrieval of ice cloud properties from space and working on development of an algorithm for estimating ice cloud properties (particle size, optical thickness, height, etc.) from the combined measurements of multiple satellites in the A-Train.

***Elin McIlhattan***

Ph.D. focus: "Polar Cloud Behavior and Impact on Surface Energy Balance" This research leverages measurements made by instruments aboard the NASA A-Train satellite constellation to analyze spatial and temporal distributions of polar clouds and their characteristics. Of particular interest are supercooled liquid containing clouds and their large impact on the surface radiation balance relative to fully glaciated clouds. Results of our observational analysis are used to develop benchmarks for evaluating the representation of polar clouds in global climate models. This work is supported by a NASA Earth and Space Science Fellowship.

***Jacob Miller***

M.S. research topic: This research is looking at the temporal and spatial extent of Arctic Leads, located north of Alaska. This is done by using MODIS retrieved data in an algorithm to detect the cloud cover, and find open "windows" with no clouds. In these windows another algorithm determines the coverage of ice and the orientation and width of leads based off a 95% threshold, which is then mapped, and later to be projected back on to a common grid. Currently the research involves case studies covering the time from Feb-April on selected years, in order to further improve/test the algorithms and research hypothesis.



***Ethan Nelson***

Ph.D. thesis: “Warm Rain Microphysical Processes” We are in the process of analyzing how environmental conditions affect the microphysical processes of warm rain formation and dissipation. This information comes from an algorithm that retrieves latent heating using space-borne radar vertical profiles. Our analysis will also be extended to examination of warm rain processes in the Madden-Julian Oscillation incipient stages.

***Julie Pilewskie***

M.S. research title: "Convective Clouds Influence on Water Cycle and Global Radiation Budget" The main idea for this research is to understand how local thermodynamic controls influence the relationship between the water cycle and radiative impacts of convection. We are using high-resolution CloudSat and PATMOS merged data sets, with CloudSat providing vertical profiles and PATMOS contributing temporally and spatially. With these data sets, we can accurately partition precipitating (stratiform and convective) regions from anvil regions, and then look at the cloud radiative effect to locate regions of negative and positive forcing around convective cores. Currently working on distinguishing convective properties in a storm evolving over nine hours using PATMOS data, and then comparing it to a corresponding CloudSat vertical slice.

***Julia Shates***

M.S. title: “Snowfall properties at high latitude sites” Using remote sensing observations for two high latitude sites: Haukeliseter, Norway and Kiruna, Sweden for this research. In order to characterize the snowfall in these regions, data will be used from a ground-based radar (24 GHz Micro Rain Radar), a particle imaging tool (PIP), and meteorological measurements such as wind speed and direction. Snowfall regimes will be characterized based on wind climatology and the microphysical properties of the snowflakes during precipitation events. The snowfall regimes will allow the determination of precipitation rates and improve snow accumulation estimates.

***Anne Sledd***

M.S. title: “Effects of surface cover variability on Arctic energy balance using the Arctic Observations and Reanalysis Integrated System” This research explores the interaction between clouds and surface cover in the Arctic energy budget. So far we have focused on shortwave fluxes from by partitioning the planetary albedo and investigating how the contributions are related to planetary and surface albedo as well as how they change based on surface and cloud cover. Further comparisons are made between satellite observations and reanalyses to see how well the latter perform.

***Joshua Weber***

M.S topic: “A New CloudSat Rainfall Retrieval Algorithm over Land Using a Collocated MRMS-CloudSat Dataset and a Bayesian Framework”. There is still no operational CloudSat rainfall retrieval product over land. My research hopes to show that a Bayesian approach applied to CloudSat mean reflectivity profiles for various rain rates can retrieve precipitation estimates over land.



## Appendix 5: Visitors at CIMSS 2015-2016 (visits of 3 days or more and key visitors)

<b>Patrina Bly</b>	Hampton University
<b>Monica Bozeman</b>	Meteorologist, Technology & Science Branch, NOAA/NWS/National Hurricane Center
<b>Steve Buckner</b>	Hampton University
<b>Harry Cikanek</b>	Director of STAR, NOAA/NESDIS
<b>Michael Clark</b>	Office of Management and Budget
<b>John Crockett</b>	NWS Office of Science and Technology Integration
<b>Maj. Brian DeCicco</b>	Joint Typhoon Warning Center (JTWC), DoD
<b>Cathy Finley</b>	St. Louis University
<b>John Gagan</b>	NOAA/NWS-Sullivan SOO
<b>Donatello Gallucci</b>	Institute of Methodologies for Environmental Analysis, Italian National Research Council
<b>Steve Goodman</b>	GOES-R Program Senior Scientist
<b>Jung-Sun Im</b>	NWS Office of Science and Technology Integration
<b>Satya Kalluri</b>	Chief of CoRP, NOAA/NESDIS/STAR
<b>Sean Leavor</b>	Hampton University
<b>Jung-Rim Lee</b>	Korea Meteorological Administration
<b>Yu-Ching Liu</b>	Central Weather Bureau
<b>Bing Lu</b>	Institute of Urban Meteorology of China Meteorology Administration
<b>Linda Luu</b>	Taiwanese Central Weather Bureau
<b>Qingqing Lyu Administration</b>	National Satellite Meteorology Center, Chinese Meteorological
<b>Leon Majewski</b>	Australian Bureau of Meteorology
<b>John Murphy</b>	NOAA/NWS Chief Operating Officer
<b>Matyas Rada Hungary</b>	Institute of Geodesy, Cartography and Remote Sensing, Budapest,
<b>Aku Riihela</b>	Finnish Meteorological Institute/WMO
<b>Stephanie Stevenson</b>	GOES Tropical Applications Developer, NOAA/NWS National Hurricane Center
<b>Kelly Turner</b>	NESDIS/NOAA Chief of Staff
<b>Louis Uccellini</b>	NWS Director
<b>Tim Walsh</b>	GOES-R Deputy Flight Project Manager



**Yunheng Xue**

Chinese Academy of Sciences

**Zhiyu Zhou**

North China Electric Power University





## **Appendix 6: List of Staff/Students hired by NOAA in the past years**

**None.**



## Appendix 7: CIMSS Board of Directors and Science Council

### CIMSS Board of Directors

The Board of Directors will consist of senior employees from NOAA and UW-Madison. The Board of Directors shall review the policies, research themes, and priorities of CIMSS, including budget and scientific activities and will also provide for the periodic external review of the scientific activities of CIMSS. The Director of CIMSS or his/her designee shall serve as a non-voting member of the Board of Directors. The NESDIS Cooperative Research Program Director will serve as a special advisor to the Council in an *ex officio* status. Current Board of Directors members include:

Marsha Mailick	Associate Vice Chancellor for Research and Graduate Education, UW–Madison
W. Paul Menzel	Interim Director, CIMSS, UW–Madison
Steve Ackerman	Interim Director, SSEC, UW–Madison
Greg Tripoli	Chair, Department of Atmospheric and Oceanic Sciences, UW-Madison
Steven Volz	Assistant Administrator for Satellite and Information Services, NOAA/NESDIS
Harry Cikanek	Director, Center for Satellite Applications and Research, NOAA/NESDIS
Jeff Key	Chief, Advanced Satellite Products Branch, NOAA/NESDIS
Jack A. Kaye	Associate Director for Research, NASA
Peter Hildebrand	Director, Earth-Sun Exploration Division of the Sciences and Exploration Directorate, NASA Goddard Space Flight Center
David F. Young	Director, Science Directorate, NASA Langley Research Center

### CIMSS Science Advisory Council

The Science Council will advise the CIMSS Director in establishing the broad scientific content of CIMSS programs, promoting cooperation among CIMSS, NOAA, NASA and other agencies, maintaining high scientific and professional standards, and preparing reports of CIMSS activities. All Science Advisory Council members shall be recommended and selected by the Director of CIMSS, in consultation with the Board of Directors. In addition the Executive Director of SSEC or designee shall be a Council member. Council members shall serve three-year terms. Reappointment is possible for additional three-year terms pending approval by the Board. The number of Council members shall be set by the Board, provided the number of University members equal the total number of agency members. The Director of CIMSS will serve as the Chairperson of the Council. The NESDIS Cooperative Research Program Director will serve as a special advisor to the Council in an *ex officio* status. Science Council members include:

Allen Huang	Distinguished Scientist, CIMSS, UW–Madison
Chris Velden	Senior Scientist, CIMSS, UW–Madison
Trina McMahan	Professor, College of Engineering, UW–Madison
Annemarie Schneider	Professor, SAGE, UW–Madison
Tristan L’Ecuyer	Professor, UW-Madison Atmospheric and Oceanic Sciences
Chris Kummerow	Professor, Department of Atmospheric Science, Colorado State University
Steve Goodman	GOES-R Program Scientist, NOAA/NESDIS/ORA
Satya Kalluri	Chief, Atmospheric Research and Applications Division, NOAA/NESDIS/ORA



Steve Platnick

Aqua Deputy Project Scientist, EOS Senior Project Scientist  
(acting), NASA Goddard Space Flight Center

Pat Minnis

Senior Research Scientist, NASA Langley Research Center



## Appendix 8: CIMSS Publications, 2015-2018

### CIMSS Peer-Reviewed Publications, 2015-2018

#### 2018

##### In Press, Accepted, or In Review

Kossin, J.P., 2018: A global slowdown of tropical cyclone translation speed. *Nature*, In Review.

Li, J., et al, 2018: Inter-comparison between VIIRS and CrIS by taking into account the CrIS sub-pixel cloudiness and viewing geometry. *Journal of Geophysical Research-Atmospheres*, Paper#2017JD027849R. Accepted.

Zhang, S., Pu, Z., and Velden, C., 2018: Impact of enhanced atmospheric motion vectors on HWRF hurricane analysis and forecasts with different data assimilation configurations. *Monthly Weather Review*, In Press, <https://doi.org/10.1175/MWR-D-17-0136.1>.

##### Peer-Reviewed Journal Articles

Blackwell, W.J., Braun, S., Bennartz, R., and Velden, C., 2018: An overview of the TROPICS NASA Earth Venture Mission. *Quarterly Journal of the Royal Meteorological Society*, DOI:10.1002/qu.3290.

Borbas, E.E., Hulley, G., Feltz, M., Knuteson, R., and Hook, S., 2018: The combined ASTER MODIS Emissivity over Land (CAMEL) Part 1: Methodology and high spectral resolution application. *Remote Sensing*, 10(4), 643, doi:10.3390/rs10040643.

Cintineo, J.L., Pavolonis, M.J., Sieglaff, J.M., Lindsey, D.T., Counce, L., Gerth, J., Rodenkirch, B., Brunner, J., and Gravelle, C., 2018: The NOAA/CIMSS ProbSevere Model: Incorporation of total lightning and validation. *Weather and Forecasting*, 33, 331-345, <https://doi.org/10.1175/WAF-D-17-0099.1>.

Costa, S.M.S., Negri, R.G., Ferreira, N.J., Schmit, T.J., Arai, N., Flauber, W., Ceballos, J., Vila, D., Rodrigues, J., Machado, L.A., Pereira, S., Bottino, M.J., Sismanoglu, R.A., and Langden, P., 2018. A successful practical experience with dedicated Geostationary Operational Environmental Satellites GOES-10 and -12 supporting Brazil. *Bulletin of the American Meteorological Society*, 99(1): 33-47.

Emanuel, K., Caroff, P., Delgado, S., Guard, C.C., Guishard, M., Hennon, C., Knaff, J., Knapp, K.R., Kossin, J., Schreck, C., Velden, C., and Vigh, J., 2018. On the desirability and feasibility of a global reanalysis of tropical cyclones. *Bulletin of the American Meteorological Society*, 99(2): 427-429.

Feltz, M., Borbas, E., Knuteson, R., Hulley, G., and Hook, S., 2018: The combined ASTER MODIS Emissivity over Land (CAMEL) Part 2: Uncertainty and validation. *Remote Sensing*, 10(5), 664, doi:10.3390/rs10050664.

Griffin, S.M., and Velden, C.S., 2018: Hazard avoidance products for convectively-induced turbulence in support of high-altitude Global Hawk aircraft missions. *Pure and Applied Geophysics*, 1420-9136, 1-11.

Herring, S.C., Christidis, N., Hoell, A., Kossin, J.P., Schreck, C.J.I., and Stott, P.A., 2018. Explaining extreme events of 2016 from a climate perspective: Introduction to Explaining extreme events of 2016 from a climate perspective. *Bulletin of the American Meteorological Society*, S1-S6.

Langford, A.O., Alvarez, R.J.I., Brioude, J., Evan, S., Iraci, L.T., Kirgis, G., Kuang, S., Leblanc, T.,



Newchurch, M. J., Pierce, R.B., Senff, C.J., and Yates, E.L., 2018. Coordinated profiling of stratospheric intrusions and transported pollution by the Tropospheric Ozone Lidar Network (TOLNet) and NASA Alpha Jet experiment (AJAX): Observations and comparison to FYSPLIT, RAQMS, and FLEXPART. *Atmospheric Environment*, 174: 1-14.

Li, S., Sun, D., Goldberg, M.D., Sjobrg, B., Santek, D., Hoffman, J.P., DeWeese, M., Restrepo, P., Lindsey, S., and Holloway, E., 2018. Automatic near real-time flood detection using Suomi-NPP/VIIRS data. *Remote Sensing of Environment*, 204: 672-689.

Mapes, B.E., Chung, E.S., Hannah, W.M., Masunaga, H., Wimmers, A.J., and Velden, C.S., 2018. The meandering margin of the meteorological moist tropics. *Geophysical Research Letters*, 45(2): 1177-1184.

Menzel, W.P., Schmit, T.J., Zhang, P., and Li, J., 2018. Satellite-based atmospheric infrared sounder development and applications. *Bulletin of the American Meteorological Society*, 99(3): 583-603.

Otkin, J.A., Potthast, R., and Lawless, A.S., 2018. Nonlinear bias correction for satellite data assimilation using Taylor series polynomials. *Monthly Weather Review*, 146(1): 263-285.

Schultz, J.M., Kossin, J.P., Shepherd, J.M., Ransdell, J.M., Walshe, R., Kelman, I., and Galea, S., 2018: Hurricane risks, health consequences, and response challenges for small island based populations: Observations from the 2017 Atlantic hurricane season. *Disaster Medicine and Public Health Preparedness*, doi:10.1017/dmp.2018.28.

Serio, C., Masiello, G., Camy-Peyret, C., Jacquette, E., Vandermarcq, O., Bermudo, F., Coppens, D., and Tobin, D., 2018: PCA determination of the radiometric noise of high spectral resolution infrared observations from spectral residuals: Application to IASI. *Journal of Quantitative Spectroscopy and Radiative Transfer*, 206, 8-21.

Stott, P.A., Christidis, N., Herring, S.C., Hoell, A., Kossin, J.P., and Schreck, C.J.I., 2018. Explaining extreme events of 2016 from a climate perspective: Future challenges in event attribution methodologies. *Bulletin of the American Meteorological Society*, S155-S157.

Zhao, X., Liu, Y., Yu, F., and Heidinger, A.K., 2018. Using long-term satellite observations to identify sensitive regimes and active regions of aerosol indirect effects for liquid clouds over global oceans. *Journal of Geophysical Research-Atmospheres*, 123(1): 457-472.

## 2017

### Books and Book Chapters

Knutson, T., J.P. Kossin, C. Mears, J. Perlwitz, and M.F. Wehner, 2017: Detection and attribution of climate change. In: *Climate Science Special Report: Fourth National Climate Assessment, Volume I*. U.S. Global Change Research Program, Washington, DC, 114-132, doi: 10.7930/J01834ND.

Kossin, J.P., T. Hall, T. Knutson, K.E. Kunkel, R.J. Trapp, D.E. Waliser, and M.F. Wehner, 2017: Extreme storms. In: *Climate Science Special Report: Fourth National Climate Assessment, Volume I*. U.S. Global Change Research Program, Washington, DC, 257-276, doi: 10.7930/J0S7KXX.

Lewis, John, with J.M. Phillips, W.P. Menzel, T.H. Vonder Haar, H. Moosmuller, F.B. House, and M.G. Fearon, 2018: *Verner Suomi: The Life and Work of the Founder of Satellite Meteorology*. Boston, MA, American Meteorological Society, xiii, 189p.

Perlwitz, J., T. Knutson, J.P. Kossin, and A.N. LeGrande, 2017: Large-scale circulation and climate



variability. In: *Climate Science Special Report: Fourth National Climate Assessment, Volume I*. U.S. Global Change Research Program, Washington, DC, 161-184, doi: 10.7930/J0RV0KVQ.

Wardlow, B.D., M.C. Anderson, C. Hain, W. Crow, J.A. Otkin, T. Tadesse, and A. Aghakouchak, 2017: *Advancements in Satellite Remote Sensing for Drought Monitoring*. In: *Drought and Water Crises: Integrating Science, Management, and Policy*. CRC Press, 542p.

Wuebbles, D.J., D.W. Fahey, K.A. Hibbard, B. DeAngelo, S. Doherty, K. Hayhoe, R. Horton, J.P. Kossin, P.C. Taylor, A.M. Waple, and C.P. Weaver, 2017: *Executive summary*. In: *Climate Science Special Report: Fourth National Climate Assessment, Volume I*. U.S. Global Change Research Program, Washington, DC, 12-34, doi: 10.7930/J0DJ5CTG.

Wuebbles, D.J., D.R. Easterlin, K. Hayhoe, T. Knutson, R.E. Kopp, J.P. Kossin, K.E. Kunkel, A.N. LeGrande, C. Mears, W.V. Sweet, P.C. Taylor, R.S. Vose, and M.F. Wehner, 2017: *Our globally changing climate*. In: *Climate Science Special Report: Fourth National Climate Assessment, Volume I*. U.S. Global Change Research Program, Washington, DC, 35-72, doi: 10.7930/J08S4N35.

### Peer-Reviewed Journal Articles

Ai, Y., Li, J., Shi, W., Schmit, T.J., Cao, C., and Li, W., 2017. Deep convective cloud characterizations from both broadband imager and hyperspectral infrared sounder measurements. *Journal of Geophysical Research-Atmospheres*, 122(3): 1700-1712.

Anderson, M.C., Hain, C.R., Jurecka, F., Trnka, M., Hlavinka, P., Dulaney, W., Otkin, J.A., Johnson, D., and Gao, F., 2017. Relationships between the evaporative stress index and winter wheat and spring barley yield anomalies in the Czech Republic. *Climate Research*, 70(2-3): 215-230.

Bennartz, R., Hoschen, H., Picard, B., Schroder, M., Stengel, M., Sus, O., Bojkov, B., Casadio, S., Diedrich, H., Eliasson, S., Fell, F., Fischer, J., Hollmann, R., Preusker, R., and Willen, U., 2017. An intercalibrated dataset of total column water vapour and wet tropospheric correction based on MWR on board ERS-1, ERS-2, and Envisat. *Atmospheric Measurement Techniques*, 10(4): 1387-1402.

Chai, T., Crawford, A., Stunder, B., Pavolonis, M.J., Draxler, R., and Stein, A., 2017. Improving volcanic ash predictions with the HYSPLIT dispersion model by assimilating MODIS satellite retrievals. *Atmospheric Chemistry and Physics*, 17(4): 2865-2879.

Cooper, S.J., Wood, N.B., and L'Ecuyer, T.S., 2017. A variational technique to estimate snowfall rate from coincident radar, snowflake, and fall-speed observations. *Atmospheric Measurement Techniques*, 10(7): 2571-2571.

Diak, G.R., 2017. Investigations of improvements to an operational GOES-satellite-data-based insolation system using pyranometer data from the US Climate Reference Network (USCRN). *Remote Sensing of Environment*, 195: 79-95.

Ding, J., Bi, L., Yang, P., Kattawar, G.W., Weng, F., Liu, Q., and Greenwald, T., 2017. Single-scattering properties of ice particles in the microwave regime: Temperature effect on the ice refractive index with implications in remote sensing. *Journal of Quantitative Spectroscopy and Radiative Transfer*, 190: 26-37.

Doyle, J.D., Moskaitis, J.R., Feldmeier, J.W., Ferek, R.J., Beaubien, M., Bell, M.M., Cecil, D.L., Creasey, R.L., Duran, P., Elsberry, R.L., Komaromi, W.A., Molinari, J., Ryglicki, D.R., Stern, D.P., Velden, C.S., Wang, X., Allen, T., Barrett, B.S., Black, P.G., Dunion, J.P., Emanuel, K.A., Harr, P.A., Harrison, L., Hendricks, E.A., Herndon, D., Jeffries, W.Q., Majumdar, S.J., Morre, J.A., Pu, Z., Rogers, R.F., Sanabia, E.R., Tripoli, G.J., and Zhang, D.-L., 2017. A view of tropical cyclones from above: The Tropical Cyclone



Intensity experiment. *Bulletin of the American Meteorological Society*, 98(10): 2113-2134.

Elsaesser, G.S., O'Dell, C.W., Lebock, M.D., Bennartz, R., Greenwald, T.J., and Wentz, F.J., 2017. The Multisensor Advanced Climatology of Liquid Water Path (MAC-LWP). *Journal of Climate*, 30(24): 10193-10210.

Feltz, M.L., Borg, L., Knuteson, R.O., Tobin, D., Revercomb, H., and Gambacorta, A., 2017. Assessment of NOAA NUCAPS upper air temperature profiles using COSMIC GPS radio occultation and ARM radiosondes. *Journal of Geophysical Research-Atmospheres*, 122(17): 9130-9153.

Feltz, M.L., Knuteson, R.O., and Revercomb, H.E., 2017. Assessment of COSMIC radio occultation and AIRS hyperspectral IR sounder temperature products in the stratosphere using observed radiances. *Journal of Geophysical Research-Atmospheres*, 122(16): 8593-8616.

Feng, L., Hu, C., Barnes, B.B., Mannino, A., Heidinger, A.K., Strabala, K., and Iraci, L.T., 2017. Cloud and sun-glint statistics derived from GOES and MODIS observations over the Intra-Americas Sea for GEO-CAPE mission planning. *Journal of Geophysical Research-Atmospheres*, 122(3): 1725-1745.

Foster, M.J., Ackerman, S.A., Bedka, K., Di Girolamo, L., Frey, R.A., Heidinger, A.K., Sun-Mack, S., Philips, C., Menzel, W.P., Minnis, P., and Zhao, G., 2017. State of the Climate in 2016: Cloudiness. *Bulletin of the American Meteorological Society*, 98(8): S27-S28.

Gartzke, J., Knuteson, R., Przybyl, G., Ackerman, S., and Revercomb, H., 2017. Comparison of satellite-, model-, and radiosonde-derived convective available potential energy in the Southern Great Plains region. *Journal of Applied Meteorology and Climatology*, 56(5): 1499-1513.

Griffin, S.M., 2017. Climatology of tropical overshooting tops in North Atlantic tropical cyclones. *Journal of Applied Meteorology and Climatology*, 56(6): 1783-1796.

Griffin, S.M., Otkin, J.A., Rozoff, C.M., Sieglaff, J.M., Crounce, L.M., and Alexander, C.R., 2017. Methods for comparing simulated and observed satellite infrared brightness temperatures and what do they tell us? *Weather and Forecasting*, 32(1): 5-25.

Griffin, S.M., Otkin, J.A., Rozoff, C.M., Sieglaff, J.M., Crounce, L.M., Alexander, C.R., Jensen, T.L., and Wolff, J.K., 2017. Seasonal analysis of cloud objects in the High-Resolution Rapid Refresh (HRRR) model using object-based verification. *Journal of Applied Meteorology and Climatology*, 56(8): 2317-2334.

Gumber, A. and Foster, M.J., 2017. A MODIS-derived value-added climatology of maritime cloud liquid water path that conserves solar reflectance. *Journal of Applied Meteorology and Climatology*, 56(6): 1767-1781.

Heymsfield, A., Kramer, M., Wood, N.B., Gettelman, A., Field, P.R., and Liu, G., 2017. Dependence of the ice water content and snowfall rate on temperature, globally: Comparison of in situ observations, satellite active remote sensing retrievals, and global climate model simulations. *Journal of Applied Meteorology and Climatology*, 56(1): 189-215.

Hoover, B.T., and R.H. Langland, 2017: NAVGEM forecast and observation impact experiments with assimilation of ECMWF analysis data in the global domain. *Journal of the Meteorological Society of Japan*, 95, 369-389.

Hoover, B.T., Santek, D.A., Daloz, A.-S., Zhong, Y., Dworak, R., Petersen, R.A., and Collard, A., 2017. Forecast impact of assimilating aircraft WVSS-II water vapor mixing ratio observations in the Global Data Assimilation System (GDAS). *Weather and Forecasting*, 32(4): 1603-1611.

Huang, M., Huang, B., and Huang, H.-L.A., 2017. Acceleration of the WRF Monin-Obukhov-Janjic



surface layer parameterization scheme on an MIC-based platform for weather forecast. *IEEE Journal of Selected Topics in Applied Earth Observations and Remote Sensing*, 10(10): 4399-4408.

Huang, M., Huang, B., and Huang, H.-L.A., 2017. Parallel construction of the WRF Pleim-Xiu land surface scheme with Intel Many Integrated Core (MIC) architecture. *IEEE Journal of Selected Topics in Applied Earth Observations and Remote Sensing*, 10(4): 1239-1246.

Huang, M., Carmichael, G.R., Pierce, R.B., Jo, D.S., Park, R.J., Flemming, J., Emmons, L.K., Bowman, K.W., Henze, D.K., Davila, Y., Sudo, K., Jonson, J.E., Lund, M.T., Janssens-Maenhut, G., Dentener, F.J., Keating, T.J., Oetjen, H., and Payne, V.H., 2017. Impact of intercontinental pollution transport on North American ozone air pollution: An HTAP phase 2 multi-model study. *Atmospheric Chemistry and Physics*, 17(9): 5721-5750.

Jang, H.-S., Sohn, B.-J., Chun, H.-W., Li, J., and Weisz, E., 2017. Improved AIRS temperature and moisture soundings with local a priori information for the 1DVAR method. *Journal of Atmospheric and Oceanic Technology*, 34(5): 1083-1095.

Jones, T.A., Koch, S., and Li, Z., 2017. Assimilating synthetic hyperspectral sounder temperature and humidity retrievals to improve severe weather forecasts. *Atmospheric Research*, 186(1): 9-25.

Kaldunski, B., Pierce, B., and Holloway, T., 2017. When stratospheric ozone hits ground-level regulation: Exceptional events in Wyoming. *Bulletin of the American Meteorological Society*, 98(5): 889-892.

Kim, M., Kim, H.M., Kim, J.W., Ki, S.-M., Velden, C., and Hoover, B., 2017. Effect of enhanced satellite-derived Atmospheric Motion Vectors on numerical weather prediction in East Asia using an adjoint-based observation impact method. *Weather and Forecasting*, 32(2): 579-594.

Kossin, J.P., 2017. Hurricane intensification along United States coast suppressed during active hurricane periods. *Nature*, 541(7637): 390-393.

Kuang, S., Newchurch, M.J., Johnson, M.S., Wang, L., Burris, J., Pierce, R.B., Eloranta, E.W., Pollack, I.B., Graus, M., de Gouw, J., Warneke, C., Ryerson, T.B., Markovic, M.Z., Holloway, J.S., Pour-Blazar, A., Huang, G., Liu, X., and Feng, N., 2017. Summertime tropospheric ozone enhancement associated with a cold front passage due to stratosphere-to-troposphere transport and biomass burning: Simultaneous ground-based lidar and airborne measurements. *Journal of Geophysical Research-Atmospheres*, 122(2): 1293-1311.

Lai, C., Yue, J., Xu, J., Straka, W.C.I., Miller, S.D., and Liu, X., 2017. Suomi NPP VIIRS/DNB imagery of nightglow gravity waves from various sources over China. *Advances in Space Research*, 59(8): 1951-1961.

Langford, A.O., Alvarex, R.J.I., Brioude, J., Fine, R., Gustin, M.S., Lin, M.Y., Marchbanks, R.D., Pierce, R.B., Sandberg, S.P., Senff, C.J., Weickmann, A.M., and Williams, E.J., 2017. Entrainment of stratospheric air and Asian pollution by the convective boundary layer in the southwestern US. *Journal of Geophysical Research-Atmospheres*, 122(2): 1312-1337.

Le Marshall, J., Howard, D., Xiao, Y., Daniels, J., Wanzong, S., Jung, J., Bresky, W., Bailey, A., Tingwell, C., Le, T., and Margetic, D., 2017. Himawari-8 Atmospheric Motion Vectors - Operational generation and assimilation. *Journal of Southern Hemisphere Earth Systems Science*, 67(1): 12-24.

Lee, Y.-K., Li, J., Li, Z., and Schmit, T., 2017. Atmospheric temporal variations in the pre-landfall environment of Typhoon Nangka (2015) observed by the Himawari-8 AHI. *Asia-Pacific Journal of Atmospheric Sciences*, 53(4): 431-443.

Li, J. and Han, W., 2017. A step forward toward effectively using hyperspectral IR sounding information in NWP. *Advances in Atmospheric Sciences*, 34: 1263-1264.





Li, J., Li, Z., Wang, P., Schmit, T.J., Bai, W., and Atlas, R., 2017. An efficient radiative transfer model for hyperspectral IR radiance simulation and applications under cloudy-sky conditions. *Journal of Geophysical Research-Atmospheres*, 122(14): 7600-7613.

Lin, H., Weygandt, S.S., Lim, A.H.N., Hu, M., Brown, J.M., and Benjamin, S.G., 2017. Radiance preprocessing for assimilation in the hourly updating rapid refresh mesoscale model: A study using AIRS data. *Weather and Forecasting*, 32(5): 1781–1800.

Lorenz, D.J., Otkin, J.A., Svoboda, M., Hain, C.R., Anderson, M.C., and Zhong, Y., 2017. Predicting US drought monitor states using precipitation, soil moisture, and evapotranspiration anomalies. Part I: Development of a nondiscrete USDM index. *Journal of Hydrometeorology*, 18(7): 1943–1962.

Lorenz, D.J., Otkin, J.A., Svoboda, M., Hain, C.R., Anderson, M.C., and Zhong, Y., 2017. Predicting US drought monitor states using precipitation, soil moisture, and evapotranspiration anomalies. Part II: Intraseasonal drought intensification forecasts. *Journal of Hydrometeorology*, 18(7): 1963-1982.

Meier, W.N., Stewart, J.S., Liu, Y., Key, J., and Miller, J.A., 2017. Operational implementation of sea ice concentration estimates from the AMSR2 sensor. *IEEE Journal of Selected Topics in Applied Earth Observations and Remote Sensing*, 10(9): 3904-3911.

Mueller, K.J., Wu, D.L., Lorvath, A., Jovanovic, V.M., Muller, J.-P., De Girolamo, L., Garay, M.J., Diner, D.J., Moroney, C.M., and Wanzong, S., 2017. Assessment of MISR Cloud Motion Vectors (CMVs) relative to GOES and MODIS Atmospheric Motion Vectors (AMVs). *Journal of Applied Meteorology and Climatology*, 56(3): 555-572.

Noh, Y.-J., Forsythe, J.M., Miller, S.D., Seaman, C.J., Li, Y., Heidinger, A.W., Lindsey, D.T., Rogers, M.A., and Partain, P.T., 2017. Cloud-base height estimation from VIIRS. Part I I: A statistical algorithm based on A-train satellite data. *Journal of Atmospheric and Oceanic Technology*, 34(3): 585-598.

Otkin, J.A., Lewis, W.E., Lenzen, A.J., McNoldy, B.D., and Majumdar, S.J., 2017. Assessing the accuracy of the cloud and water vapor fields in the hurricane WRF (HWRD) model using satellite infrared brightness temperatures. *Monthly Weather Review*, 145(5): 2027-2046.

Palermo, C., Claud, C., Dufour, A., Genthon, C., Wood, N.B., and L'Ecuyer, T., 2017. Evaluation of Antarctic snowfall in global meteorological reanalyses. *Atmospheric Research*, 190: 104-112.

Palermo, C., Genthon, C., Claud, C., Kay, J.E., Wood, N.B., and L'Ecuyer, T., 2017. Evaluation of current and projected Antarctic precipitation in CMIP5 models. *Climate Dynamics*, 48(1): 225-239.

Pan, L.L., Atlas, E.L., Salawitch, R.J., Honomichl, S.B., Bresch, J.F., Randel, W.J., Apel, E.C., Hornbrook, R.S., Weinheimer, A.J., Anderson, C.D., Andrews, S.J., Baidar, S., Beaton, S.P., Campos, T.L., Carpenter, L.J., Chen, D., Dix, B., Donets, V., Hall, S.R., Hanisco, T.F., Homeyer, C.R., Huey, L.G., Jensen, J.B., Kaser, L., Kinnison, D.E., Koenig, T.K., Lamarque, J.-F., Liu, C., Luo, J., Luo, Z.J., Montzka, D.D., Nicely, J.M., Pierce, R.B., Riemer, D.D., Robinson, T., Romashkin, P., Saiz-Lopez, A., Schauffler, S., Shieh, O., Stell, M.H., Ullmann, K., Vaughan, G., Volkamer, R., and Wolfe, G., 2017. The Convective Transport of Active Species in the Tropics (CONTRAST) experiment. *Bulletin of the American Meteorological Society*, 90(1): 106–128.

Platnick, S., Meyer, K.G., King, M.D., Wind, G., Amarasinghe, Marchant, B., Arnold, G.T., Zhang, Z., Hubanks, P.A., Holz, R.E., Yang, P., Ridgway, W.L., and Riedi, J., 2017. The MODIS cloud optical and microphysical products: Collection 6 updates and examples from Terra and Aqua. *IEEE Transactions on Geoscience and Remote Sensing*, 55(1): 502-525.

Plokhenko, Y., Menzel, W.P., Knuteson, R., and Revercomb, H.E., 2017. Mathematical aspects in the meteorological interpretation of satellite hyperspectral infrared measurements part II: Estimates of the



cloud absorption vertical profile of Hurricane Ioke on 28 August 2006. *International Journal of Remote Sensing*, 38(51): 57-79.

Poli, P., Dee, D.P., Saunders, R., John, V.O., Rayer, P., Schulz, J., Holmlund, K., Coppens, D., Klaes, D., Johnson, J.E., Esfandiari, A.E., Gerasimov, I.V., Zamkoff, E.B., Al-Jazrawi, A.F., Santek, D., Albani, M., Brunel, P., Fennig, K., Schroder, M., Kobayashi, S., Oertel, D., Dohler, W., Spankuch, D., and Bojinski, S., 2017. Recent advances in satellite data rescue. *Bulletin of the American Meteorological Society*, 98(7): 1471-1484.

Rausch, J., Meyer, K., Bennartz, R., and Platnick, S., 2017. Differences in liquid cloud droplet effective radius and number concentration estimates between MODIS collections 5.1 and 6 over global oceans. *Atmospheric Measurement Techniques*, 10(6): 2105-2116.

Reid, J.S., Kuehn, R., Holz, R.E., Eloranta, E.W., Kaku, K.C., Kuang, S., Newchurch, M.J., Thompson, A.M., Trepte, C.R., Zhang, J., Atwood, S.A., Hand, J.L., Holben, B.N., Minnis, P., and Posselt, D.J., 2017. Ground-based high spectral resolution lidar observation of aerosol vertical distribution in the summertime Southeast United States. *Journal of Geophysical Research-Atmospheres*, 122(5): 2970-3004.

Riihela, A., Key, J.R., Meirink, J.F., Munneke, P.K., Palo, T., and Karisson, K.-G., 2017. An intercomparison and validation of satellite-based surface radiative energy flux estimates over the Arctic. *Journal of Geophysical Research-Atmospheres*, 122(9): 4829-4848.

Rogers, R.F., Aberson, S., Bell, M.M., Cecil, D.J., Doyle, J.D., Kimerlain, T.B., Morgerman, J., Shay, L.K., and Velden, C., 2017. Rewriting the tropical record books: The extraordinary intensification of Hurricane Patricia (2015). *Bulletin of the American Meteorological Society*, 98(10): 2091-2112.

Ross, A., Holz, R.E., and Ackerman, S.A., 2017. Correlations of oriented ice and precipitation in marine midlatitude low clouds using collocated CloudSat, CALIOP, and MODIS observations. *Journal of Geophysical Research-Atmospheres*, 122(18): 8056-8070.

Schmit, T.J., Griffith, P., Gunshor, M.M., Daniels, J.M., Goodman, S.J., and Lebair, W.J., 2017. A closer look at the ABI on the GOES-R series: Supplement. *Bulletin of the American Meteorological Society*, 98(4).

Schmit, T.J., Griffith, P., Gunshor, M.M., Daniels, J.M., Goodman, S.J., and Lebair, W.J., 2017. A closer look at the ABI on the GOES-R series. *Bulletin of the American Meteorological Society*, 98(4): 681-698.

Seaman, C.J., Noh, Y.-J., Miller, S.D., Heidinger, A.K., and Lindsey, D.T., 2017. Cloud-base height estimation from VIIRS. Part I: Operational algorithm validation against CloudSat. *Journal of Atmospheric and Oceanic Technology*, 34(3): 567-583.

Sieron, S.B., Clothiaux, E.E., Zhang, F., Lu, Y., and Otkin, J.A., 2017. Comparison of using distribution-specific versus effective radius methods for hydrometeor single-scattering properties for all-sky microwave satellite radiance simulations with different microphysics parameterization schemes. *Journal of Geophysical Research-Atmospheres*, 122(13): 7027-7046.

Taghavi, F., Ovlad, E., and Ackerman, S.A., 2017. Enhancement and identification of dust events in the south-west region of Iran using satellite observations. *Journal of Earth System Science*, 126(2): doi:10.1007/s12040-017-0808-0.

Velden, C., Lewis, W.E., Bresky, W., Stettner, D., Daniels, J., and Wanzong, S., 2017. Assimilation of high-resolution satellite-derived Atmospheric Motion Vectors: Impact on HWRP forecasts of tropical cyclone track and intensity. *Monthly Weather Review*, 145(3): 1107-1125.

Velden, C., Olander, T., Herndon, D., and Kossin, J.P., 2017. Reprocessing the most intense historical



tropical cyclones in the satellite era using the Advanced Dvorak Technique. *Monthly Weather Review*, 145(3): 971-983.

Wang, P., Li, J., Li, Z., Lim, A.H.N., Li, J., Schmit, T.J., and Goldberg, M.D., 2017. The impact of Cross-track Infrared Sounder (CrIS) cloud-cleared radiances on Hurricane Joaquin (2015) and Matthew (2016) forecasts. *Journal of Geophysical Research-Atmospheres*, 122(24): 13201-13218.

Weisz, E., Baum, B.A., and Menzel, W.P., 2017. Fusion of satellite-based imager and sounder data to construct supplementary high spatial resolution narrowband IR radiances. *Journal of Applied Remote Sensing*, 11(3): doi:10.1117/1.JRS.11.036022.

Wu, D.L., Baum, B.A., Choi, Y.-S., Foster, M.J.K.K.-G., Heidinger, A., Poulsen, C., Pavolonis, M., Riedi, J., Roebeling, R., Sherwood, S., Thoss, A., and Watts, P., 2017. Toward global harmonization of derived cloud products. *Bulletin of the American Meteorological Society*, 98(2): ES49-ES52.

Yang, Y., Anderson, M., Gao, F., Hain, C., Kustas, W., Meyers, T., Crow, W., Finocchiaro, R., Otkin, J., Sun, L., and Yang, Y., 2017. Impact of tile drainage on evapotranspiration in South Dakota, USA, based on high spatiotemporal resolution evapotranspiration time series from a multisatellite data fusion system. *IEEE Journal of Selected Topics in Applied Earth Observations and Remote Sensing*, 10(6): 2550-2564.

Yates, E.L., Johnson, M.S., Iraci, L.T., Ryoo, J.-M., Pierce, R.B., Cullis, P.D., Gore, W., Ives, M.A., Johnson, B.J., Leblanc, T., Marreo, J.E., Sterling, C.W., and Tanaka, T., 2017. An assessment of ground level and free tropospheric ozone over California and Nevada. *Journal of Geophysical Research-Atmospheres*, 122(8): 10,089-10,102.

Yue, Q., Kahn, B.H., Fetzer, E.J., Wong, S., Frey, R., and Meyer, K.G., 2017. On the response of MODIS cloud coverage to global mean surface air temperature. *Journal of Geophysical Research-Atmospheres*, 122(2): 966-979.

Zhang, L., Rechtman, T., Karnauskas, K.B., Li, L., Donnelly, J.P., and Kossin, J.P., 2017. Longwave emission trends over Africa and implications for Atlantic hurricanes. *Geophysical Research Letters*, 44(17): 9075-9083.

Zhou, Y., Xiao, X., Zhang, G., Wangle, P., Bajgain, R., Dong, J., Jin, C., Basara, J.B., Anderson, M.C., Hain, C., and Otkin, J.A., 2017. Quantifying agricultural drought in tallgrass prairie region in the US Southern Great Plains through analysis of a water-related vegetation index from MODIS images. *Agricultural and Forest Meteorology*, 246: 111-112.

Zhu, L., Li, J., Zhao, Y., Gong, H., and Li, W., 2017. Retrieval of volcanic ash height from satellite-based infrared measurements. *Journal of Geophysical Research-Atmospheres*, 122(10): 5384-5379.

Zoogman, P., Liu, X., Suleiman, R.M., Pennington, W.F., Flittner, D.E., Al-Saadi, J.A., Hilton, B.B., Nicks, D.K., Newchurch, M.J., Carr, J.L., Janz, S.J., Andraschko, M.R., Arola, A., Baker, B.D., Canova, B.P., Chan Miller, C., Cohen, R.C., Davis, J.E., Dussault, M.E., Edwards, D.P., Fishman, J., Ghulam, A., Gonzalez Abad, G., Grutter, M., Herman, J.R., Houck, J., Jacob, D.J., Joiner, J., Kerridge, B.J., Kim, J., Krotkov, N.A., Lamsal, L., Li, C., Lindfors, A., Martin, R.V., McElroy, C.T., McLinden, C., Nattaj, V., Neil, D.O., Nowlan, C.R., O'Sullivan, E.J., Palmer, P.I., Pierce, R.B., Pippin, M.R., Saiz-Lopez, A.S.R.J.D., Szykman, J.J., Torres, O., Veeffkind, J.P., Veihelmann, B., Wang, H., Wang, J., and Chance, K., 2017. Tropospheric emissions: Monitoring of pollution (TEMPO). *Journal of Quantitative Spectroscopy and Radiative Transfer*, 186: 17-39.

Wilson, T., Wu, A., Shrestha, A., Geng, X., Wang, Z., Moeller, C., Frey, R., and Xiong, X., 2017: Development and implementation of an electronic crosstalk correction for bands 27-30 in Terra MODIS collection 6. *Remote Sensing*, 9(6), article 569.



## 2016

### Peer-Reviewed Journal Articles

Anderson, D.C., Nicely, J.M., Salawitch, R.J., Canty, T.P., Dickerson, R.R., Hanisco, T.F., Wolfe, G.M., Apel, E.C., Atlas, E., Bannan, T., Bauguitte, S., Blake, N.J., Bresch, J.F., Campos, T.L., Carpenter, L.J., Cohen, M.D., Evans, M., Fernandex, R.P., Kahn, B.H., Kinnison, D.E., Hall, S.R., Harris, N.R.P., Hornbrook, R.S., Lamarque, J.-F., Le Breton, M., Lee, J.D., Percival, C., Pfister, L., Pierce, R.B., Piemer, D.D., Saiz-Lopez, A., Stunder, B.J.B., Thompson, A.M., Ullmann, K., Vaughan, A., and Weinheimer, A.J., 2016. A pervasive role for biomass burning in tropical high ozone/low water structures. *Nature Communications*, doi:10.1038/ncomms10267.

Anderson, M.C., Hain, C.R., Jurecka, F., Trnka, M., Hlavinka, P., Dulaney, W., Otkin, J.A., Johnson, D., and Gao, F., 2016. An energy balance approach for mapping crop water stress and yield impacts over the Czech Republic. *Climate Research*, 70, 215-230.

Anderson, M.C., Zolin, C.A., Sentelhas, P.C., Hain, C.R., Semmens, K., Yilmaz, M.T., Gao, F., Otkin, J.A., and Tetrault, R., 2016. The Evaporative Stress Index as an indicator of agricultural drought in Brazil: An assessment based on crop yield impacts. *Remote Sensing of Environment*, 174(1): 82-99.

Arvani, B., Pierce, R.B., Lyapustin, A.I., Wang, Y., Ghermandi, G., and Teggi, S., 2016. Seasonal monitoring and estimation of regional aerosol distribution over Po valley, northern Italy, using a high-resolution MAIAC product. *Atmospheric Environment*, 141: 106-121.

Baukabara, S.A., Zhu, T., Tolman, H.L., Lord, S., Goodman, S., Atlas, R., Goldberg, M., Auligne, T., Pierce, B., Cucurull, L., Zupanski, M., Zhang, M., Moradi, I., Otkin, J., Santek, D., Hoover, B., Pu, Z., Zhan, X., Hain, C., Kalnay, E., Hotta, D., Nolin, S., Bayler, E., Mehra, A., Casey, S.P.F., Lindsey, D., Grasso, L., Kumar, V.K., Powell, A., Xu, J., Greenwald, T., Zajic, J., Li, J., Li, J., Li, B., Liu, H., Fang, L., Wang, P., and Chen, T.-C., 2016. S4: An O2R/R2O infrastructure for optimizing satellite data utilization in NOAA numerical modeling systems. A step toward bridging the gap between research and operations. *Bulletin of the American Meteorological Society*, 97(12): 2359–2378.

Baylon, P.M., Jeffe, D.A., Pierce, R.B., and Gustin, M.S., 2016. Interannual variability in baseline ozone and its relationship to surface ozone in the western US. *Environmental Science and Technology*, 50(6): 2994-3001.

Boukabara, S.-A., Moradi, I., Atlas, R., Casey, S.P.F., Cucurull, L., Hoffman, R.N., Ide, K., Kumar, V.K., Li, R., Li, Z., Masutani, M., Shahroudi, N., Woollen, J., and Zhou, Y., 2016. Community Global Observing System Simulation Experiment (OSSE) Package (CGOP): Description and usage. *Journal of Atmospheric and Oceanic Technology*, 33(8): 1759–1777.

Brunner, J., Pierce, R.B., and Lenzen, A., 2016. Development and validation of satellite-based estimates of surface visibility. *Atmospheric Measurement Techniques*, 9(2): 409-422.

Cassano, J.J., Nigro, M.A., and Lazzara, M.A., 2016. Characteristics of the near-surface atmosphere over the Ross Ice Shelf, Antarctica. *Journal of Geophysical Research-Atmospheres*, 121(7): 3339-3362.

Christensen, M.W., Behrangi, A., L'Ecuyer, T.S., Wood, N.B., Lebsock, M.D., and Stephens, G.L., 2016. Arctic observation and reanalysis integrated system: A new data product for validation and climate study. *Bulletin of the American Meteorological Society*, 97(6): 907-915.

Cintineo, R.M., Otkin, J.A., Jones, T.A., Koch, S., and Stensrud, D.J., 2016. Assimilation of synthetic GOES-R ABI infrared brightness temperatures and WSR-88D radar observations in a high-resolution



OSSE. Monthly Weather Review, 144(9): 3159-3180.

Crawford, A.M., Stunder, B.J.B., Ngan, F., and Pavlonis, M.J., 2016. Initializing HYSPLIT with satellite observations of volcanic ash: A case study of the 2008 Kasatochi eruption. *Journal of Geophysical Research-Atmospheres*, 121(18): 10786-10803.

Di, D., Ai, Y., Li, J., Shi, W., and Lu, N., 2016. Geostationary satellite-based 6.7 micron band best water vapor information layer analysis over the Tibetan Plateau. *Journal of Geophysical Research-Atmospheres*, 121(9): 4600–4613.

Ding, J., Yang, P., Holz, R.E., Platnick, S., Meyer, K.G., Vaughan, M.A., Hu, Y., and King, M.D., 2016. Ice cloud backscatter study and comparison with CALIPSO and MODIS satellite data. *Optics Express*, 24(1): 620-636.

Foster, M.H., Ackerman, S.A., Bedka, K., Frey, R.A., Di Girolamo, L., Heidinger, A.K., Sun-Mack, S., Maddux, B.C., Menzel, W.P., Minnis, P., Stegel, M., and Zhao, G., 2016. State of the climate in 2015: Cloudiness. *Bulletin of the American Meteorological Society*, 97(8, supplement): S28-S29.

Foster, M.J., Heidinger, A., Hiley, M., Wanzong, S., Walther, A., and Botambekov, D., 2016. PATMOS-x cloud climate record trend sensitivity to reanalysis products. *Remote Sensing*, 8(5): doi:10.3390/rs8050424.

Gao, L., Li, J., Chen, L., Zhang, L., and Heidinger, A.K., 2016. Retrieval and validation of atmospheric aerosol optical depth from AVHRR over China. *IEEE Transactions on Geoscience and Remote Sensing*, 54(11): 6280-6291.

Grasso, L., Lindsey, D.T., Seaman, C.J., Stocks, B., and Rabin, R.M., 2016. Satellite observations of plume-like streaks in a cloud field in Canada. *Pure and Applied Geophysics*, 173(9): 3103-3110.

Gravelle, C.M., Mecikalski, J.R., Line, W.E., Bedka, K.M., Petersen, R.A., Sieglaff, J.M., Stano, G.T., and Goodman, S.J., 2016. Demonstration of a GOES-R satellite convective toolkit to "bridge the gap" between severe weather watches and warnings: An example from the 20 May 2013 Moore, Oklahoma, tornado outbreak. *Bulletin of the American Meteorological Society*, 97(1): 69-84.

Greenwald, T.J., Pierce, R.B., Schaack, T., Otkin, J., Rogal, M., Bah, K., Lenzen, A., Nelson, J., Li, J., and Huang, H.-L., 2016. Real-time simulation of the GOES-R ABI for user readiness and product evaluation. *Bulletin of the American Meteorological Society*, 97(2): 245-261.

Griffin, S.M., Bedka, K.M., and Velden, C.S., 2016. A method for calculating the height of overshooting convective cloud tops using satellite-based IR imager and CloudSat cloud profiling radar observations. *Journal of Applied Meteorology and Climatology*, 55(2): 479-491.

Gultepe, I., Rabin, R., Ware, R., and Pavlonis, M., 2016. Chapter Three: Light snow precipitation and effects on weather and climate. *Advances in Geophysics*, 57: 147-210.

Han, H., Li, J., Goldberg, M., Wang, P., Li, J., Li, Z., Sohn, B.-J., and Li, J., 2016. Microwave sounder cloud detection using a collocated high-resolution imager and its impact on radiance assimilation in tropical cyclone forecasts. *Monthly Weather Review*, 144(10): 3937-3959.

Heidinger, A., Foster, M., Botambekov, D., Hiley, M., Walther, A., and Li, Y., 2016. Using the NASA EOS A-train to probe the performance of the NOAA PATMOS-x cloud fraction CDR. *Remote Sensing*, 8(6): doi:10.3390/rs8060511.

Herring, S.C., Hoell, A., Hoerling, M.P., Kossin, J.P., Schreck, C.J.I., and Stott, P.A., 2016. Explaining extreme events of 2015 from a climate perspective: Introduction to explaining extreme events of 2015 from a climate perspective. *Bulletin of the American Meteorological Society*, 97(12): S1-S3.



- Herring, S.C., Hoell, A., Hoerling, M.P., Kossin, J.P., Schreck, C.J.I., and Stott, P.A., 2016. Explaining extreme events of 2015 from a climate perspective: Summary and broader context. *Bulletin of the American Meteorological Society*, 97(12): S141-S145.
- Heymsfield, A.J., Matrosov, S.Y., and Wood, N.B., 2016. Toward improving ice water content and snow-rate retrievals from radars, part I: X and W bands, emphasizing CloudSat. *Journal of Applied Meteorology and Climatology*, 55(9): 2063–2090.
- Hillger, D., Kopp, T., Seaman, C., Miller, S., Lindsey, D., Stevens, E., Solbrig, J., Straka, W.I., Kreller, M., Kuciauskas, A., and Terborg, A., 2016. User validation of VIIRS satellite imagery. *Remote Sensing*, 8(1): doi:10.3390/rs8010011.
- Hioki, S., Yang, P., Baum, B.A., Platnick, S., Meyer, K.G., King, M.D., and Riedi, J., 2016. Degree of ice particle surface roughness inferred from polarimetric observations. *Atmospheric Chemistry and Physics*, 16(12): 7545-7558.
- Holz, R.E., Platnick, S., Meyer, K., Vaughan, M., Heidinger, A., Yang, P., Wing, G., Dutcher, S., Ackerman, S., Amarasinghe, N., Nagle, F., and Wang, C., 2016. Resolving ice cloud optical thickness biases between CALIOP and MODIS using infrared retrievals. *Atmospheric Chemistry and Physics*, 16(8): 5075-5090.
- Key, J., Wang, X., Liu, Y., Dworak, R., and Letterly, A., 2016. The AVHRR Polar Pathfinder climate data records. *Remote Sensing*, 8(3): doi:10.3390/rs8030167 .
- Knapp, K.R., Matthews, J.L., Kossin, J.P., and Hennon, C.C., 2016. Identification of tropical cyclone storm types using crowdsourcing. *Monthly Weather Review*, 144(10): 3783-3798.
- Kossin, J.P. and DeMaria, M., 2016. Reducing operational hurricane intensity forecast errors during eyewall replacement cycles. *Weather and Forecasting*, 31(2): 601-608.
- Kossin, J.P., Emanuel, K.A., and Camargo, S.J., 2016. Past and projected changes in Western North Pacific tropical cyclone exposure. *Journal of Climate*, 29(16): 5725–5739.
- Kossin, J.P., Emanuel, K.A., and Vecchi, G.A., 2016. Comment on 'Roles of interbasin frequency changes in the poleward shifts of the maximum intensity location of tropical cyclones'. *Environmental Research Letters*, 11: doi:10.1088/1748-9326/6/068001.
- Kulie, M.S., Milani, L., Wood, N.B., Tushaus, S.A., Bennartz, R., and L'Ecuyer, T., 2016. A shallow cumuliform snowfall census using spaceborne radar. *Journal of Hydrometeorology*, 17(4): 1261-1279.
- Le Marshall, J., Xiao, Y., Howard, D., Tingwell, C., Freeman, J., Gregory, P., Le, T., Margetic, D., Morrow, T., Daniels, J., Jung, J., Bresky, W., Bailey, A., and Wanzong, S., 2016. First results from the generation and assimilation of 10-minute atmospheric motion vectors in the Australian region. *Journal of Southern Hemisphere Earth System Science*, 66(1): 12-18.
- Letterly, A., Key, J., and Liu, Y., 2016. The influence of winter cloud on summer sea ice in the Arctic, 1983-2013. *Journal of Geophysical Research-Atmospheres*, 121(5): 2178-2187.
- Li, J., Li, X., Huang, B., and Zhao, L., 2016. Hopfield neural network approach for supervised nonlinear spectral unmixing. *IEEE Geoscience and Remote Sensing Letters*, 13(7): 1002-1006.
- Li, J., Wang, P., Han, H., Li, K., and Zheng, J., 2016. On the assimilation of satellite sounder data in cloudy skies in numerical weather prediction models. *Journal of Meteorological Research*, 30(2): 169-182.



- Line, W.E., Schmit, T.J., Lindsey, D.T., and Goodman, S.J., 2016. Use of geostationary super rapid scan satellite imagery by the Storm Prediction Center. *Weather and Forecasting*, 31(4): 483–494.
- Liu, C.-Y., Li, J., Ho, S.-P., Liu, G.-R., Lin, T.-H., and Young, C.-C., 2016. Retrieval of atmospheric thermodynamic state from synergistic use of radio occultation and hyperspectral infrared radiances. *IEEE Journal of Selected Topics in Applied Earth Observations and Remote Sensing*, 9(2): 744-756.
- Liu, Y., Key, J., and Mahoney, R., 2016. Sea and freshwater ice concentration from VIIRS on Suomi NPP and the future JPSS satellites. *Remote Sensing*, 8(6): doi:3390/rs8060523.
- Liu, Y. and Key, J.R., 2016. Assessment of Arctic cloud cover anomalies in atmospheric reanalysis products using satellite data. *Journal of Climate*, 29(17): 6065–6083.
- Marais, W.J., Holz, R.E., Hu, Y.H., Kuehn, R.E., Eloranta, E.E., and Willett, R.M., 2016. Approach to simultaneously denoise and invert backscatter and extinction from photon-limited atmospheric lidar observations. *Applied Optics*, 55(29): 8314-8334.
- Menzel, W.P., Tobin, D.C., and Revercomb, H.E., 2016. Infrared remote sensing with meteorological satellites. *Advances in Atomic, Molecular and Optical Physics*, 65: 193-264.
- Menzel, W.P., Frey, R.A., Borbas, E.E., Baum, B.A., Cureton, G., and Bearson, N., 2016. Reprocessing of HIRS satellite measurements from 1980 to 2015: Development toward a consistent decadal cloud record. *Journal of Applied Meteorology and Climatology*, 55(11): 2397-2410.
- Meyer, K., Platnick, S., Arnold, G.T., Holz, R.E., Veglio, P., Yorks, J., and Wang, C., 2016. Cirrus cloud optical and microphysical property retrievals from eMAS during SEAC4RS using bi-spectral reflectance measurements within the 1.88 micron water vapor absorption band. *Atmospheric Measurement Techniques*, 9: 1743-1753.
- Mielikainen, J., Huang, B., and Huang, H.-L.A., 2016. Optimizing Purdue-Lin microphysics scheme for Intel Xeon Phi coprocessor. *IEEE Journal of Selected Topics in Applied Earth Observations and Remote Sensing*, 9(1): 425-438.
- Mielikainen, J., Price, E., Huang, B., Huang, H.-L.A., and Lee, T., 2016. GPU Compute Unified Device Architecture (CUDA)-based parallelization of the RRTMG shortwave rapid radiative transfer model. *IEEE Journal of Selected Topics in Applied Earth Observations and Remote Sensing*, 9(2): 921-931.
- Miller, D.J., Zhang, Z., Ackerman, A.S., Platnick, S., and Baum, B.A., 2016. The impact of cloud vertical profile on liquid water path retrieval based on the bispectral method: A theoretical study based on large-eddy simulations of shallow marine boundary layer clouds. *Journal of Geophysical Research-Atmospheres*, 121(8): 4122-4141.
- Miller, S.D., Schmit, T., Seaman, C.J., Lindsey, D.T., Gunshor, M.M., Kohrs, R.A., Sumida, Y., and Hillger, D., 2016. A sight for sore eyes: The return of true color to geostationary satellites. *Bulletin of the American Meteorological Society*, 97(10): 1803-1816.
- Miyazaki, Y., Coburn, S., Oho, K., Ho, D.T., Pierce, R.B., Kawamura, K., and Volkamer, R., 2016. Contribution of dissolved organic matter to submicron water-soluble organic aerosols in the marine boundary layer over the eastern equatorial Pacific. *Atmospheric Chemistry and Physics*, 16(12): 7695-7707.
- Nalli, N.R., Smith, W.L., and Liu, Q., 2016. Angular effect of undetected clouds in infrared window radiance observations: Aircraft experimental analyses. *Journal of the Atmospheric Sciences*, 73(5): 1987-2010.



Neely, H.L., Morgan, C.L.S., Hallmark, C.T., McInnes, K.J., and Molling, C.C., 2016. Apparent electrical conductivity response to spatially variable vertisol properties. *Geoderma*, 263: 168-175.

Otkin, J.A., Anderson, M.C., Hain, C., Svoboda, M., Johnson, D., Mueller, R., Tadesse, T., Wardlow, B., and Brown, J., 2016. Assessing the evolution of soil moisture and vegetation conditions during the 2012 United States flash drought. *Agricultural and Forest Meteorology*, 218-219: 230-242.

Painemal, D., Greenwald, T., Cadeddu, M., and Minnis, P., 2016. First extended validation of satellite microwave liquid water path with ship-based observations of marine low clouds. *Geophysical Research Letters*, 43(12): 6563–6570.

Petersen, R.A., 2016. On the impact and benefits of AMDAR observations in operational forecasting, part 1: A review of the impact of automated aircraft wind and temperature reports. *Bulletin of the American Meteorological Society*, 97(4): 585–602.

Petersen, R.A., Crouce, L., Mamrosh, R., Baker, R., and Pauley, P., 2016. On the impact and future benefits of AMDAR observations in operational forecasting, part II: Water vapor observations. *Bulletin of the American Meteorological Society*, 97(11): 2117–2133.

Pettersen, C., Bennartz, R., Kulie, M.S., Merrelli, A.J., Shupe, M.D., and Turner, D.D., 2016. Microwave signatures of ice hydrometeors from ground-based observations above Summit, Greenland. *Atmospheric Chemistry and Physics*, 16(7): 4743-4756.

Plokhenko, Y., Menzel, W.P., Knuteson, R., and Revercomb, H.E., 2016. Mathematical aspects of the meteorological interpretation of satellite hyperspectral infrared measurement part 1: Statement of the inverse problem for estimation of the cloud absorption vertical profile. *International Journal of Remote Sensing*, 37(7): 1601-1619.

Rabin, R.M., Gultepe, I., Kuligowski, R.J., and Heidinger, A.K., 2016. Monitoring snow using geostationary satellite retrievals during the SAAWSO Project. *Pure and Applied Geophysics*, 173(9): 3085-3102.

Reid, J.S., Lagrosas, N.D., Jonsson, H.H., Reid, E.A., Atwood, S.A., Boyd, T.J., Ghate, V.P., Xian, P., Posselt, D.J., Simpas, J.B., Uy, S.N., Zaiger, K., Blake, D.R., Bucholtz, A., Campbell, J.R., Chew, B.N., Cliff, S.S., Holben, B.N., Holz, R.E., Hyer, E.J., Kreidenweis, S.M., Kuciauskas, A.P., Lolli, S., Oo, M., Perry, K.D., Salinas, S.V., Sessions, W.R., Smirnov, A., Walker, A.L., Wang, Q., Yu, L., Zhang, J., and Zhao, Y., 2016. Aerosol meteorology of Maritime Continent for the 2012 7SEAS southwest monsoon intensive study - part 2: Philippine receptor observations of fine-scale aerosol behavior. *Atmospheric Chemistry and Physics*, 16(22): 14057-14078.

Reid, J.S., Xian, P., Holben, B.N., Hyer, E.J., Reid, E.A., Salinas, S.V., Zhang, J., Campbell, J.R., Chew, B.N., Holz, R.E., Kuciauskas, A.P., Lagrosas, N., Posselt, D.J., Sampson, C.R., Walker, A.L., Welton, E.J., and Zhang, C., 2016. Aerosol meteorology of the Maritime Continent for the 2012 7SEAS southwest monsoon intensive study - part 1: Regional-scale phenomena. *Atmospheric Chemistry and Physics*, 16(22): 1441-14056.

Rink, T., Menzel, W.P., Gumley, L., and Strabala, K., 2016. HYDRA2: A multispectral data analysis toolkit for sensors on Suomi-NPP and other current satellite platforms. *Bulletin of the American Meteorological Society*, 97(7): 1283–1294.

Roman, J., Knuteson, R., Ackerman, S., and Revercomb, H., 2016. Estimating minimum detection times for satellite remote sensing of trends in mean and extreme precipitable water vapor. *Journal of Climate*, 29(22): 8211-8230.





Roman, J., Knuteson, R., August, T., Hultberg, T., Ackerman, S., and Revercomb, H., 2016. A global assessment of NASA AIRS v6 and EUMETSAT IASI v6 precipitable water vapor using ground-based GPS SuomiNet stations. *Journal of Geophysical Research-Atmospheres*, 121(15): 8925–8948.

Saide, P.E., Thompson, G., Eidhammer, T., da Silva, A.M., Pierce, R.B., and Carmichael, G.R., 2016. Assessment of biomass burning smoke influence on environmental conditions for multiyear tornado outbreaks by combining aerosol-aware microphysics and fire emission constraints. *Journal of Geophysical Research-Atmospheres*, 121(17): 10294-10311.

Song, S., Schmidt, K.S., Pilewskie, P., King, M.D., Heidinger, A.K., Walther, A., Iwabuchi, H., Wind, G., and Coddington, O.M., 2016. The spectral signature of cloud spatial structure in shortwave irradiance. *Atmospheric Chemistry and Physics*, 16(21): 13791-13806.

Staten, P.W., Kahn, B.H., Schreier, M.M., and Heidinger, A.K., 2016. Subpixel characterization of HIRS spectral radiances using cloud properties from AVHRR. *Journal of Atmospheric and Oceanic Technology*, 33(7): 1519-1538.

Thompson, G., Tewari, M., Ikeda, K., Tessendorf, S., Weeks, C., Otkin, J., and Kong, F., 2016. Explicitly-coupled cloud physics and radiation parameterizations and subsequent evaluation in WFR high-resolution convective forecasts. *Atmospheric Research*, 168(1): 92-104.

Tobin, D., Holz, R., Nagle, F., and Revercomb, H., 2016. Characterization of the Climate Absolute Radiance and Refractivity Observatory (CLARREO) ability to serve as an infrared satellite intercalibration reference. *Journal of Geophysical Research-Atmospheres*, 121(8): 4258-4271.

Veglio, P., Tobin, D.C., Dutcher, S., Quinn, G., and Moeller, C.C., 2016. Long-term assessment of Aqua MODIS radiance observation using comparisons with AIRS and IASI. *Journal of Geophysical Research-Atmospheres*, 121(14): 8460–8471.

Wagner, T.J. and Kleiss, J.M., 2016. Error characteristics of ceilometer-based observations of cloud amount. *Journal of Atmospheric and Oceanic Technology*, 33(7): 1557-1567.

Walsh, K.J.E., McBride, J.L., Klotzbach, P.J., Balachandran, S., Camargo, S.J., Holland, G., Knutson, T.R., Kossin, J.P., Lee, T., Sobel, A., and Sugi, M., 2016. Tropical cyclones and climate change. *Wiley Interdisciplinary Reviews-Climate Change*, 7(1): 65-89.

Wang, X., Key, J., Kwok, R., and Zhang, J., 2016. Comparison of Arctic sea ice thickness from satellites, aircraft, and PIOMAS data. *Remote Sensing*, 8(9): doi:10.3390/rs8090713.

Wimmers, A.J. and Velden, C.S., 2016. Advancements in objective multisatellite tropical cyclone center fixing. *Journal of Applied Meteorology and Climatology*, 55(1): 197–212.

Wu, X., Huang, B., Wang, L., and Zhang, J., 2016. GPU-based parallel design of the hyperspectral signal subspace identification by minimum error (HySime). *IEEE Journal of Selected Topics in Applied Earth Observations and Remote Sensing*, 9(9): 4400-4406.

Yan, Q., Wei, T., Korty, R.L., Kossin, J.P., Zhang, Z., and Wang, H., 2016. Enhanced intensity of global tropical cyclones during the mid-Pliocene warm period. *Proceedings of the National Academy of Sciences of the United States of America (PNAS)*, 113(46): 12963-12967.

Zhang, K., Wu, C., and Li, J., 2016. Retrieval of atmospheric temperature and moisture vertical profiles from satellite advanced infrared sounder radiances with a new regularization parameter selecting method. *Journal of Meteorological Research*, 30(3): 356-370.

Zhao, X., Heidinger, A.K., and Walther, A., 2016. Climatology analysis of aerosol effect on marine water



cloud from long-term satellite climate data records. *Remote Sensing*, 8(4): doi:10.3390/rs8040300.

Zheng, X., Ackerman, S., Ferraro, R.D., Lee, T.J., Hurray, J.J., Pawson, S., Reynolds, C., and Teixeira, J., 2016. Challenges and opportunities in NASA weather research. *Bulletin of the American Meteorological Society*, 97(7): ES137-ES140.

Zhou, D.K., Liu, X., Larar, A.M., Tian, J., Smith, W.L., Kizer, S.H., Wu, W., Liu, Q., and Goldberg, M.D., 2016. First Suomi NPP Cal/Val campaign: Intercomparison of satellite and aircraft sounding retrievals. *IEEE Journal of Selected Topics in Applied Earth Observations and Remote Sensing*, 9(9): 4037-4046.

## 2015

### Peer-Reviewed Journal Articles

Azeem, I., Yue, J., Hoffmann, L., Miller, S.D., Straka, W.C.I., and Crowley, G., 2015. Multisensor profiling of a concentric gravity wave event propagating from the troposphere to the ionosphere. *Geophysical Research Letters*, 42(19): 7874-7880.

Baldassarre, G., Pozzoli, L., Schmidt, C.C., Unal, A., Kindap, T., Menzel, W.P., Whitburn, S., Coheur, P.-F., Kavgaci, A., and Kaiser, J.W., 2015. Using SEVIRI fire observations to drive smoke plumes in the CMAQ air quality model: a case study over Antalya in 2008. *Atmospheric Chemistry and Physics*, 15(14): 8539-8558.

Barnes, R.A., Brown, S.W., Lykke, K.R., Guenther, B., Butler, J.J., Schwarting, T., Turpie, K., Moyer, D., DeLuccia, F., and Moeller, C., 2015. Comparison of two methodologies for calibrating satellite instruments in the visible and near-infrared. *Applied Optics*, 54(35): 10376-10396.

Bedka, K.M., Wang, C., Rogers, R., Carey, L.D., Feltz, W., and Kanak, J., 2015. Examining deep convective cloud evolution using total lightning, WSR-88D, and GOES-14 super rapid scan datasets. *Weather and Forecasting*, 30(3): 571-590.

Campbell, J.R., Vaughan, M.A., Oo, M., Holz, R.E., Lewis, J.R., and Welton, E.J., 2015. Distinguishing cirrus cloud presence in autonomous lidar measurements. *Atmospheric Measurement Techniques*, 8(1): 435-449.

Chang, Y.-L., Wang, Y.C., Fu, Y.-S., Han, C.-C., Chansot Jocelyn, and Huang, B., 2015. Multisource data fusion and Fisher criterion-based nearest feature space approach to landslide classification. *IEEE Journal of Selected Topics in Applied Earth Observations and Remote Sensing*, 8(2): 576-588.

Cho, H.-M., Zhang, Z., Meyer, K., Lebsock, M., Platnick, S., Ackerman, A.S., Di Girolamo, L., C.-Labonnote, L., Cornet, C., Riedi, J., and Holz, R.E., 2015. Frequency and causes of failed MODIS cloud property retrievals for liquid phase clouds over global oceans. *Journal of Geophysical Research-Atmospheres*, 120(9): 4132-4154.

Cureton, G.P., 2015. Retrieval of higher order ocean spectral information from sunglint. *IEEE Transactions on Geoscience and Remote Sensing*, 53(1): 36-50.

Daloz, A.S., Camargo, S.J., Kossin, J.P., Emanuel, K., Horn, M., Jonas J. A., Kim, D., LaRow, T., Kim, Y.-K., Patricola, C.M., Roberts, M., Scoccimarro, E., Shaevitz, D., Vidale, P.L., Wang, H., Wehner, M., and Zhao, M., 2015. Cluster analysis of downscaled and explicitly simulated North Atlantic tropical cyclone tracks. *Journal of Climate*, 28(4): 1333-1361.



- Daniels, T., Smith, W.L.Sr., and Kireev, S., 2015. Simulation of airborne radiometric detection of wake vortices. *IEEE Transactions on Geoscience and Remote Sensing*, 53(12): 6336-6343.
- Fine, R., Miller, M.B., Burley, J., Jaffe, D.A., Pierce, R.B., Lin, M., and Gustin, M.S., 2015. Variability and sources of surface ozone at rural sites in Nevada, USA: Results from two years of the Nevada Rural Ozone Initiative. *Science of the Total Environment*, 530: 471-482.
- Folmer, M.J., DeMaria, M., Ferraro, R., Beven, J., Brennan, M., Daniels, J., Kuligowski, R., Meng, H., Rudlosky, S., Zhao, L., Knaff, J., Kusselson, S., Miller, S.D., Schmit, T.J., Velden, C., and Zavodsky, B., 2015. Satellite tools to monitor and predict Hurricane Sandy (2012): Current and emerging products. *Atmospheric Research*, 166: 165-181.
- Foster, M., Ackerman, S.A., Heidinger, A.K., and Maddux, B.C., 2015. State of the climate in 2014: Cloudiness. *Bulletin of the American Meteorological Society*, 96(7, supplement ): S24-S26.
- Gu, L., Zhao, K., and Huang, B., 2015. Microwave unmixing with video segmentation for inferring broadleaf and needleleaf brightness temperatures and abundances from mixed forest observations. *IEEE Transactions on Geoscience and Remote Sensing*, 54(1): 279-286.
- Gultepe, I., Zhou, B., Milbrandt, J., Bott, A., Li, Y., Heymsfield, A.J., Ferrier, B., Ware, R., Pavolonis, M., Kuhn, T., Gurka, J., Liu, P., and Cermak, J., 2015. A review on ice fog measurements and modeling. *Atmospheric Research*, 151: 2-19.
- He, J., Zhang, Y., Glotfelty, T., He, R., Bennartz, R., Rausch, J., and Sartelet, K., 2015. Decadal simulation and comprehensive evaluation of CESM/CAM5.1 with advanced chemistry, aerosol microphysics, and aerosol-cloud interactions. *Journal of Advances in Modeling Earth Systems*, 7(1): 110-141.
- Heidinger, A.K., Li, Y., Baum, B.A., Holz, R.E., Platnick, S., and Yang, P., 2015. Retrieval of cirrus cloud optical depth under day and night conditions from MODIS Collection 6 cloud property data. *Remote Sensing*, 7: 7257-7271.
- Hennon, C.C., Knapp, K.R., Schreck, C.J.I., Stevens, S.E., Kossin, J.P., Thorne, P.W., Hennon, P.A., Kruk, M.C., Rennie, J., Gadea, J.-M., Striagl, M., and Carley, I., 2015. Cyclone center: Can citizen scientists improve tropical cyclone intensity records? *Bulletin of the American Meteorological Society*, 96(4): 591-607.
- Herring, S.C., Hoerling, M.P., Kossin, J.P., Peterson, T.C., and Stott, P.A., 2015. Introduction to explaining extreme events of 2014 from a climate perspective. *Bulletin of the American Meteorological Society*, 96(12): S1-S4, S168-S169.
- Herring, S.C., Hoerling, M.P., Kossin, J.P., Peterson, T.C., and Stott, P.A., 2015. Summary and broader context. *Bulletin of the American Meteorological Society*, 96(12): S168-S172.
- Heymsfield, A.J., Bansemer, A., Poellot, M.R., and Wood, N., 2015. Observations of ice microphysics through the melting layer. *Journal of the Atmospheric Sciences*, 72(8): 2902-2928.
- Hoover, B.T., 2015. Identifying a barotropic growth mechanism in East Pacific tropical cyclogenesis using adjoint-derived sensitivity gradients. *Journal of the Atmospheric Sciences*, 72(3): 1215-1234.
- Huang, M., Mielkainen, J., Huang, B., Chen, H., Huang, H.-L.A., and Goldberg, M.D., 2015. Development of efficient GPU parallelization of WRF Yonsei University planetary boundary layer scheme. *Geoscientific Model Development*, 8(9): 2977-2990.
- Huang, M., Huang, B., Chang, Y.-L., Mielikeinen, J., Huang, H.-L.A., and Goldberg, M.D., 2015. Efficient parallel GPU design on WRF five-layer thermal diffusion scheme. *IEEE Journal of Selected Topics in*



Applied Earth Observations and Remote Sensing, 8(5): 2249-2259.

Huang, M., Huang, B., Gu, L., Huang, H.-L.A., and Goldberg, M.D., 2015. Parallel GPU architecture framework for the WRF single moment 6-class microphysics scheme. *Computers and Geosciences*, 83: 17-26.

Huang, M., Huang, B., Li, X., Huang, H.-L.A., Goldberg, M.D., and Mehta, A., 2015. Massive parallelization of the WRF GCE model toward a GPU-based end-to-end satellite data simulator unit. *IEEE Journal of Selected Topics in Applied Earth Observations and Remote Sensing*, 8(5): 2260-2272.

Jing, Z., Li, J., Schmit, T.J., and Liu, Z., 2015. The impact of AIRS atmospheric temperature and moisture profiles on hurricane forecasts: Ike (2008) and Irene (2011). *Advances in Atmospheric Sciences*, 32(3): 319-335.

Kabatas, B., Unal, A., Pierce, R.B., Kindap, T., and Pozzoli, L., 2015. The contribution of Saharan dust in PM10 concentration levels in Anatolian Peninsula of Turkey. *Science of the Total Environment*, 488-489: 413-421.

Kaplan, J., Rozoff, C.M., DeMaria, M., Sampson, C.R., Kossin, J.P., Velden, C.S., Cione, J.J., Dunion, J.P., Knaff, J.A., Zhang, J.A., Dostalek, J.F., Hawkins, J.D., Lee, T.F., and Solbrig, J.E., 2015. Evaluating environmental impacts on tropical cyclone rapid intensification predictability utilizing statistical models. *Weather and Forecasting*, 30(5): 1374-1396.

Kossin, J.P., 2015. Hurricane wind-pressure relationship and eyewall replacement cycles. *Weather and Forecasting*, 30(1): 177-181.

Kossin, J.P., 2015. Validating atmospheric reanalysis data using tropical cyclones as thermometers. *Bulletin of the American Meteorological Society*, 96(7): 1089-1096.

Kossin, J.P., Karl, T.R., Knutson, T.R., Emanuel, K.A., Kunkel, K.E., and O'Brien, J.J., 2015. Reply to "Comments on 'Monitoring and understanding trends in extreme storms: State of Knowledge'". *Bulletin of the American Meteorological Society*, 96(7): 1177-1179.

Kruk, M.C., Schreck, C.J., and Griffin, K.S., 2015. State of the climate in 2014: Remnant Eastern Pacific storms drive wacky weather across the US. *Bulletin of the American Meteorological Society*, 96(7, supplement): S108-S109.

Kummerow, C.D., Randel, D.L., Kulie, M., Wang, N.-Y., Ferraro, R., Munchak, S.J., and Petkovic, V., 2015. The evolution of the Goddard Profiling Algorithm to a fully parametric scheme. *Journal of Atmospheric and Oceanic Technology*, 32(12): 2265-2280.

Langford, A.O., Pierce, R.B., and Schultz, P.J., 2015. Stratospheric intrusions, the Santa Ana winds, and wildland fires in Southern California. *Geophysical Research Letters*, 42(14): 6091-6097.

Langford, A.O., Senff, C.J., Alvarez III, R.J., Brioude, J., Cooper, O.R., Holloway, J.S., Lin, M.Y., Marchbanks, R.D., Pierce, R.B., Sandberg, S.P., Weickmann, A.M., and Williams, E.J., 2015. An overview of the 2013 Las Vegas Ozone Study (LVOS): Impact of stratospheric intrusion and long-range transport on surface air quality. *Atmospheric Environment*, 109: 305-322.

Lattanzio, A., Fell, F., Bennartz, R., Trigo, I.F., and Schulz, J., 2015. Quality assessment and improvement of the EUMETSAT Meteosat Surface Albedo Climate Data Record. *Atmospheric Measurement Techniques*, 8(10): 4561-4571.

Lee, Y.-K., Kongoli, C., and Key, J., 2015. An in-depth evaluation of heritage algorithms for snow cover and snow depth using AMSR-E and AMSR2 measurements. *Journal of Atmospheric and Oceanic*



Technology, 32(12): 2319–2336.

Levy, R.C., Munchak, L.A., Mattoo, S., Patadia, F., Remer, L.A., and Holz, R.E., 2015. Towards a long-term global aerosol optical depth record: Applying a consistent aerosol retrieval algorithm to MODIS and VIIRS-observed reflectance. *Atmospheric Measurement Techniques*, 8(10): 4083-4110.

Li, X., Huang, B., and Zhao, K., 2015. Massively parallel GPU design of automatic target generation process in hyperspectral imagery. *IEEE Journal of Selected Topics in Applied Earth Observations and Remote Sensing*, 8(6): 2862-2869.

Liu, Y.-A., Huang, H.-L.A., Gao, W., Lim, A.H.N., Liu, C., and Shi, R., 2015. Tuning of background error statistics through sensitivity experiments and its impact on typhoon forecast. *Journal of Applied Remote Sensing*, 9(1): doi:10.1117/1.JRS.9.096051.

Liu, Y., 2015. Estimating errors in cloud amount and cloud optical thickness due to limited spatial sampling using a satellite imager as a proxy for nadir-view sensors. *Journal of Geophysical Research-Atmospheres*, 120(14): 6980-6991.

Lui, Y., Key, J., Tschudi, M., Dworak, R., Mahoney, R., and Baldwin, D., 2015. Validation of the Suomi NPP VIIRS ice surface temperature environmental data record. *Remote Sensing*, 7(12): 17258-17271.

Ma, Y., Wu, H., Wang, L., Huang, B., Ranjan, R., Zomaya, A., and Jie Wei, 2015. Remote sensing big data computing: Challenges and opportunities. *Future Generation Computer Systems*, 51: 47-60.

Manion, A., Evans, C., Olander, T.L., Velden, C.S., and Grasso, L.D., 2015. An evaluation of advanced Dvorak Technique-derived tropical cyclone intensity estimates during extratropical transition using synthetic satellite imagery. *Weather and Forecasting*, 30(4): 984–1009.

Merrelli, A., Bennartz, R., O'Dell, C.W., and Taylor, T.E., 2015. Estimating bias in the OCO-2 retrieval algorithm caused by 3-D radiation scattering from unresolved boundary layer clouds. *Atmospheric Measurement Techniques*, 8(4): 1641-1656.

Mielikainen, J., Huang, B., and Huang, H.-L.A., 2015. Optimizing Total Energy-Mass Flux (TEMF) planetary boundary layer scheme for Intel's Many Integrated Core (MIC) architecture. *IEEE Journal of Selected Topics in Applied Earth Observations and Remote Sensing*, 8(8): 4196-4199.

Mielikainen, J., Huang, B., Huang, H.-L.A., and Lee, T., 2015. Performance and scalability of the JCSDA Community Radiative Transfer Model (CRTM) on NVIDIA GPUs. *IEEE Journal of Selected Topics in Applied Earth Observations and Remote Sensing*, 8(4): 1519-1527.

Miller, S.D., Straka, W.C.I., Yue, J., Smith, S.M., Alexander, M.J., Hoffmann, L., Setvak, M., and Partain, P.T., 2015. Upper atmospheric gravity wave details revealed in nightglow satellite imagery. *Proceedings of the National Academy of Sciences (PNAS)*, 112(49): E6728–E6735.

Norin, L., Devasthale, A., L'Ecuyer, T.S., Wood, N.B., and Smalley, M., 2015. Intercomparison of snowfall estimates derived from the CloudSat Cloud Profiling Radar and the ground-based weather radar network over Sweden. *Atmospheric Measurement Techniques*, 8(12): 5009-5021.

Otkin, J.A., Anderson, M.C., Hain, C., and Svoboda, m., 2015. Using Temporal Changes in Drought Indices to Generate Probabilistic Drought Intensification Forecasts. *Journal of Hydrometeorology*, 16(1): 88–105.

Otkin, J.A., Shafer, M., Svoboda, M., Wardlow, B., Anderson, M.C., Hain, C., and Basara, J., 2015. Facilitating the use of drought early warning information through interactions with agricultural stakeholders. *Bulletin of the American Meteorological Society*, 96(7): 1073–1078.



Pavlonis, M.J., Sieglaff, J., and Cintineo, J., 2015. Spectrally Enhanced Cloud Objects - A generalized framework for automated detection of volcanic ash and dust clouds using passive satellite measurements: 2. Cloud object analysis and global application. *Journal of Geophysical Research-Atmospheres*, 120(15): 7842-7870.

Pavlonis, M.J., Sieglaff, J., and Cintineo, J., 2015. Spectrally Enhanced Cloud Objects - A generalized framework for automated detection of volcanic ash and dust clouds using passive satellite measurements: 1. Multispectral analysis. *Journal of Geophysical Research-Atmospheres*, 120(15): 7813-7841.

Posselt, D.J., Li, X., Tushaus, S.A., and Mecikalski, J.R., 2015. Assimilation of dual-polarization radar observations in mixed- and ice-phase regions of convective storms: Information content and forward model errors. *Monthly Weather Review*, 143(7): 2611–2636.

Rathore, M.M.U., Paul, A., Ahmed, A., Chen, B.-W., Huang, B., and Ji, W., 2015. Real-time big data analytical architecture for remote sensing application. *IEEE Journal of Selected Topics in Applied Earth Observations and Remote Sensing*, 8(10): 4610-4621.

Reid, J.S., Lagrosas, N.D., Jonsson, H.H., Reid, E.A., Sessions, W.R., Simpas, J.B., Uy, S.N., Boyd, T.J., Atwood, S.A., Blake, D.R., Campbell, J.R., Cliff, S.S., Holben, B.N., Holz, R.E., Hyer, E.J., Lynch, P., Meinardi, S., Posselt, D.J., Richardson, K.A., Salinas, S.V., Smirnov, A., Wang, Q., Yu, L., and Zhang, J., 2015. Observations of the temporal variability in aerosol properties and their relationships to meteorology in the summer monsoonal South China Sea/East Sea: the scale-dependent role of monsoonal flows, the Madden-Julian Oscillation, tropical cyclones, squall lines and cold pools. *Atmospheric Chemistry and Physics*, 15(4): 1745-1768.

Roebbing, R., Baum, B., Bennartz, R., Hamann, U., Heidinger, A., Meirink, J.F., Stengle, M., Thoss, A., Walther, A., and Watts, P., 2015. Summary of the fourth Cloud Retrieval Evaluation Workshop. *Bulletin of the American Meteorological Society*, 96(4): ES71–ES74.

Roman, J., Knuteson, R., Ackerman, S., and Revercomb, H., 2015. Predicted changes in the frequency of extreme precipitable water vapor events. *Journal of Climate*, 28(18): 7057–7070.

Rozoff, C.M., Velden, C.S., Kaplan, J., Kossin, J.P., and Wimmers, A.J., 2015. Improvements in the probabilistic prediction of tropical cyclone rapid intensification with passive microwave observations. *Weather and Forecasting*, 30(4): 1016-1038.

Saide, P.E., Spak, S.N., Pierce, R.B., Otkin, J.A., Schaack, T.K., Heidinger, A.K., da Silva, A.M., Kacenenbogen, M., Redemann, J., and Carmichael, G.R., 2015. Central American biomass burning smoke can increase tornado severity in the U.S. *Geophysical Research Letters*, 42(3): 956-965.

Schmetz, J. and Menzel, W.P., 2015. A look at the evolution of meteorological satellites: Advancing capabilities and meeting user requirements. *Weather, Climate, and Society*, 7(4): 309–320.

Schmit, T.J., Goodman, S.J., Gunshor, M.M., Sieglaff, J., Heidinger, A.K., Bachmeier, A.S., Lindstrom, S.S., Terborg, A., Feltz, J., Bah, K., Rudlosky, S., Lindsey, D.T., Rabin, R.M., and Schmidt, C.C., 2015. Rapid refresh information of significant events: Preparing users for the next generation of geostationary operational satellites. *Bulletin of the American Meteorological Society*, 96(4): 561–576, supplement.

Shapiro, A., Rahimi, S., Rotvin, C.K., and Orf, L., 2015. On the use of advection correction in trajectory calculations. *Journal of the Atmospheric Sciences*, 72(11): 4261–4280.

Smith, N., Smith, W.L.Sr., Weisz, E., and Revercomb, H.E., 2015. AIRS, IASI, and CrIS retrieval records at climate scales: An investigation into the propagation of systematic uncertainty. *Journal of Applied Meteorology and Climatology*, 54(7): 1465-1481.



- Stengel, M., Mieruch, S., Jerg, M., Karlsson, C.-G., Scheirer, R., Maddux, B., Meirink, J.F., Poulsen, C., Siddans, R., Walther, A., and Hollman, R., 2015. The Cloud Climate Change Initiative: Assessment of state-of-the-art cloud property retrieval schemes applied to AVHRR heritage measurements. *Remote Sensing of Environment*, 162: 363-379.
- Straka, W.C.I., Seaman, C.J., Baugh, K., Cole, K., Stevens, E., and Miller, S.D., 2015. Utilization of the Suomi National Polar-Orbiting Partnership (NPP) Visible Infrared Imaging Radiometer Suite (VIIRS) day/night band for Arctic ship tracking and fisheries management. *Remote Sensing*, 7(1): 971-989.
- Sullivan, J.T., McGee, T.J., Thompson, A.M., Pierce, R.B., Sunnicht, G.K., Twigg, L.W., Eloranta, E., and Hoff, R.M., 2015. Characterizing the lifetime and occurrence of stratospheric-tropospheric exchange events in the rocky mountain region using high-resolution ozone measurements. *Journal of Geophysical Research-Atmospheres*, 120(24): 12410–12424.
- Sun, B., Free, M., You, H.L., Foster, M.J., Heidinger, A., and Karlsson, K.-G., 2015. Variability and trends in US cloud cover: ISCCP, PATMOS-x, and CLARA-A1 compared to homogeneity-adjusted weather observations. *Journal of Climate*, 28(11): 4373–4389.
- Volkamer, R., Baidar, S., Campos, T.L., Coburn, S., DiGangi, J.P., Dix, B., Eloranta, E.W., Koenig, T.K., Morley, B., Ortega, I., Pierce, B.R., Reeves, M., Sinreich, R., Wang, S., Zondlo, M.A., and Romanshkin, P.A., 2015. Aircraft measurements of BrO, IO, glyoxal, NO<sub>2</sub>, H<sub>2</sub>O, O<sub>2</sub>-O<sub>2</sub> and aerosol extinction profiles in the tropics: Comparison with aircraft-/ship-based in situ and lidar measurements. *Atmospheric Measurement Techniques*, 8(5): 2121-2148, supplement.
- Volkamer, R., Baidar, S., Campos, T.L., Coburn, S., DiGangi, J.P., Dix, B., Eloranta, E.W., Koenig, T.K., Morley, B., Ortega, I., Pierce, B.R., Reeves, M., Sinreich, R., Wang, S., Zondlo, M.A., and Romanshkin, P.A., 2015. Supplement to: Aircraft measurements of BrO, IO, glyoxal, NO<sub>2</sub>, H<sub>2</sub>O, O<sub>2</sub>-O<sub>2</sub> and aerosol extinction profiles in the tropics: Comparison with aircraft-/ship-based in situ and lidar measurements. *Atmospheric Measurement Techniques*, 8(5): 2121-2148, supplement.
- Walsh, K.J.E., Camargo, S.J., Vechhi, G.A., Daloz, A.S., Elsner, J., Emanuel, K., Horn, M., Lim, Y.-K., Roberts, M., Patricola, C., Scoccimarro, E., Sobel, A.H., Strazzo, S., Villarini, G., Wehner, M., Zhao, M., Kossin, J.P., LaRow, T., Oouchi, K., Schubert, S., Wang, H., Bachmeister, J., Chang, P., Chauvin, F., Jablonowski, C., Kumar, A., Murakami, K., Ose, T., Reed, K.A., Saravanan, R., Yamada, Y., Zarzycki, C.M., Vidale, P.L., Honas, J.A., and Henderson, N., 2015. Hurricanes and climate: The US CLIVAR Working Group on Hurricanes. *Bulletin of the American Meteorological Society*, 96(6): 997–1017.
- Wang, K., Yahya, K., Zhang, Y., Hogrefe, C., Pouliot, G., Knote, C., Hodzic, A., San Jose, R., Perez, J.L., Jimenez-Guerrero, P., Baro, R., Makar, P., and Bennartz, R., 2015. A multi-model assessment for the 2006 and 2010 simulations under the Air Quality Model Evaluation International Initiative (AQMEII) Phase 2 over North America: Part II. Evaluation of column variable predictions using satellite data. *Atmospheric Environment*, 115: 587-603.
- Wang, P., Li, J., Goldberg, M.D., Schmit, T.J., Lim, A.H.N., Li, Z., Han, H., Li, J., and Ackerman, S.A., 2015. Assimilation of thermodynamic information from advanced infrared sounders under partially cloudy skies from regional NWP. *Journal of Geophysical Research-Atmospheres*, 120(16): 5469-5484.
- Wang, S., Schmidt, J.A., Baidar, S., Coburn, S., Dix, B., Koenig, T.K., Apel, E., Bowdalo, D., Campos, T.L., Eloranta, E., Evans, M.J., DiGangi, J.P., Zondlo, M.A., Gao, R.-S., Haggerty, J.A., Hall, S.R., Hornbrook, R.S., Jacob, D., Morley, B., Pierce, B., Reeves, M., Romashkin, P., ter Schure, A., and Volkamer, R., 2015. Active and widespread halogen chemistry in the tropical and subtropical free troposphere. *Proceedings of the national Academy of Sciences of the United States of America*, 112(30): 9281-9286.
- Weisz, E., Smith, N., and Smith, W.L.Sr., 2015. The use of hyperspectral sounding information to monitor



atmospheric tendencies leading to severe local storms. *Earth and Space Science*, 2(9): 369–377.

Wood, N.B., L'Ecuyer, T.S., Heymsfield, A.J., and Stephens, G.L., 2015. Microphysical constraints on millimeter-wavelength scattering properties of snow particles. *Journal of Applied Meteorology and Climatology*, 54(4): 909–931.

Wu, J., Kong, W., Mielikainen, J., and Huang, B., 2015. Lossless compression of hyperspectral imagery via clustered differential pulse code modulation with removal of local spectral outliers. *IEEE Signal Processing Letters*, 23(12): 2194-2198.

Wu, T.-C., Velden, C.S., Majumdar, S.J., Liu, H., and Anderson, J.L., 2015. Understanding the influence of assimilating subsets of enhanced atmospheric motion vectors on numerical analyses and forecasts of tropical cyclone track and intensity with an ensemble Kalman filter. *Monthly Weather Review*, 143(7): 2506–2531 .

Xu, J., Li, Q., Yue, J., Hoffmann, L., Straka, W.C.I., Wang, C., Liu, M., Yuan, W., Han, S., Miller, S.D., Sun, L., Liu, X., Liu, W., Yang, J., and Ning, B., 2015. Concentric gravity waves over northern China observed by an airglow imager network and satellites. *Journal of Geophysical Research-Atmospheres*, 120(21): 11058-11078.

Yan, J., Wang, L., Chen, L., Zhao, L., and Huang, B., 2015. A dynamic remote sensing data-driven approach for oil spill simulation in the sea. *Remote Sensing*, 7(6): 7105-7125.

Yang, P., Liou, K.-N., Bi, L., Liu, C., Yi, B., and Baum, B.A., 2015. On the radiative properties of ice clouds: Light scattering, remote sensing, and radiation parameterization. *Advances in Atmospheric Sciences*, 32(1): 32-63.

Yao, Z., Li, J., and Zhao, Z., 2015. Synergistic use of AIRS and MODIS for dust top height retrieval over land. *Advances in Atmospheric Sciences*, 32: 470-476.

Yates, E.L., Iraci, L.T., Austerberry, D., Pierce, R.B., Roby, M.C., Tadic, J.M., Loewenstein, M., and Gore, W., 2015. Characterizing the impacts of vertical transport and photochemical ozone production on an exceedance area. *Atmospheric Environment*, 109: 342-350.